

# Linear guideways

## HG/QH series

### 3.1.9 Dimensions of the HG/QH blocks

#### 3.1.9.1 HGH/QHH

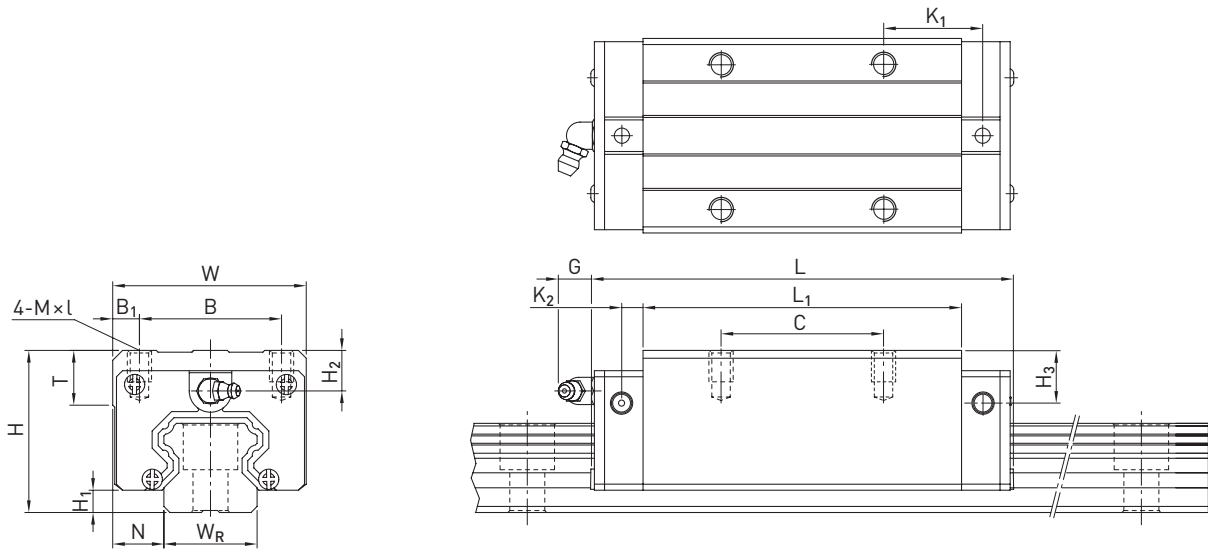

Table 3.6 Dimensions of the block

Series/size	Installation dimensions [mm]			Dimensions of the block [mm]													Load ratings [N]		Weight [kg]
	H	H <sub>1</sub>	N	W	B	B <sub>1</sub>	C	L <sub>1</sub>	L	K <sub>1</sub>	K <sub>2</sub>	G	M × l	T	H <sub>2</sub>	H <sub>3</sub>	C <sub>dyn</sub>	C <sub>0</sub>	
HGH15CA	28	4.3	9.5	34	26	4.0	26	39.4	61.4	10.00	4.85	5.3	M4 × 5	6.0	7.95	7.7	14,700	23,470	0.18
QHH15CA	28	4.0	9.5	34	26	4.0	26	39.4	61.4	10.00	5.00	5.3	M4 × 5	6.0	7.95	8.2	17,940	19,860	0.18
HGH20CA	30	4.6	12.0	44	32	6.0	36	50.5	77.5	12.25	6.00	12.0	M5 × 6	8.0	6.00	6.0	27,100	36,680	0.30
HGH20HA							50	65.2	92.2	12.60							32,700	47,960	0.39
QHH20CA	30	4.6	12.0	44	32	6.0	36	50.5	76.7	11.75	6.00	12.0	M5 × 6	8.0	6.00	6.0	30,000	33,860	0.29
QHH20HA							50	65.2	91.4	12.10							35,700	42,310	0.38
HGH25CA	40	5.5	12.5	48	35	6.5	35	58.0	84.0	15.70	6.00	12.0	M6 × 8	8.0	10.00	9.0	34,900	52,820	0.51
HGH25HA							50	78.6	104.6	18.50							42,200	69,070	0.69
QHH25CA	40	5.5	12.5	48	35	6.5	35	58.0	83.4	15.70	6.00	12.0	M6 × 8	8.0	10.00	9.0	41,900	48,750	0.50
QHH25HA							50	78.6	104.0	18.50							50,610	60,940	0.68
HGH30CA	45	6.0	16.0	60	40	10.0	40	70.0	97.4 <sup>1)</sup>	20.25	6.00	12.0	M8 × 10	8.5	9.50	13.8	48,500	71,870	0.88
HGH30HA							60	93.0	120.4 <sup>2)</sup>	21.75							58,600	93,990	1.16
QHH30CA	45	6.0	16.0	60	40	10.0	40	70.0	97.4	19.50	6.25	12.0	M8 × 10	8.5	9.50	9.0	58,260	66,340	0.87
QHH30HA							60	93.0	120.4	21.75							70,320	88,450	1.15
HGH35CA	55	7.5	18.0	70	50	10.0	50	80.0	112.4	20.60	7.00	12.0	M8 × 12	10.2	16.00	19.6	64,600	93,990	1.45
HGH35HA							72	105.8	138.2	22.50							77,900	122,770	1.92
QHH35CA	55	7.5	18.0	70	50	10.0	50	80.0	113.6	19.00	7.50	12.0	M8 × 12	10.2	15.50	13.5	78,890	86,660	1.44
QHH35HA							72	105.8	139.4	20.90							95,230	115,550	1.90
HGH45CA	70	9.5	20.5	86	60	13.0	60	97.0	139.4	23.00	10.00	12.9	M10 × 17	16.0	18.50	30.5	103,800	146,710	2.73
HGH45HA							80	128.8	171.2	28.90							125,300	191,850	3.61
QHH45CA	70	9.2	20.5	86	60	13.0	60	97.0	139.4	23.00	10.00	12.9	M10 × 17	16.0	18.50	20.0	119,400	135,420	2.72
QHH45HA							80	128.8	171.2	29.09							144,130	180,560	3.59
HGH55CA	80	13.0	23.5	100	75	12.5	75	117.7	166.7	27.35	11.00	12.9	M12 × 18	17.5	22.00	29.0	153,200	211,230	4.17
HGH55HA							95	155.8	204.8	36.40							184,900	276,230	5.49
HGH65CA	90	15.0	31.5	126	76	25.0	70	144.2	200.2	43.10	14.00	12.9	M16 × 20	25.0	15.00	15.0	213,200	287,480	7.00
HGH65HA							120	203.6	259.6	47.80							277,800	420,170	9.82

<sup>1)</sup> 98.8 for type SE

<sup>2)</sup> 121.8 for type SE

For dimensions of the rail, see Page 41, for standard as well as optional lubrication adapter, see Page 150.