

BH LINE

ED. 17
UPD. 05



Alusic

ALUMINIO PROFILIAI IR PRIEDAI

PROFILI IN ALLUMINIO E PERFILES DE
ALUMINIO Y ACCESORIOS PROFILÉS ET
ACCESSOIRES EN ALUMINIUM
ALUMINIUM PROFILE UND ZUBEHÖR

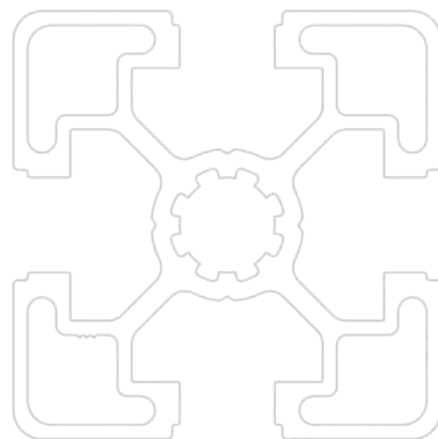

BH LINE



















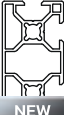
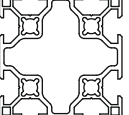

Alusic

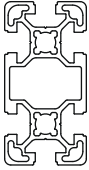
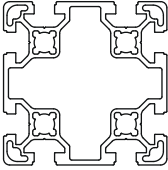





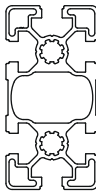
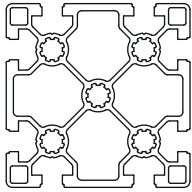
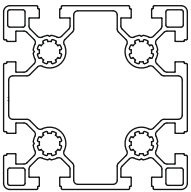
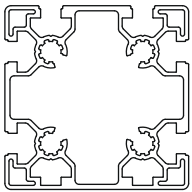
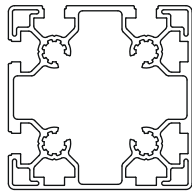
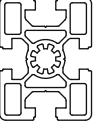
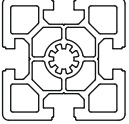
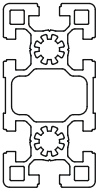
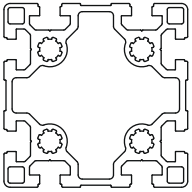
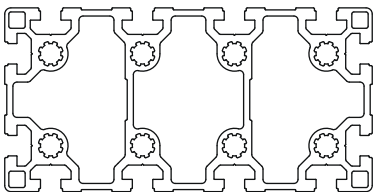

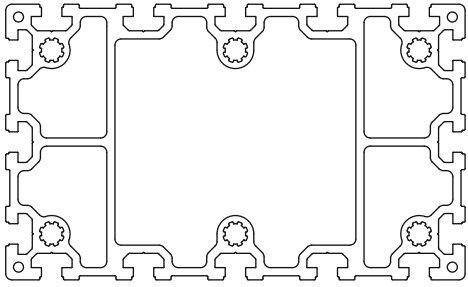
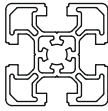
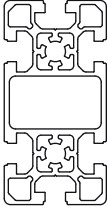
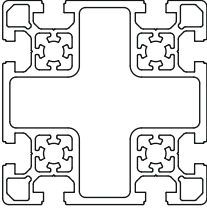

ALUMINIO PROFILIAI IR PRIEDAI

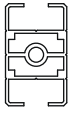
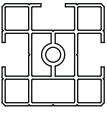
PROFILI IN ALLUMINIO E PRIEDAI
PERFILES DE ALUMINIO Y ACCESORIOS
PROFILÉS ET ACCESSOIRES EN ALUMINIUM
ALUMINIUM PROFILE UND ZUBEHÖR

PROFILES / PROFILIAI / PERFILES / PROFILÉS / PROFILE

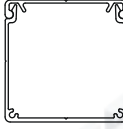
<p>BH 6 20</p>	 084.111.001 psl.17  084.111.004 psl.17  084.111.002 psl.18
<p>BH 8 30</p>	 084.107.002 psl.23  084.107.006 psl.23  084.107.005 psl.25  NEW 084.107.008 psl.24  NEW 084.107.009 psl.25  084.107.003 psl.26  NEW 084.107.010 psl.26  084.107.004 psl.27  NEW 084.107.007 psl.28
<p>BH 8 30</p>	 NEW 084.107.011 psl.23  NEW 084.107.012 psl.26
<p>BH 10 40</p>	 084.113.001 psl.33  084.113.002 psl.33  084.113.003 psl.34
<p>BH L 10 45</p>	 084.105.004 psl.39  084.105.015 psl.40  084.105.010 psl.39  084.105.011 psl.40  084.105.012 psl.41  084.105.018 psl.41
<p>BH L 10 45</p>	 084.105.006 psl.42  084.105.009 psl.45  084.105.005 psl.44  084.105.017 psl.46  084.105.016 psl.45
<p>BH H 10 45</p>	 084.105.007 psl.42  084.105.008 psl.43  084.105.019 psl.43  084.105.014 psl.44  084.105.013 psl.46

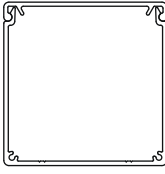
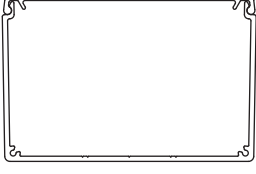
PROFILES / PROFILIAI / PERFILES / PROFILÉS / PROFILE

<p>BH H 10 45</p>	 <p>084.105.020 psl.47</p>								
<p>BH 10 50</p>	 <p>084.109.001 psl.51</p>		 <p>084.109.002 psl.51</p>		 <p>084.109.003 psl.52</p>				
<p>APTVARAI fenestras Cristales Claytons Umzammangen</p>	 <p>084.104.003 psl.57</p>	 <p>084.112.001 psl.57</p>	 <p>084.112.002 psl.58</p>						
<p>Canaline Canaletois Canalones Kanalstange</p>	 <p>084.101.092 084.101.093 psl.61</p>	 <p>084.101.097 084.101.098 psl.61</p>	 <p>084.101.053 084.101.054 psl.62</p>	 <p>084.101.078 084.101.076 psl.63</p>	 <p>084.101.101 084.101.056 psl.63</p>	 <p>084.101.102 084.101.098 psl.62</p>	 <p>084.101.055 084.101.056 psl.64</p>	 <p>084.101.099 084.101.100 psl.64</p>	
 <p>084.101.104 084.101.105 psl.65</p>									

ACCESSORIES / **PIEDAI** / ACCESORIOS / ACCESSOIRES / ZUBEHÖR

PROFILIO DANGTELIAI / CHIUDICAVA / PERFILES DE RECUBRIMIENTO / PROFILÉS DE FERMETURE / ABDECKPROFILE

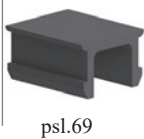

SCREWS / VARŽTAI / TORNILLOS / VIS / SCHRAUBEN

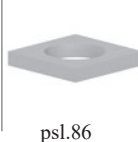

CONNECTORS / JUNGTYS / JUNTAS / ÉLÉMENTS DE LIAISON / BEFESTIGUNGSELEMENTE

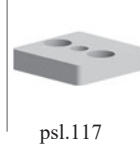
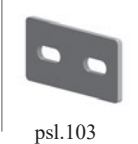
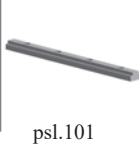

ANGLES / KAM PAI / ANGULARES / EQUERRES DE FIXACION / WINKEL



FEET / KOJOS / PIES / PIEDS / STELLFÜSSE



TELESCOPIC COLUMNS / TELESKOPINĖS KOLONOS / COLUMNAS TELESCÓPICAS / COLONNES TÉLESCOPIQUES / TELESKOPISCHE SÄULEN



CASTORS / RATUKAI / RUEDAS / ROULETTES / ROLLEN



PANELS / PLOKŠTĖS / PANELES / PANNEAUX / PLATTEN

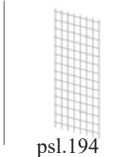
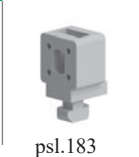
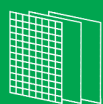

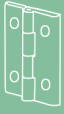
ACCESSORIES / **PRIEDAI** / ACCESORIOS / ACCESSOIRES / ZUBEHÖRHINGES / **VYRIAI** / BISAGRAS / CHARNIÈRES / SCHARNIERE

psl.195



psl.205



psl.207

RANKENAS / **RANKENOS** / MANIJAS / POIGNÉES / GRIFFE

psl.212



psl.215

ACCESSORIES FOR DOORS / **PRIEDAI DURIMS** / PER SPORTELLI / ACCESORIOS PARA PUERTAS / ACCESSOIRES POUR PORTES / ZUBEHÖR FÜR TÖRE

psl.222



psl.234



psl.237

LED LIGHTING DEVICES / **SISTEMOS LED** / SISTEMAS DE ILUMINACIÓN POR LED / AP PAREILS D'ÉCLAIRAGE À LED / LED-LEISTEN

psl.243



psl.226

TOOLS / **ĮRANKIAI** / HERRAMIENTAS / OUTILS / WERKZEUGE

psl.248

ASSEMBLY SYSTEMS / **SURINKIMO SISTEMOS** / SISTEMAS DE MONTAJE / SISTÈMES DE MONTAGE / MONTAGESYSTEME

psl.254

LT

„Alusic“ – tai didžiulis ekstruzinio aliuminio profilių priedų asortimentas. Įmonė naudoja pažangiausias technologijas tiek 2D/3D modeliavimui, tiek greitam prototipų kūrimui naudojant FDM (lydyto nusodinimo modeliavimą). Nuolatinis įmonės produktų asortimento plėtimas reiškia, kad mūsų kataloge yra komponentų, pagamintų naudojant įvairias technologijas. Mūsų svetainė www.alusic.com atnaujinama kasdien, kad mūsų klientai būtų informuoti apie visas naujienas ir inovacijas. „Alusic“ turi ISO 9001:2008 ir EN1090 sertifikatus: šie griežti sertifikatai liudija apie mūsų nuolatinį įsipareigojimą užtikrinti savo klientams aukščiausius kokybės standartus.

IT

Alusic significa una vasta gamma di accessori per profili in alluminio estruso. L'azienda si avvale di software all'avanguardia sia per quanto riguarda la modellazione 2D/3D che per la prototipazione rapida con tecnologia FDM (Fused Deposition Modeling).

Il continuo ampliamento della gamma di prodotti fa sì che all'interno del catalogo vi siano i componenti realizzati attraverso le più disparate tecnologie. Al fine di mantenere il cliente sempre informato sulle novità il sito www.alusic.com viene aggiornato quotidianamente.

Alusic inoltre dispone della certificazione ISO9001:2008 e della severa EN1090 a testimonianza del continuo impegno per garantire ai suoi clienti un elevato standard di qualità.

ES

Alusic ofrece una extensa gama de accesorios para perfiles de aluminio extruido. La empresa utiliza softwares de vanguardia tanto para el modelado 2D/3D como para la creación rápida de prototipos con tecnología FDM (Fused Deposition Modeling).

La continua ampliación de la gama de productos hace que en el catálogo puedan encontrarse componentes fabricados con las más diversas tecnologías. Para mantener a los clientes siempre informados acerca de las novedades, la página Web www.alusic.com se actualiza diariamente.

Además, Alusic dispone de la certificación ISO 9001:2008 y de la estricta EN 1090, lo que demuestra el continuo esfuerzo para garantizar a sus clientes un elevado estándar de calidad.

FR

Alusic est synonyme de vaste gamme d'accessoires pour profilés en aluminium extrudé. L'entreprise dispose d'un logiciel d'avant-garde utilisé pour la modélisation 2D/3D et pour la réalisation rapide de prototypes à l'aide de la technologie FDM (Fused Deposition Modeling).

La constante extension de la gamme de produits est telle que le catalogue contient des composants réalisés en recourant aux technologies les plus diverses. Pour que le client soit toujours informé des nouveautés, le site www.alusic.com est quotidiennement actualisé.

De plus, Alusic dispose de la certification ISO 9001:2008 et respecte la très sévère norme EN 1090, attestant ainsi les constants efforts déployés afin de garantir aux clients de hauts standards de qualité.

DE

Alusic bietet eine große Auswahl an Zubehör für stranggepresste Aluminiumprofile. Das Unternehmen nutzt hochmoderne Software – sowohl für die 2D-/3DModellierung als auch für das Rapid Prototyping mit FDM-Technologie (Fused Deposition Modeling).

Dank der kontinuierlichen Erweiterung der Produktpalette finden sich im Katalog Komponenten, die durch unterschiedlichste Technologien geschaffen werden. Damit der Kunde stets über alle Neuigkeiten informiert ist, wird die Website www.alusic.com täglich aktualisiert.

Des Weiteren verfügt Alusic über eine Zertifizierung nach ISO 9001:2008 und nach der strengen EN 1090 – Zeugnis des stetigen Einsatzes des Unternehmens, um seinen Kunden einen hohen Qualitätsstandard zu garantieren.



PROFILŲ TVIRTINIMAS

FISSAGGIO DEI PROFILI / FIJACIÓN DE LOS PERFILES / FIXATION DES PROFILÉS / BEFESTIGUNG DER PROFILE

The choice of fasteners for the various profiles is very important, and there are numerous different types:

Tvirtinimo elementų pasirinkimas įvairiems profiliams yra labai svarbus, ir jų yra daug įvairių tipų:

La elección de la fijación entre los distintos perfiles es muy importante y existen diferentes tipos:

Le choix des fixations entre les différents profilés revêt une grande importance; il en existe de différents types:

Die Wahl der Befestigungsart zwischen den unterschiedlichen Profilen ist äußerst wichtig und es gibt verschiedene Möglichkeiten:

1

Fastening with screw in slot. Quick, simple installation.

Tvirtinimas varžtais. Greitas ir paprastas montavimas.

Fijación con tornillo en la ranura. Instalación sencilla y rápida.

Fixation à vis dans la rainure. Installation simple et rapide.

Befestigung mit Schraube in Nut. Einfache und schnelle Installation.

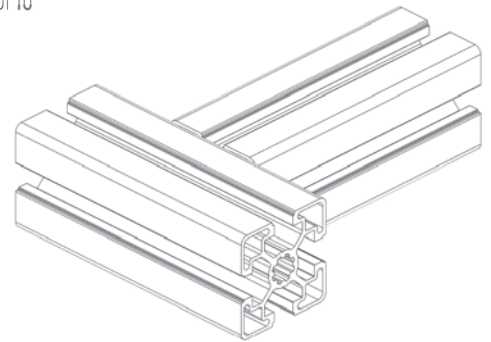
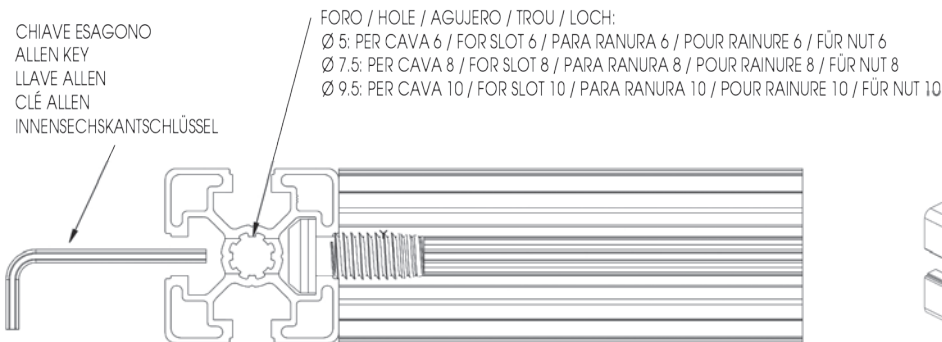

2

Fastening with through screw or counterbore.

Secure and simple, this solution ensures that parts will not slip if the screws come loose.

Tvirtinimas kiauryminiu varžtu arba įgilintu grioveliu.

Saugus ir paprastas sprendimas užtikrina, kad dalys neslystų, jei varžtai atsilaisvintų montavimo metu.

Fijación con tornillo pasante o avellanado.

Sencillo y seguro, garantiza que los componentes no se desacoplen en caso de aflojamiento de los tornillos. Fixation à vis traversante ou lamage.

Simple et sûre, cette fixation prévient le déboîtement des pièces en cas de desserrage des vis. Befestigung mit Durchsteckschraube oder Senkung.

Einfach und sicher, garantiert die Sicherung der Teile im Falle eines Lösens der Schrauben.

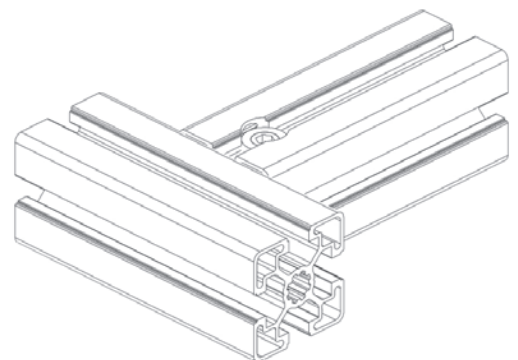
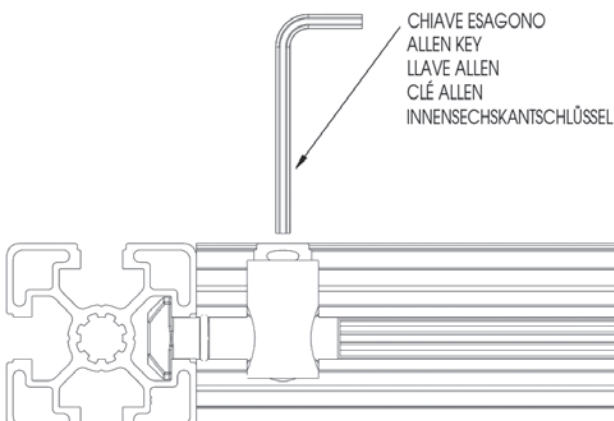

3

Fastening with angles or connectors. Wide possibility for adjustment and ease of installation.
 Tvirtinimas kampuotais arba jungtimis. Plačios reguliavimo galimybės ir paprastas montavimas.
 Fijación con escuadras o acopladores. Gran posibilidad de ajuste y facilidad de montaje.
 Fixation à cornières ou connecteurs. Grande possibilité de réglage et facilité de montage.
 Befestigung mit Winkelverbindern oder Verbindungsstücken. Zahlreiche Einstellmöglichkeiten und einfache Montage.

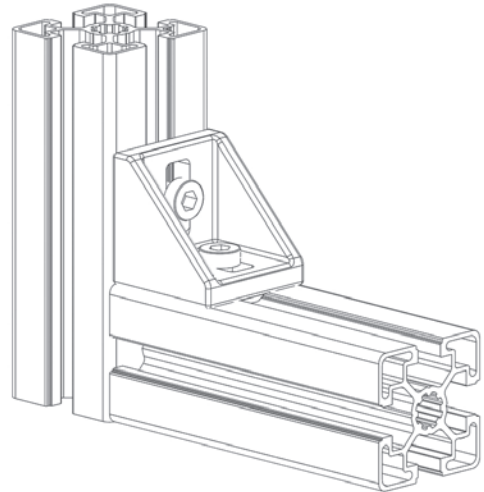
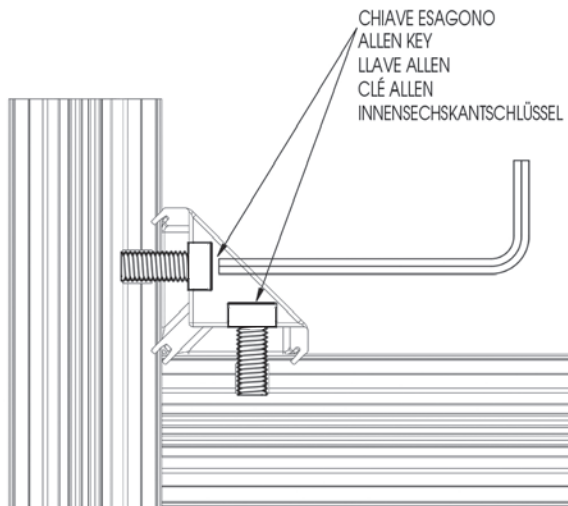

THREADING OF PROFILES

PROFILIJŲ SRIEGIMAS / ROSCADO DE LOS PERFILES / FILETAGE DES PROFILÉS / GEWINDE DER PROFILE

When making the threads, we recommend that you follow the depths (L [mm]) given in the following table:

Sriegiant sriegius, rekomenduojame laikytis šioje lentelėje pateiktų gylių (L [mm]):

A la hora de realizar los roscados, se aconseja respetar las profundidades (L [mm]) indicadas en la siguiente tabla:

Pour la réalisation des filetages, il est recommandé de respecter les profondeurs (L (mm)) indiquées dans le tableau ci-après: Bei der Ausführung der Gewinde sollten die in der folgenden Tabelle angegebenen Tiefen (L [mm]) eingehalten werden:

Slot / Griovelis / Ranura / Rainure / veržlė	M	L (mm)
6	6	15
8	8	25
10	12	30

The maximum screw tightening torque (C MAX) suggested for the assembly of Alusic components (unless otherwise specified or particular applications to be assessed on a case-by-case basis) is as follows:

Didžiausias varžtų priveržimo sukimo momentas (C MAX), rekomenduojamas „Alusic“ komponentų surinkimui (nebent nurodyta kitaip arba konkretus pritaikymas būtų vertinamas kiekvienu atveju atskirai), yra toks:

Los pares de apriete máximos (C MAX) recomendados para los tornillos destinados al montaje de los distintos componentes del catálogo Alusic (salvo que se especifique otra cosa o para aplicaciones especiales, que deben evaluarse caso por caso) son los siguientes:

Les couples de serrage maximal des vis (C MAX) recommandés pour les vis des différents composants du catalogue Alusic (sauf indication contraire ou applications particulières à évaluer au cas par cas) sont les suivants:

Die maximalen Anzugsmomente (C MAX), die für die Schrauben für die verschiedenen Komponenten des Alusic-Katalogs empfohlen werden (sofern nicht anders angegeben oder bei besonderen Anwendungen, die für den jeweiligen Fall zu bewerten sind), sind folgende:

Slot / Griovelis / Ranura / Rainure / veržlė	M	C MAX (N/m)
6	6	10
8	8	20
10	12	35

LOAD/BENDING DIAGRAM

APKROVOS / LENKIMO DIAGRAMA/ INFLESSIONE / DIAGRAMA CARGA/INFLEXIÓN / DIAGRAMME CHARGE/FLEXION / LAST-/BIEGEDIAGRAMM

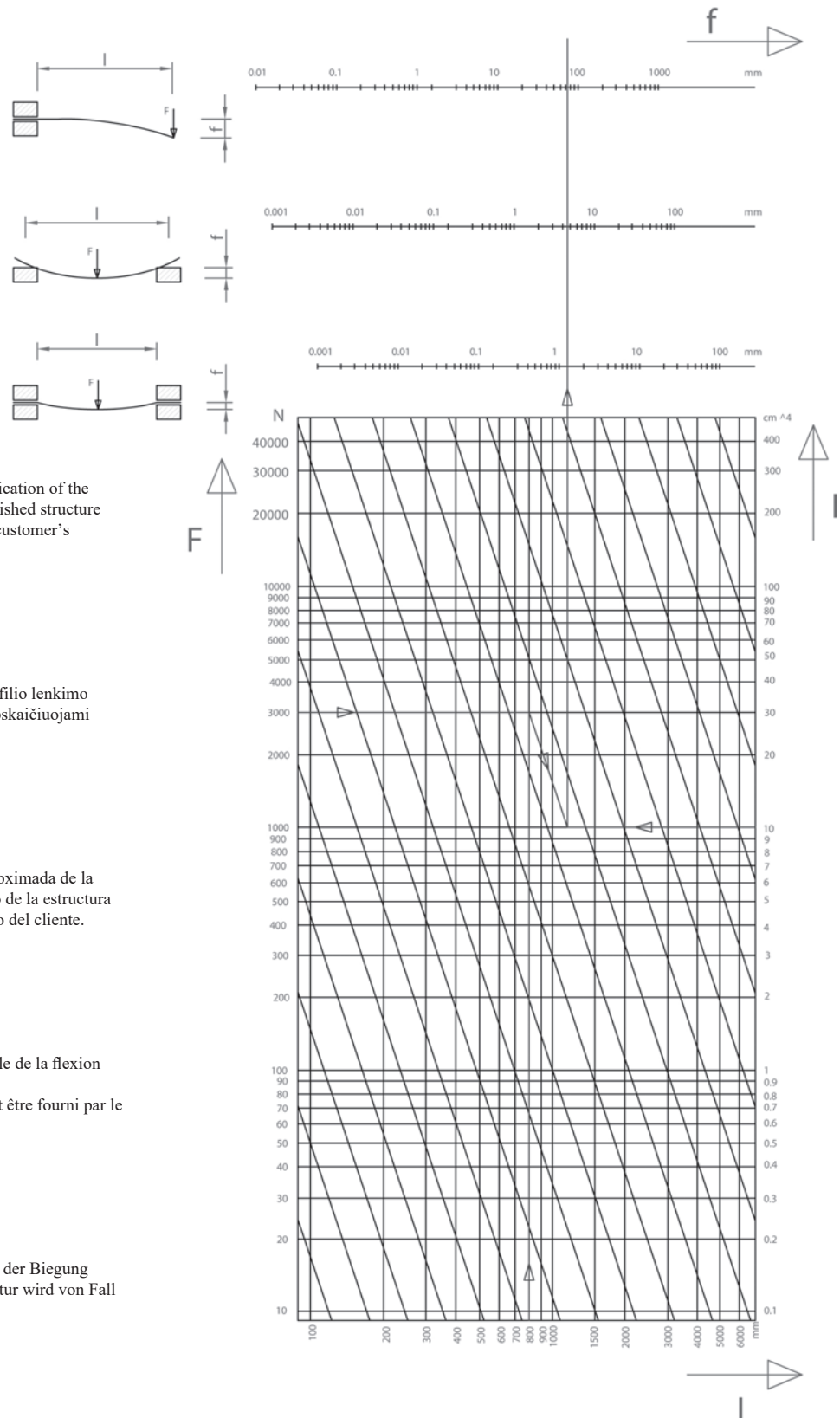

The diagram shown to the side provides a general indication of the bending of an aluminium profile. The sizing of the finished structure will be calculated on a case-by-case basis, and is the customer's responsibility.

Example:

Load: 3000 N

Moment of inertia: 10 cm⁴

Distance between supports: 800 mm

Šone pateikta diagrama pateikia bendrą aliuminio profilio lenkimo apibūdinimą. Gatavos konstrukcijos matmenys bus apskaičiuojami kiekvienu atveju atskirai ir yra kliento atsakomybė.

Pavyzdys:

Apkrova: 3000 Ne

Inercijos momentas: 10 cm⁴

Atstumas tarp atramų: 800 mm

El diagrama contiguo proporciona una indicación aproximada de la flexión de un perfil de aluminio. El dimensionamiento de la estructura acabada deberá calcularse caso por caso y será a cargo del cliente.

Ejemplo:

Carga: 3000 N

Momento de inercia: 10 cm⁴

Distancia apoyos: 800 mm

Le diagramme ci-contre fournit une indication générale de la flexion d'un profilé en aluminium. Le dimensionnement de la structure finie doit être calculé au cas par cas et doit être fourni par le client.

Exemple:

Charge: 3000 N

Moment d'inertie: 10 cm⁴

Espacement des supports: 800 mm

Das nebenstehende Diagramm liefert einen Richtwert der Biegung eines Aluminiumprofils. Die Größe der fertigen Struktur wird von Fall zu Fall vom Kunden berechnet. Beispiel:

Last: 3000 N

Trägheitsmoment: 10 cm⁴

Abstand zwischen den Stützen: 800 mm

SYMBOLS / SIMBOLIAI / SÍMBOLOS / SYMBOLES / SYMBOLE

Griovelio piktograma Legenda / Piktogramos

Legenda icone cava / Leyenda de iconos de ranura / Légende des icônes de fente / Legend of Slot Symbols / Legend of Slot Symbols



Gaminys 20 serijai 6 mm griovelį BH profiliai
 Prodotto per profili serie 20 cava 6 BH Prodotto para
 perfiles con ranura 6 BH serie 20 Produit pour profilés
 rainure 6 BH série 20 Produkt für Profile 6 BH Nut
 Reihe 20



Gaminys 45 serijai 10 mm griovelį BH lengvi profiliai
 Prodotto per profili serie 45 cava 10 BH leggero Prodotto
 para perfiles ranura 10 BH serie 45 ligero Produit pour
 profilés rainure 10 BH série 45 léger Produkt für Profile 10
 BH Nut Reihe 45 leicht



Gaminys 30 serijai 8 mm griovelį BH profiliai
 Prodotto per profili serie 30 cava 8 BH Prodotto para
 perfiles con ranura 8 BH serie 30 Produit pour profilés
 rainure 8 BH série 30 Produkt für Profile 8 BH Nut 8
 Reihe 30



Gaminys 45 serijai 10 mm griovelį BH sunkūs profiliai
 Prodotto per profili serie 45 cava 10 BH pesante Prodotto
 para perfiles ranura 10 BH serie 45 pesado Produit pour
 profilés rainure 10 BH série 45 lourd Produkt für Profile 10
 BH Nut Reihe 45 schwer



Gaminys 40 serijai 10 mm griovelį BH profiliai
 Prodotto per profili serie 40 cava 10 BH Prodotto para
 perfiles con ranura 10 BH serie 40 Produit pour profilés
 rainure 10 BH série 40 Produkt für Profile 10 BH Nut
 Reihe 40



Gaminys 50 serijai 10 mm griovelį BH profiliai
 Prodotto per profili serie 50 cava 10 BH Prodotto para
 perfiles ranura 10 BH serie 50 Produit pour profilés
 rainure 10 BH série 50 Produkt für Profile 10 BH Nut
 Reihe 50

Lentelės piktogramos legenda

Legenda icone tabella / Leyenda de iconos de tabla / Légende des icônes du tableau / Legenda apie stalo simbolius



Dėžė
 Scatola
 Caja Boîte
 dėžutė



Apkrova
 “Portata Carga”
 įkrovimo keliamoji
 galia

Etiketės legenda

Legenda etichette / Leyenda de etiquetas / Légende des étiquettes / Legende der Beschriftungen

STAINLESS STEEL

Nerūdijančio plieno gaminy
 Prodotto in inox
 Nerūdijančio plieno gaminy

ITALIAN PATENT

Patentuotas produktas
 Prodotto brevettato
 Producto patentado
 Produit breveté
 Patentuotas produktas

PATENT

NEW

Naujas produktas
 Prodotto nuovo
 Nuevo producto
 Nouveau produit

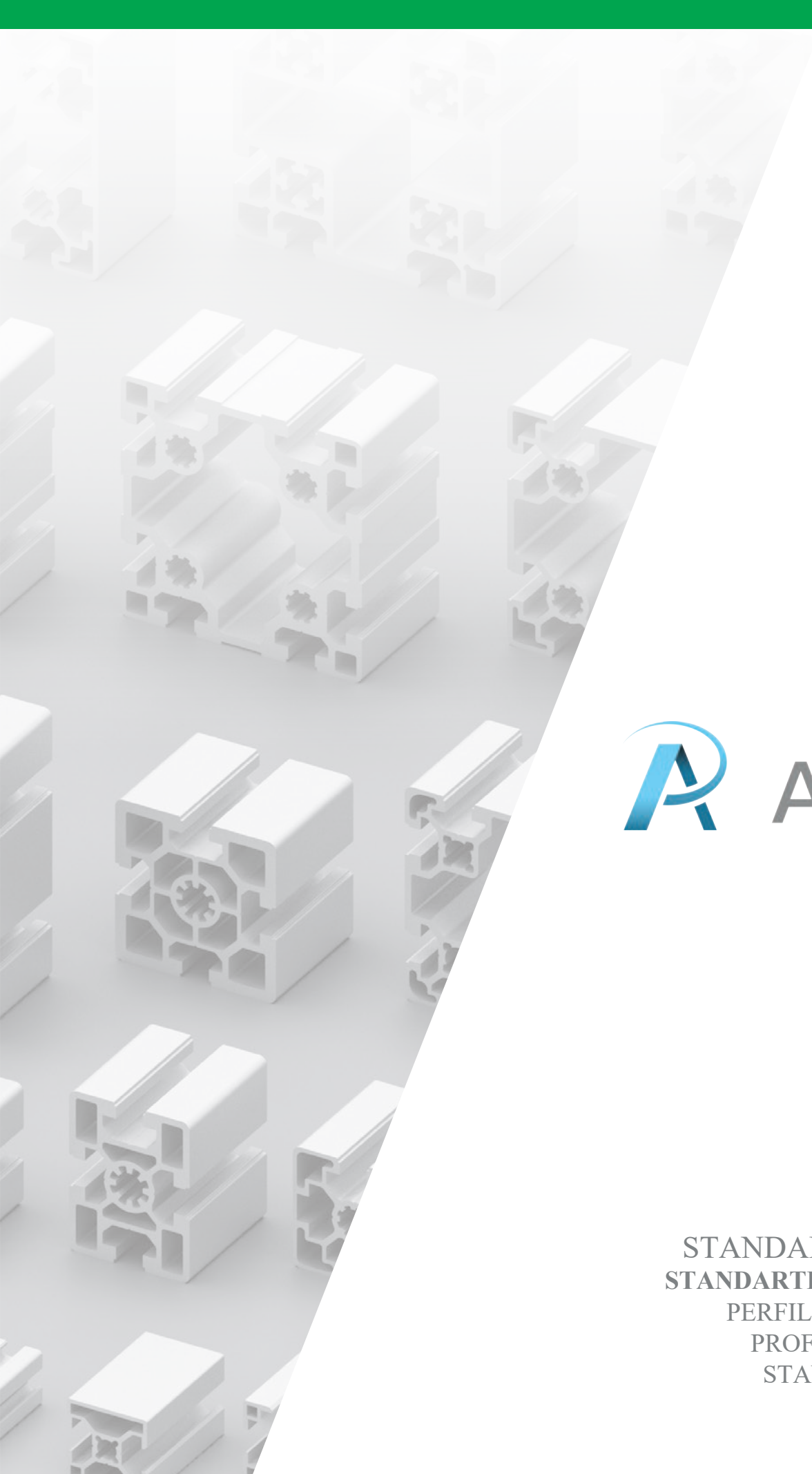

STANDARD PROFILES
STANDARTINIAI PROFILIAI
PERFILES ESTÁNDARES
PROFILÉS STANDARD
STANDARD-PROFILE

ALUSIC STRUCTURAL PROFILES

ALUSIC KONSTRUKCINIAI PROFILIAI / PERFILES ESTRUCTURALES ALUSIC / PROFILÉS STRUCTURELS ALUSIC / KONSTRUKTIONSPROFILE ALUSIC
LT

Visi „Alusic“ katalogo profiliai pagaminti iš aliuminio lydinio ekstruzijos būdu, kurio 60 % yra iš perdirbtų šaltinių. Naudojamas aliuminis tiekiamas kaip T5/T6 grūdintas (atvėsintas karšto apdirbimo / tirpalo terminio apdorojimo ir dirbtinio sendinimo būdu). Strypai paprastai tiekiami su 12 µm anodavimo sluoksniu (pagal pageidavimą dauguma profilių taip pat gali būti tiekiami su frezavimo apdaila). Profilių ekstruzijos metu taikomi tolerancijos nuokrypiai atitinka EN 12020-2 standartą.

IT

Tutti i profili del catalogo Alusic sono realizzati per estrusione di lega di alluminio proveniente al 60% da fonti riciclate. Lo stato metallurgico di fornitura è T5/T6 (solubilizzato, temprato e invecchiato artificialmente). Le barre sono normalmente fornite anodizzate con profondità di trattamento in classe 12 µm (a richiesta la

ES

Todos los perfiles del catálogo de Alusic se fabrican mediante la extrusión de aleación de aluminio, el 60% de la cual proviene de fuentes recicladas. El estado metalúrgico en que se suministran es T5/T6 (solubilizado, templado y envejecido artificialmente). Las barras normalmente se suministran anodizadas, con una profundidad de tratamiento de 12 µm (bajo solicitud, la mayor parte de los perfiles pxuede suministrarse en bruto). Las tolerancias generales conseguidas mediante la extrusión de los perfiles son acordes a la norma UNI-EN 12020-2.

FR

Tous les profils du catalogue Alusic sont réalisés par extrusion d’alliage d’aluminium provenant à 60% de sources recyclées. L’état métallurgique de fourniture est l’état T5/T6 (solubilisé, trempé et vieilli artificiellement). Les barres sont fournies anodisées avec une profondeur de traitement en classe 12 µm (sur demande, la plupart des profilés peuvent être fournis bruts). Les tolérances générales appliquées à l’extrusion des profilés respectent la norme UNI-EN 12020-2.

DE

Alle Profile im Alusic-Katalog werden durch Extrusion von Aluminiumlegierungen hergestellt, wobei 60% aus recycelten Quellen stammen. Der metallurgische Lieferzustand ist T5/T6 (lösungsgeglüht, abgeschreckt aus der Warmumformungstemperatur und warmausgehärtet). Normalerweise werden die Stangen dem Eloxalverfahren unterzogen und haben eine 12 µm dicke Schutzschicht (auf Anfrage sind die meisten der Profile auch ohne Eloxierung erhältlich). Für die Strangpressung der Profile wurden die allgemeinen Toleranzen der Norm UNI EN 12020-2 eingehalten.

CHEMICAL COMPOSITION OF ALLOYS
LYDINIŲ CHEMINĖ SUDĖTIS / COMPOSICIÓN QUÍMICA DE LAS ALEACIONES COMPOSITION
CHIMIQUE DES ALLIAGES / CHEMISCHE ZUSAMMENSETZUNG DER LEGIERUNGEN

EN-AW	Cu	Fe	Mn	Mg	Si	Zn	Cr	Ti	Al
6060	0.10	0.1 - 0.3	0.10	0.35 - 0.6	0.3 - 0.6	0.15	0.05	0.10 nuo	98 % iki 99 %
6063	0.10	0.35	0.10	0.45 - 0.9	0.2 - 0.6	0.10	0.10	0.10 nuo	97,578 % iki 98,5 %

MECHANICAL PROPERTIES
MECHANINĖS SAVYBĖS / CARACTERÍSTICAS MECÁNICAS CARACTÉRISTIQUES MÉCANIQUES /
MECHANISCHE EIGENSCHAFTEN

EN-AW	Rm (N/mm ²)	Rp0,2 (N/mm ²)	A (%)	HB
6060	190	150	8	70
6063	215	170	8	75

PHYSICAL PROPERTIES
FIZINĖS SAVYBĖS / CARACTERÍSTICAS FÍSICAS CARACTÉRISTIQUES PHYSIQUES /
PHYSIKALISCHE EIGENSCHAFTEN

E [N/mm ²]	69000
ρ [Ω mm/m]	0.033
λ W/mK	210
T _m (C°)	615 - 655
α (K ⁻¹)	25X10 ⁻⁶



Alusic

PROFILES SERIES 20 SLOT 6 BH

20 SERIJOS, 6mm GRIOVELIO, BH PROFILIAI
PERFILES SERIE 20 RANURA 6 BH
PROFILÉS SÉRIE 20 RAINURE 6 BH
PROFILE REIHE 20 NUT 6 BH

EN

Alusic series 20 profiles, featuring a 6 mm fastening T-slot, are one of the lightest ranges in the Alusic catalogue.

This range can be fastened with M6 hardware using suitable accessories, or by M6 threading at the ends of the bars. Nuts are available with M4 and M5 threads; they can be inserted at any point in the slot, even following initial assembly of the structure.

LT

„Alusic“ 20 serijos profiliai su 6 mm tvirtinimo T formos griovelio yra vieni lengviausių „Alusic“ kataloge. Šią seriją galima tvirtinti M6 tvirtinimo detalėmis, naudojant tinkamus priedus, arba M6 sriegių strypų galuose. Veržlės tiekiamos su M4 ir M5 sriegiais; jas galima įstatyti bet kurioje griovelio vietoje, net ir po pradinio konstrukcijos surinkimo.

ES

Los perfiles Alusic serie 20, dotados de una ranura de fijación de 6 mm en “T”, conforman una de las líneas más ligeras del catálogo.

La serie permite la fijación con tornillos M6 mediante los correspondientes accesorios de fijación o mediante roscado M6 en los extremos de las barras. En lo que respecta a las tuercas, están disponibles con roscas M4 y M5; pueden insertarse en cualquier punto de la ranura, incluso con posterioridad al primer montaje de la estructura.

FR

Les profilés Alusic série 20, dotés d’une rainure de fixation de 6 mm en « T », constituent une des lignes les plus légères du catalogue.

La série permet la fixation à l’aide de vis M6, au moyen des accessoires de fixation appropriés ou par filetage M6 à l’extrémité des barres. Concernant les écrous, ils sont disponibles avec filetages M4 et M5 ; ils peuvent être introduits à hauteur de tout point de la rainure, y compris après le premier montage de la structure.

DE

Die Alusic-Profile der Reihe 20 mit T-förmiger Befestigungsnut zu 6 mm stellen eine der leichtesten Produktlinien des Katalogs dar.

Die Reihe ermöglicht die Befestigung mit Schrauben M6 durch das geeignete Befestigungszubehör oder durch Gewinde M6 an den Stangenenden. Die Muttern sind mit Gewinden M4 und M5 erhältlich; sie können an jeder Stelle der Nut eingesetzt werden, auch nach der Erstmontage der Struktur.

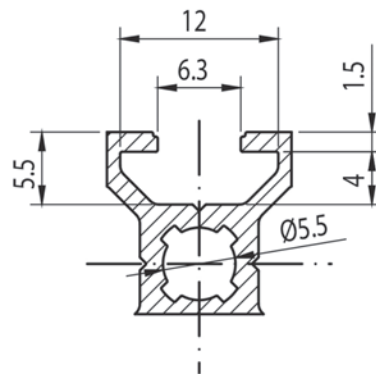

20x20, 6 mm GRIOVELIO BH TIPO KVADRATINIS PROFILIS

Kodas	$I_x \text{ cm}^4$	$I_y \text{ cm}^4$	$w_x \text{ cm}^3$	$w_y \text{ cm}^3$	mm^2	Kg/m
084.111.001	0,67	0,67	0,67	0,67	164,83	0,45



Anodised aluminium
Anodizuotas aliuminis

Natural colour
Spalva natūrali
Couleur naturelle
Natürliche Farbe

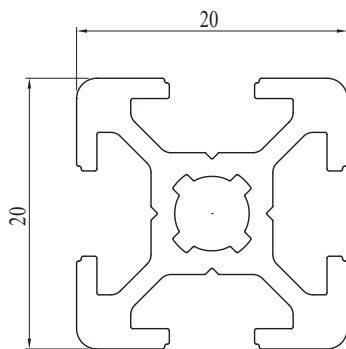

Dangtelis - Cap - Tapòn - Embout - Abdeckkappe			
Kodas	Medž.	g	Sp.
084.201.061		PA2	A
084.201.061G		PA 2	B

20x20, 6 mm GRIOVELIO BH TIPO SFERINIS PROFILIS

Kodas	$I_x \text{ cm}^4$	$I_y \text{ cm}^4$	$w_x \text{ cm}^3$	$w_y \text{ cm}^3$	mm^2	Kg/m
084.111.004	0,44	0,73	0,42	0,69	163,58	0,44



Anodised aluminium
Anodizuotas aliuminis

Natural colour
Spalva natūrali

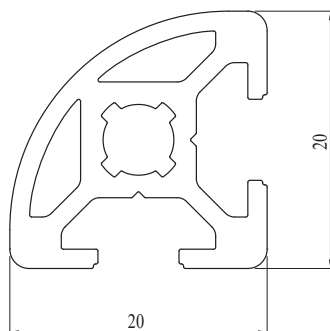

Dangtelis - Cap - Tapòn - Embout - Abdeckkappe			
Kodas	Medž.	g	Sp.
084.201.075		PA3	A
084.201.075G		PA3	B

20x40, 6 mm GRIOVELIO BH TIPO STAČIAKAMPIS PROFILIS



Kodas	lx cm ⁴	ly cm ⁴	wx cm ³	wy cm ³	mm ²	Kg/m
084.111.002	4,64	1,20	1,32	1,20	289,70	0,78



Anodised aluminium
Anodizuotas aliuminis

Natural colour
Spalva natūrali

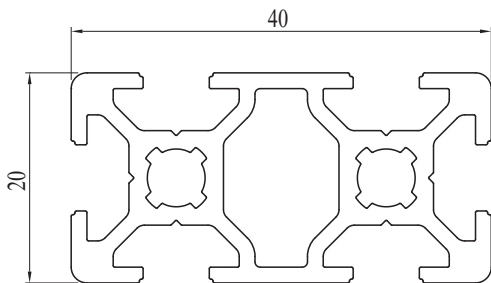

Dangtelis - Cap - Tapòn - Embout - Abdeckkappe			
Kodas	Medž.	g	Sp.
084.201.062	PA	3	A
084.201.062G	PA	3	B

SURINKIMO SISTEMOS

SISTEMI DI MONTAGGIO
SISTEMAS DE MONTAJE
SISTÉMES DE MONTAGE
MONTAGESYSTEME

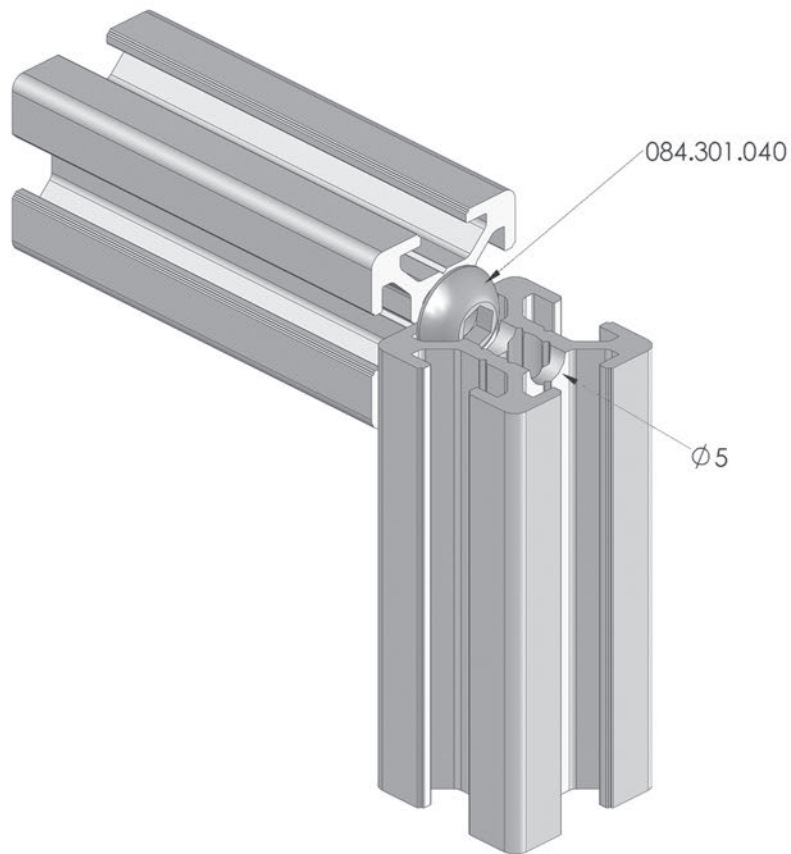





PROFILES SERIES 30 SLOT 8 BH

30 SERIJOS 8 mm GRIOVELIO BH PROFILIAI
PERFILES SERIE 30 RANURA 8 BH
PROFILÉS SÉRIE 30 RAINURE 8 BH
PROFILE REIHE 30 NUT 8 BH

EN

Alusic series 30 profiles, featuring an 8 mm fastening T-slot, are one of the ranges with the best strength-weight ratios.

This range can be fastened with M8 hardware using suitable accessories, or by M8 threading at the ends of the bars. Nuts are available with M4, M5 and M6 threads; they can be inserted at any point in the slot, even following initial assembly of the structure.

LT

„Alusic“ 30 serijos profiliai su 8 mm tvirtinimo T formos griovelio yra vieni iš geriausių stiprumo ir svorio santykio modelių. Šio modelio gaminius galima tvirtinti M8 tvirtinimo detalėmis, naudojant tinkamus priedus, arba M8 sriegiu strypų galuose. Veržlės tiekiamos su M4, M5 ir M6 sriegiais; jas galima įstatyti bet kurioje griovelio vietoje, net ir po pradinio konstrukcijos surinkimo..

ES

Los perfiles Alusic serie 30, dotados de una ranura de fijación de 8 mm en “T”, conforman una de las líneas con la mejor relación peso-resistencia mecánica.

La serie permite la fijación con tornillos M8 mediante los correspondientes accesorios de fijación o mediante roscado M8 en los extremos de las barras. En lo que respecta a las tuercas, están disponibles con roscas M4, M5 y M6; pueden insertarse en cualquier punto de la ranura, incluso con posterioridad al primer montaje de la estructura.

FR

Les profilés Alusic série 30, dotés d’une rainure de fixation de 8 mm en « T », représentent l’une des lignes offrant le meilleur rapport poids/résistance mécanique.

La série permet la fixation à l’aide de vis M8, au moyen des accessoires de fixation appropriés ou par filetage M8 à l’extrémité des barres. Concernant les écrous, ils sont disponibles avec filetages M4, M5 et M6 ; ils peuvent être introduits à hauteur de tout point de la rainure, y compris après le premier montage de la structure.

DE

Die Alusic-Profile der Reihe 30 mit T-förmiger Befestigungsnut zu 8 mm stellen eine der Produktlinien mit dem besten Verhältnis zwischen Gewicht und mechanischer Festigkeit dar.

Die Reihe ermöglicht die Befestigung mit Schrauben M8 durch das geeignete Befestigungszubehör oder durch Gewinde M8 an den Stangenenden. Die Muttern sind mit Gewinden M4, M5 und M6 erhältlich; sie können an jeder Stelle der Nut auch nach der Erstmontage der Struktur eingesetzt werden.

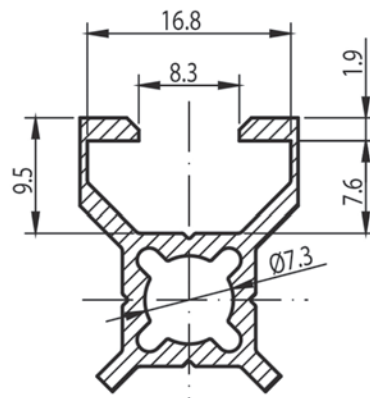

30x30, 8 mm GRIOVELIO KVADRATINIS BH TIPO PROFILIS



Kodas	lx cm ⁴	ly cm ⁴	wx cm ³	wy cm ³	mm ²	Kg/m
084.107.002	2,60	2,60	1,73	1,73	273	0,74

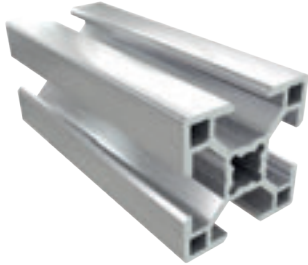

Anodised aluminium
Anodizuotas aliuminis

Natural colour
Spalva natūrali

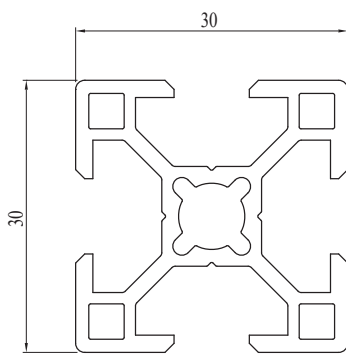

Dangtelis - Cap - Tapòn - Embout - Abdeckkappe			
Kodas	Medž.	g	Sp.
084.201.041	PA	3	A
084.201.041G	PA	3	B

30x30, 8 mm GRIOVELIO KVADRATINIS, IŠ VIENOS PUSĖS UŽDARAS BH TIPO PROFILIS



Kodas	lx cm ⁴	ly cm ⁴	wx cm ³	wy cm ³	mm ²	Kg/m
084.107.006	2,54	2,68	1,70	1,77	275	0,74

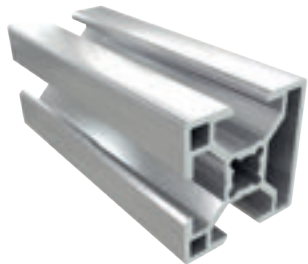

Anodised aluminium
Anodizuotas aliuminis

Natural colour
Spalva natūrali

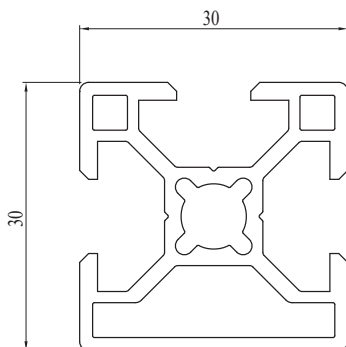

Dangtelis - Cap - Tapòn - Embout - Abdeckkappe			
Kodas	Medž.	g	Sp.
084.201.041	PA	3	A
084.201.041G	PA	3	B

30x30, 8 mm GRIOVELIO KVADRATINIS, IŠ 3 PUSIŲ UŽDARAS BH TIPO PROFILIS

NEW



Kodas	lx cm ⁴	ly cm ⁴	wx cm ³	wy cm ³	mm ²	Kg/m
084.107.008	2,73	2,63	1,82	1,75	282	0,76



Anodised aluminium
Anodizuotas aliuminis

Natural colour
Spalva natūrali

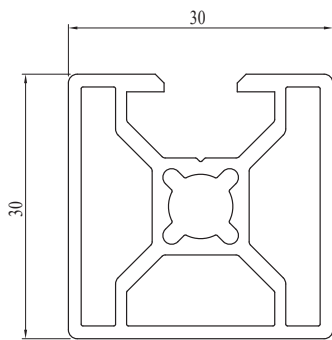

Dangtelis - Cap - Tapòn - Embout - Abdeckkappe			
Kodas	Medž.	g	Sp.
084.201.041	PA	3	A
084.201.041G	PA	3	B

30x30, 8 mm GRIOVELIO KVADRATINIS, IŠ 2 PUSIŲ UŽDARAS BH TIPO PROFILIS

NEW



Kodas	lx cm ⁴	ly cm ⁴	wx cm ³	wy cm ³	mm ²	Kg/m
084.107.011	9,29	124,44	6,39	20,74	428	2,51

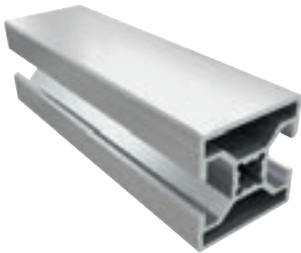

Anodised aluminium
Anodizuotas aliuminis

Natural colour
Spalva natūrali

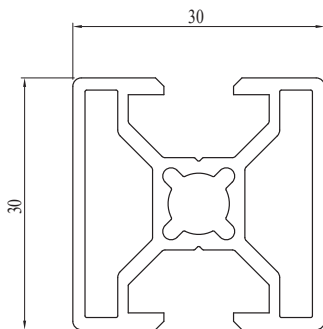

Dangtelis - Cap - Tapòn - Embout - Abdeckkappe			
Kodas	Medž.	g	Sp.
084.201.041	PA	3	A
084.201.041G	PA	3	B

30x30, 8 mm GRIOVELIO KVADRATINIS, IŠ 2 GRETIMŲ PUSIŲ UŽDARAS BH TIPO PROFILIS

NEW

BH
30

Kodas	lx cm ⁴	ly cm ⁴	wx cm ³	wy cm ³	mm ²	Kg/m
084.107.009	2,54	2,54	1,69	1,69	262	0,71



Anodised aluminium
Anodizuotas aliuminis

Natural colour
Spalva natūrali

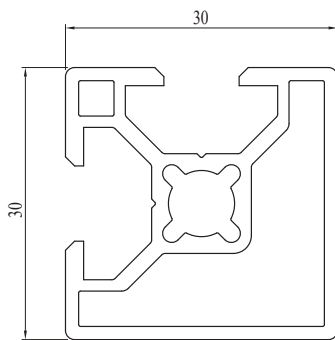

Dangtelis - Cap - Tapòn - Embout - Abdeckkappe			
Kodas	Medž.	g	Sp.
084.201.041	PA	3	A
084.201.041G	PA	3	B

30x30, 8 mm SFERINIS BH TIPO PROFILIS
BH
30

Kodas	lx cm ⁴	ly cm ⁴	wx cm ³	wy cm ³	mm ²	Kg/m
084.107.005	1,84	2,88	1,23	1,92	289,13	0,78



Anodised aluminium
Anodizuotas aliuminis

Natural colour
Spalva natūrali

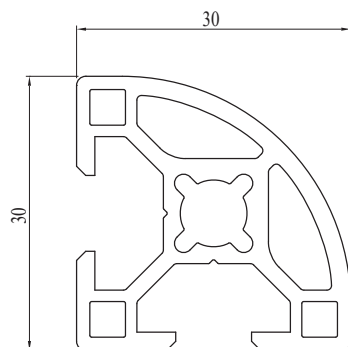

Dangtelis - Cap - Tapòn - Embout - Abdeckkappe			
Kodas	Medž.	g	Sp.
084.201.063	PA	3	A
084.201.063G	PA	3	B

30x60, 8 mm GRIOVELIO STAČIAKAMPIS BH TIPO PROFILIS





Kodas	lx cm ⁴	ly cm ⁴	wx cm ³	wy cm ³	mm ²	Kg/m
084.107.003	17,54	4,57	5,85	3,05	487	1,32

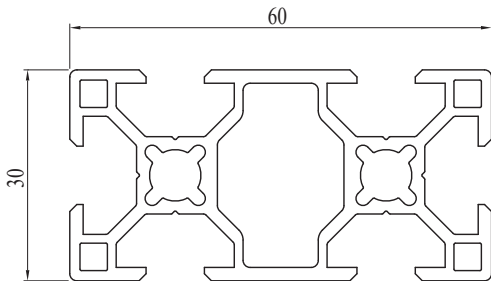

Anodised aluminium
Anodizuotas aliuminis

Natural colour
Spalva natūrali

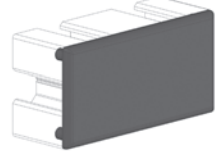

Dangtelis - Cap - Tapòn - Embout - Abdeckkappe			
			
		2,5	
Kodas	Medž.	g	Sp.
084.201.042	PA	6	A
084.201.042G	PA	6	B

30x60, 8 mm GRIOVELIO, STAČIAKAMPIS, IŠ 2 PUSIŲŪŽDARAS BH TIPO PROFILIS

NEW





Kodas	lx cm ⁴	ly cm ⁴	wx cm ³	wy cm ³	mm ²	Kg/m
084.107.010	17,03	4,72	5,68	3,15	476	1,29

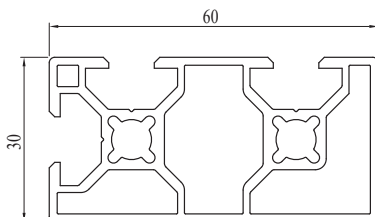

Anodised aluminium
Anodizuotas aliuminis

Natural colour
Spalva natūrali

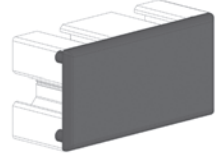

Dangtelis - Cap - Tapòn - Embout - Abdeckkappe			
			
		2,5	
Kodas	Medž.	g	Sp.
084.201.042	PA	6	A
084.201.042G	PA	6	B

**30x120, 8 mm GRIOVELIO, STAČIAKAMPIS
BH TIPO PROFILIS**

NEW



Kodas	lx cm ⁴	ly cm ⁴	wx cm ³	wy cm ³	mm ²	Kg/m
084.107.012	8,33	45,21	5,55	30,14	274	0,74



Anodised aluminium
Anodizuotas aliuminis

Natural colour
Spalva natūrali

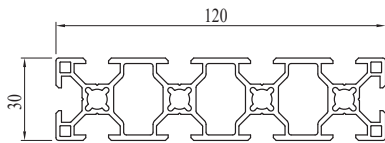

60x60, 8 mm GRIOVELIO, KVADRATINIS, BH TIPO PROFILIS





Kodas	lx cm ⁴	ly cm ⁴	wx cm ³	wy cm ³	mm ²	Kg/m
084.107.004	33,79	33,79	11,26	11,26	856,60	2,30

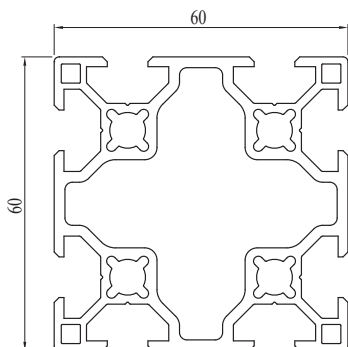

Anodised aluminium
Anodizuotas aliuminis

Natural colour
Spalva natūrali

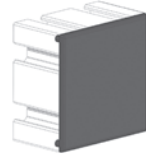

Dangtelis - Cap - Tapòn - Embout - Abdeckkappe			
			
Kodas	Medž.	g	Sp.
084.201.057	PA	12	A
084.201.057G	PA	12	B

**60x60, 8 mm GRIOVELIO
KVADRATINIS, BH TIPO PROFILIS**

NEW



Kodas	lx cm ⁴	ly cm ⁴	wx cm ³	wy cm ³	mm ²	Kg/m
084.107.007	37,49	37,49	12,49	12,49	923,6	2,5



Anodised aluminium
Anodizuotas aliuminis

Natural colour
Spalva natūrali

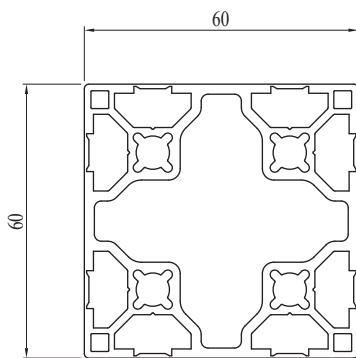

Dangtelis - Cap - Tapòn - Embout - Abdeckkappe			
Kodas	Medž.	g	Sp.
084.201.057	PA	12	A
084.201.057G	PA	12	B

MONTAVIMO SISTEMOS

SISTEMI DI MONTAGGIO
SISTEMAS DE MONTAJE
SISTÈMES DE MONTAGE
MONTAGESYSTEME

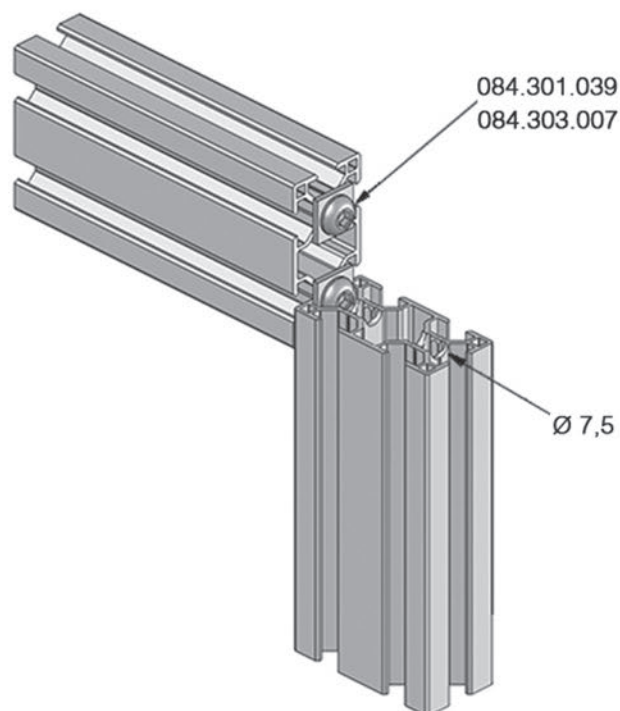
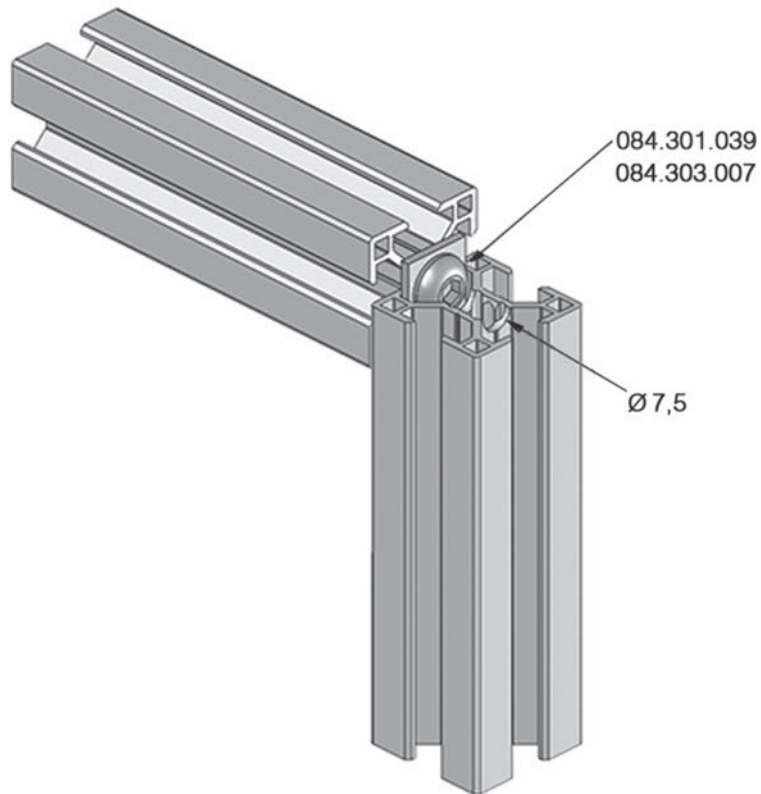





PROFILES SERIES 40 SLOT 10 BH

40 SERIJOS, 10 mm GRIOVELIO BH PROFILIAI
PERFILES SERIE 40 RANURA 10 BH
PROFILÉS SÉRIE 40 RAINURE 10 BH
PROFILE REIHE 40 NUT 10 BH

EN

Alusic series 40 profiles, featuring a 10 mm fastening T-slot, represent the perfect compromise between lightness and solidity.

This range can be fastened with M8 hardware using suitable accessories, or by M12 threading at the ends of the bars. Nuts are available with M4, M5, M6 and M8 threads; they can be inserted at any point in the slot, even following initial assembly of the structure.

LT

„Alusic“ 40 serijos profiliai su 10 mm tvirtinimo T formos grioveliu yra puikus kompromisas tarp lengvumo ir tvirtumo. Šio asortimento gaminius galima tvirtinti M8 tvirtinimo detalėmis, naudojant tinkamus priedus, arba M12 sriegių strypų galuose. Veržlės tiekiamos su M4, M5, M6 ir M8 sriegiais; jas galima įstatyti bet kurioje griovelio vietoje, net ir po pradinio konstrukcijos surinkimo.

ES

Los perfiles Alusic serie 40, dotados de una ranura de fijación de 10 mm en “T”, ofrecen un equilibrio perfecto entre ligereza y robustez.

La serie permite la fijación con tornillos M8 mediante los correspondientes accesorios de fijación o mediante roscado M12 en los extremos de las barras. En lo que respecta a las tuercas, están disponibles con roscas M4, M5, M6 y M8; pueden insertarse en cualquier punto de la ranura, incluso con posterioridad al primer montaje de la estructura.

FR

Les profilés Alusic série 40, dotés d’une rainure de fixation de 10 mm en « T », représentent le juste compromis entre légèreté et robustesse.

La série permet la fixation à l’aide de vis M8, au moyen des accessoires de fixation appropriés ou par filetage M12 à l’extrémité des barres. Concernant les écrous, ils sont disponibles avec filetages M4, M5, M6 et M8 ; ils peuvent être introduits à hauteur de tout point de la rainure, y compris après le premier montage de la structure.

DE

Die Alusic-Profilе der Reihe 40 mit T-förmiger Befestigungsnut zu 10 mm stellen die richtige Mischung zwischen Leichtigkeit und Robustheit dar.

Die Reihe ermöglicht die Befestigung mit Schrauben M8 durch das geeignete Befestigungszubehör oder durch Gewinde M12 an den Stangenenden. Die Muttern sind mit Gewinden M4, M5, M6 und M8 erhältlich; sie können an jeder Stelle der Nut auch nach der Erstmontage der Struktur eingesetzt werden.

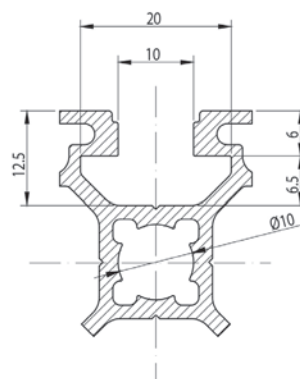

40x40, 10 mm GRIOVELIO, BH TIPO KVADRATINIS PROFILIS

BH
10
40

Kodas	lx cm ⁴	ly cm ⁴	wx cm ³	wy cm ³	mm ²	Kg/m
084.113.001	8,89	8,89	4,45	4,45	553,50	1,49

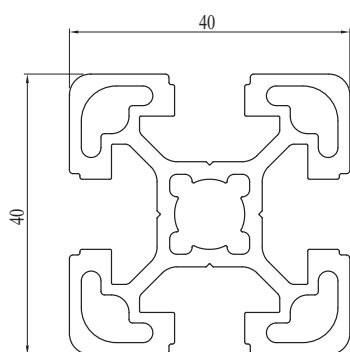
Anodised aluminium
Anodizuotas aliuminisNatural colour
Spalva natūrali

Dangtelis - Cap - Tapòn - Embout - Abdeckkappe			
Kodas	Medž.	g	Sp.
084.201.064	PA	5	A
084.201.064G	PA	5	B

40x80, 10 mm GRIOVELIO, BH TIPO STAČIAKAMPIS PROFILIS

BH
10
40

Kodas	lx cm ⁴	ly cm ⁴	wx cm ³	wy cm ³	mm ²	Kg/m
084.113.002	62,26	17,35	15,57	8,68	979,60	2,64

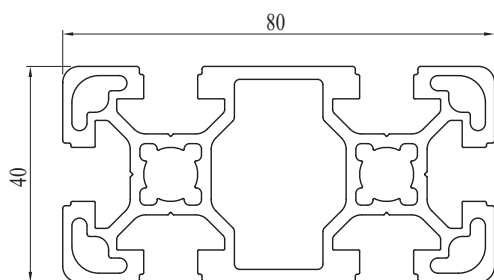
Anodised aluminium
Anodizuotas aliuminisNatural colour
Spalva natūrali

Dangtelis - Cap - Tapòn - Embout - Abdeckkappe			
Kodas	Medž.	g	Sp.
084.201.065	PA	10	A
084.201.065G	PA	10	B

80x80, 10 mm GRIOVELIO, BH TIPO KVADRATINIS PROFILIS



Kodas	lx cm ⁴	ly cm ⁴	wx cm ³	wy cm ³	mm ²	Kg/m
084.113.003	114,55	114,55	28,64	28,64	1554,20	4,20



Anodised aluminium
Anodizuotas aliuminis

Natural colour
Spalva natūrali

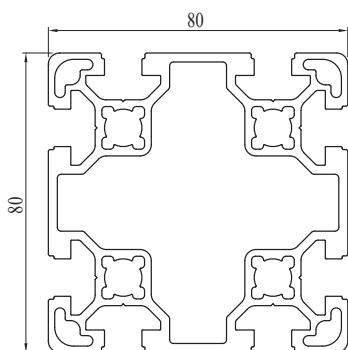

Dangtelis - Cap - Tapòn - Embout - Abdeckkappe			
Kodas	Medž.	g	Sp.
084.201.066	PA	18	A
084.201.066G	PA	18	B

MTAVIMO SISTEMOS

SISTEMI DI MONTAGGIO
SISTEMAS DE MONTAJE
SISTÉMES DE MONTAGE
MONTAGESYSTEME

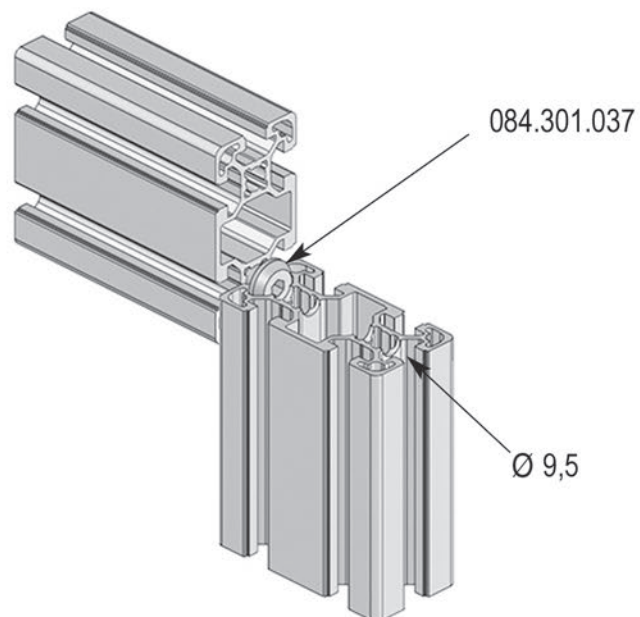
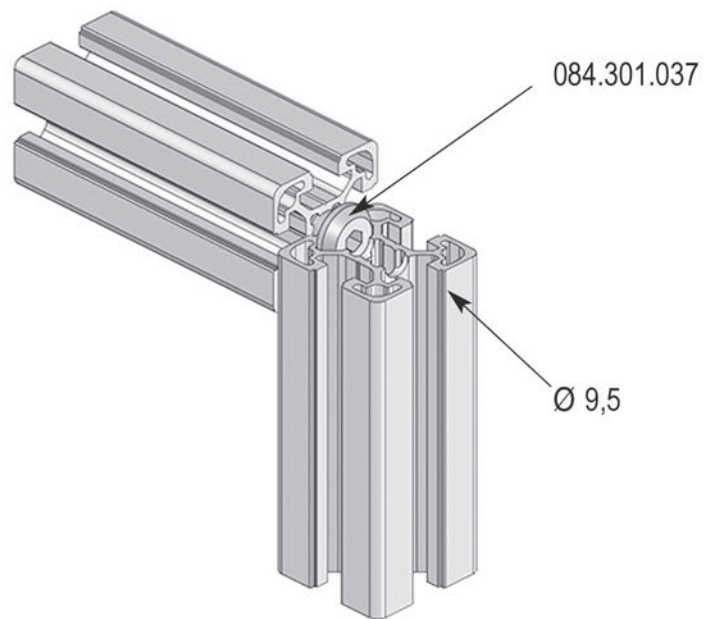





PROFILES SERIES 45 SLOT 10 BH

45 SERIJOS, 10 mm GRIOVELIO BH PROFILIAI
PERFILES SERIE 45 RANURA 10 BH
PROFILÉS SÉRIE 45 RAINURE 10 BH
PROFILE REIHE 45 NUT 10 BH

EN

Alusic series 45 profiles, featuring a 10 mm fastening T-slot, are one of the most popular ranges in the Alusic catalogue.

The range is completed by profiles with closed or tear-off slots, ideal for the food sector; it is also the base for our "FC Heavy" model range.

This range can be fastened with M8 hardware using suitable accessories, or by M12 threading at the ends of the bars. Nuts, also available in spring channel version, are available with M4, M5, M6 and M8 threads; they can be inserted at any point in the slot, even following initial assembly of the structure.

LT

„Alusic 45“ serijos profiliai su 10 mm „T“ formos tvirtinimo angomis yra viena iš dažniausiai naudojamų „Alusic“ katalogo serijų. Šią seriją sudaro profiliai su uždara arba nulupama angomis, idealiai tinkantys maisto sektoriui, ir jie taip pat yra „FC Heavy“ linijos modelių pagrindas. Seriją galima tvirtinti M8 varžtais, naudojant atitinkamus tvirtinimo priedus, arba M12 sriegiais strypų galuose. Veržlės, taip pat tiekiamos spyruoklinės versijos, yra su M4, M5, M6 ir M8 sriegiais; jas galima įstatyti bet kurioje angos vietoje net ir po pradinio konstrukcijos surinkimo.

ES

Los perfiles Alusic serie 45, dotados de una ranura de fijación de 10 mm en "T", conforman una de las gamas más utilizadas del catálogo de Alusic.

La gama ofrece perfiles con ranuras cerradas o desgarrables, ideales para el sector alimentario, y además sirve de base para los modelos de la línea "FC Heavy".

La serie permite la fijación con tornillos M8 mediante los correspondientes accesorios de fijación o mediante roscado M12 en los extremos de las barras. En lo que respecta a las tuercas, también presentes en la versión con muelle, están disponibles con roscas M4, M5, M6 y M8; pueden insertarse en cualquier punto de la ranura, incluso con posterioridad al primer montaje de la estructura.

FR

Les profilés Alusic série 45, dotés d'une rainure de fixation de 10 mm en « T », constituent l'une des gammes les plus utilisées du catalogue Alusic.

La gamme comprend des profilés à rainures fermées ou pelables, idéals pour le secteur alimentaire ; de plus, elle constitue la base des modèles de la ligne « FC Heavy ».

La série permet la fixation à l'aide de vis M8, au moyen des accessoires de fixation appropriés ou par filetage M12 à l'extrémité des barres. Concernant les écrous, également présents dans la version à ressort, ils sont disponibles avec filetages M4, M5, M6 et M8 ; ils peuvent être introduits à hauteur de tout point de la rainure, y compris après le premier montage de la structure.

DE

Die Alusic-Profilе der Reihe 45 mit T-förmiger Befestigungsnut zu 10 mm stellen eine der meist verwendeten Produktreihen des Alusic-Katalogs dar.

Die Produktreihe wird durch Profile mit geschlossenen oder schälbaren Nuten vervollständigt, die ideal für die Lebensmittelbranche sind; außerdem ist sie die Grundlage für die Modelle der Produktreihe „FC Heavy“.

Die Reihe ermöglicht die Befestigung mit Schrauben M8 durch das geeignete Befestigungszubehör oder durch Gewinde M12 an den Stangenenden. Die Muttern, die auch in der Ausführung mit Feder vorhanden sind, sind mit Gewinden M4, M5, M6 und M8 erhältlich; sie können an jeder Stelle der Nut auch nach der Erstmontage der Struktur eingesetzt werden.

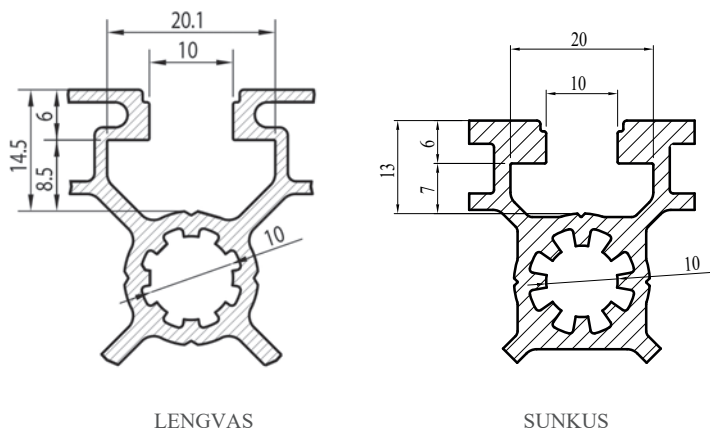

45x45, 10 mm GRIOVELIO, BH TIPO KVADRATINIAI PROFILIAI





Kodas	lx cm ⁴	ly cm ⁴	wx cm ³	wy cm ³	mm ²	Kg/m
084.105.004	11,33	11,33	5,04	5,04	573	1,56

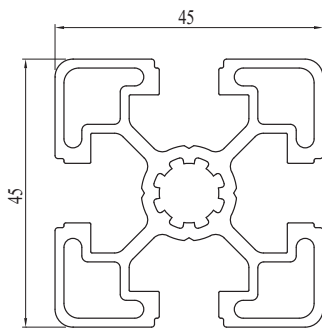

Anodised aluminium
Anodizuotas aliuminis

Natural colour
Spalva natūrali

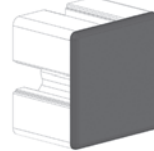

Dangtelis - Cap - Tapòn - Embout - Abdeckkappe			
			
Kodas	Medž.	g	Sp.
084.201.038	PA	7	A
084.201.038G	PA	7	B

45x45, 10 mm GRIOVELIO, BH TIPO, 1 UŽDAROS PUSĖS KVADRATINIAI PROFILIAI





Kodas	lx cm ⁴	ly cm ⁴	wx cm ³	wy cm ³	mm ²	Kg/m
084.105.010	10,89	11,68	4,75	5,07	582,70	1,57

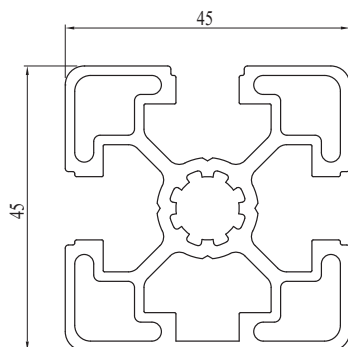

Anodised aluminium
Anodizuotas aliuminis

Natural colour
Spalva natūrali

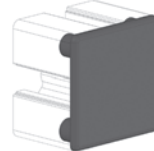

Dangtelis - Cap - Tapòn - Embout - Abdeckkappe			
			
Kodas	Medž.	g	Sp.
084.201.038	PA	7	A
084.201.038G	PA	7	B

45x45, 10 mm GRIOVELIO, BH TIPO, KVADRATINIAI, IŠ DVIEJŲ PUSIŲ UŽDARI PROFILIAI



Kodas	lx cm ⁴	ly cm ⁴	wx cm ³	wy cm ³	mm ²	Kg/m
084.105.011	11,70	11,70	5,10	5,10	600	1,62



Anodised aluminium
Anodizuotas aliuminis

Natural colour
Spalva natūrali

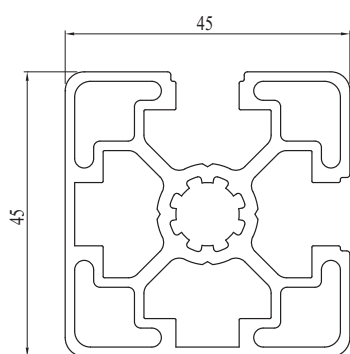

Dangtelis - Cap - Tapòn - Embout - Abdeckkappe			
Kodas	Medž.	g	Sp.
084.201.038	PA	7	A
084.201.038G	PA	7	B

45x45, 10 mm GRIOVELIO, BH TIPO, KVADRATINIAI, IŠ 3 PUSIŲ UŽDARI PROFILIAI



Kodas	lx cm ⁴	ly cm ⁴	wx cm ³	wy cm ³	mm ²	Kg/m
084.105.015	11,00	11,20	4,90	4,98	555,94	1,50



Anodised aluminium
Anodizuotas aliuminis

Natural colour
Spalva natūrali

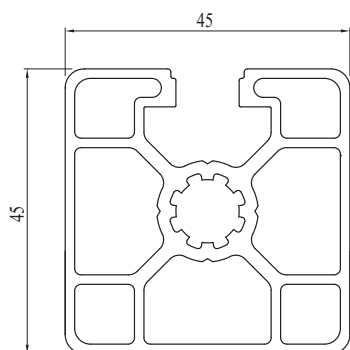

Dangtelis - Cap - Tapòn - Embout - Abdeckkappe			
Kodas	Medž.	g	Sp.
084.201.038	PA	7	A
084.201.038G	PA	7	B

45x45, 10 mm GRIOVELIO, BH TIPO, SFERINIAI PROFILIAI

Kodas	lx cm ⁴	ly cm ⁴	wx cm ³	wy cm ³	mm ²	Kg/m
084.105.012	8,37	8,37	3,35	3,35	476	1,29



Anodised aluminium
Anodizuotas aliuminis

Natural colour
Spalva natūrali

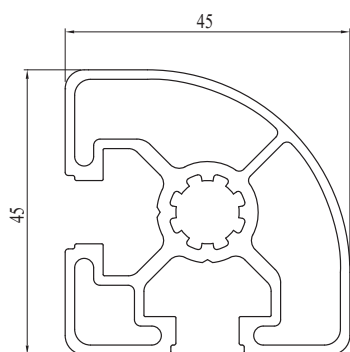

Dangtelis - Cap - Tapòn - Embout - Abdeckkappe			
Kodas	Medž.	g	Sp.
084.201.071	PA	7	A
084.201.071G	PA	7	B

45x45, 10 mm GRIOVELIO, BH TIPO KVADRATINIAI PROFILIAI

Kodas	lx cm ⁴	ly cm ⁴	wx cm ³	wy cm ³	mm ²	Kg/m
084.105.018	14,82	14,82	6,59	6,59	750,45	2,03



Anodised aluminium
Anodizuotas aliuminis
Aluminio anodizado
Aluminium anodisé
Eloxiertes Aluminium
L=6040 mm

Natural colour
Spalva natūrali

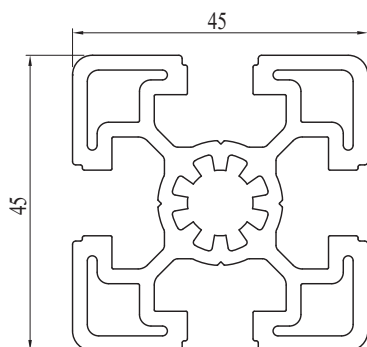

Dangtelis - Cap - Tapòn - Embout - Abdeckkappe			
Kodas	Medž.	g	Sp.
084.201.038	PA	7	A
084.201.038G	PA	7	B

45x60, 10 mm GRIOVELIO, BH TIPO STAČIAKAMPIAI PROFILIAI



Kodas	lx cm ⁴	ly cm ⁴	wx cm ³	wy cm ³	mm ²	Kg/m
084.105.007	35,00	20,90	11,70	9,30	1038	2,80

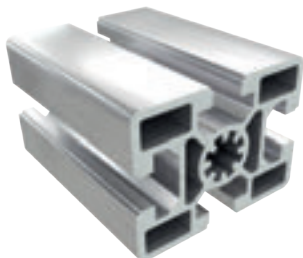

Anodised aluminium
Anodizuotas aliuminis

Natural colour
Spalva natūrali

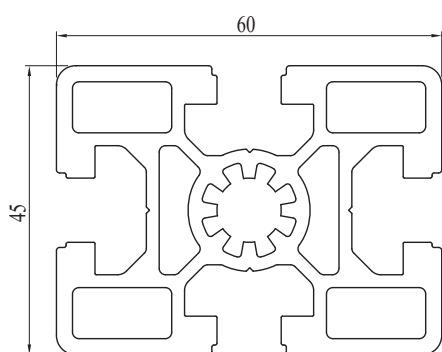

Dangtelis - Cap - Tapòn - Embout - Abdeckkappe			
Kodas	Medž.	g	Sp.
084.201.052	PA	11	A
084.201.052G	PA	11	B

45x90, 10 mm GRIOVELIO, BH TIPO STAČIAKAMPIAI PROFILIAI



Kodas	lx cm ⁴	ly cm ⁴	wx cm ³	wy cm ³	mm ²	Kg/m
084.105.006	82,27	23,49	18,28	10,44	1132	2,86



Anodised aluminium
Anodizuotas aliuminis

Natural colour
Spalva natūrali

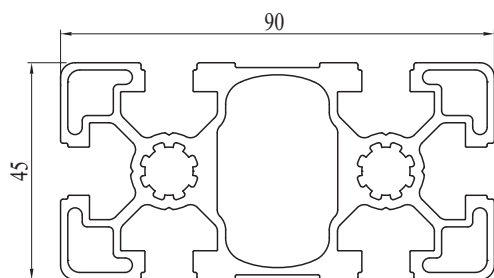

Dangtelis - Cap - Tapòn - Embout - Abdeckkappe			
Kodas	Medž.	g	Sp.
084.201.039	PA	12	A
084.201.039G	PA	12	B

45x90, 10 mm GRIOVELIO, BH TIPO STAČIAKAMPIAI PROFILIAI

BH
10
45

Kodas	lx cm ⁴	ly cm ⁴	wx cm ³	wy cm ³	mm ²	Kg/m
084.105.019	125,7	32,9	27,95	14,65	1519,1	4,12

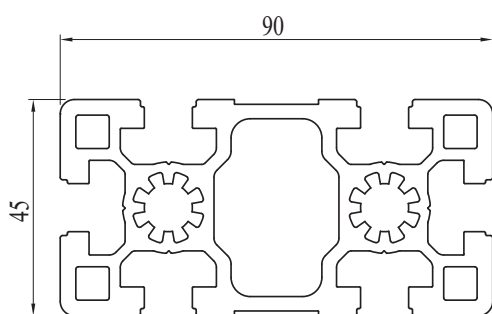
Anodised aluminium
Anodizuotas aliuminisNatural colour
Spalva natūrali

Dangtelis - Cap - Tapòn - Embout - Abdeckkappe			
Kodas	Medž.	g	Sp.
084.201.039	PA	12	A
084.201.039G	PA	12	B

60x60, 10 mm GRIOVELIO, BH TIPO, KVADRATINIAI PROFILIAI

BH
10
45

Kodas	lx cm ⁴	ly cm ⁴	wx cm ³	wy cm ³	mm ²	Kg/m
084.105.008	52,57	52,57	17,52	17,52	1416	3,82

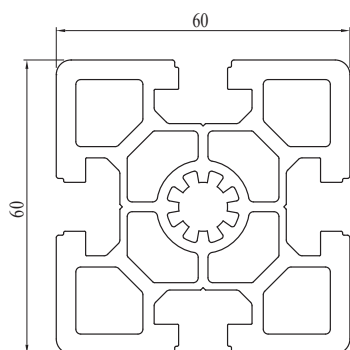
Anodised aluminium
Anodizuotas aliuminisNatural colour
Spalva natūrali

Dangtelis - Cap - Tapòn - Embout - Abdeckkappe			
Kodas	Medž.	g	Sp.
084.201.067	PA	18	A
084.201.067G	PA	18	B

90x90, 10 mm GRIOVELIO, BH TIPO, KVADRATINIAI PROFILIAI



Kodas	lx cm ⁴	ly cm ⁴	wx cm ³	wy cm ³	mm ²	Kg/m
084.105.005	174,93	174,93	38,97	38,97	1796	4,86



Anodised aluminium
Anodizuotas aliuminis

Natural colour
Spalva natūrali

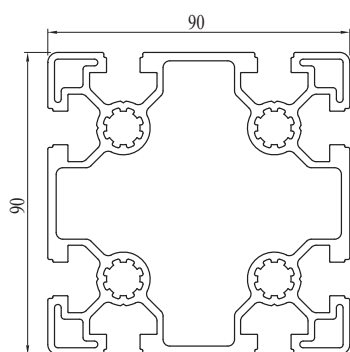

Dangtelis - Cap - Tapòn - Embout - Abdeckkappe			
Kodas	Medž.	g	Sp.
084.201.040	PA	22	A
084.201.040G	PA	22	B

90x90, 10 mm GRIOVELIO, BH TIPO KVADRATINIAI PROFILIAI



Kodas	lx cm ⁴	ly cm ⁴	wx cm ³	wy cm ³	mm ²	Kg/m
084.105.014	219,32	219,32	48,74	48,74	2406	6,50



Anodised aluminium
Anodizuotas aliuminis

Natural colour
Spalva natūrali

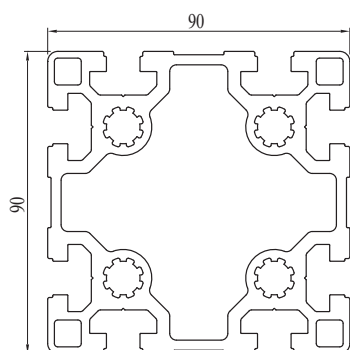

Dangtelis - Cap - Tapòn - Embout - Abdeckkappe			
Kodas	Medž.	g	Sp.
084.201.040	PA	22	A
084.201.040G	PA	22	B

90x90, 10 mm GRIOVELIO, BH TIPO KVADRATINIAI PROFILIAI

Kodas	lx cm ⁴	ly cm ⁴	wx cm ³	wy cm ³	mm ²	Kg/m
084.105.009	187,50	187,50	41,67	41,67	2170,20	5,86

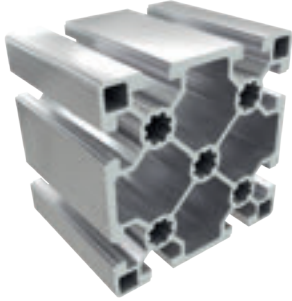

Anodised aluminium
Anodizuotas aliuminis

Natural colour
Spalva natūrali

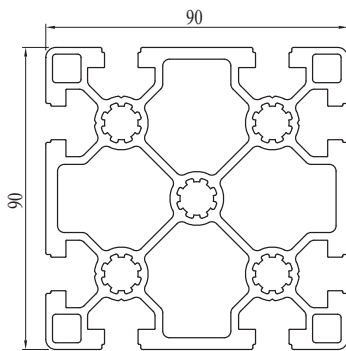

Dangtelis - Cap - Tapòn - Embout - Abdeckkappe			
Kodas	Medž.	g	Sp.
084.201.040	PA	22	A
084.201.040G	PA	22	B

90x90, 10 mm GRIOVELIO, BH TIPO KVADRATINIAI PROFILIAI

Kodas	lx cm ⁴	ly cm ⁴	wx cm ³	wy cm ³	mm ²	Kg/m
084.105.016	173,53	173,53	38,56	38,56	1749	4,72



Anodised aluminium
Anodizuotas aliuminis

Natural colour
Spalva natūrali

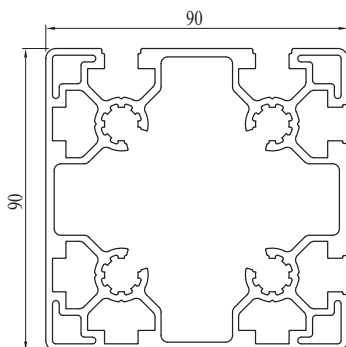

Dangtelis - Cap - Tapòn - Embout - Abdeckkappe			
Kodas	Medž.	g	Sp.
084.201.040	PA	22	A
084.201.040G	PA	22	B

90x90, 10 mm GRIOVELIO, BH TIPO KVADRATINIAI PROFILIAI

BH L
10
45

Kodas	lx cm ⁴	ly cm ⁴	wx cm ³	wy cm ³	mm ²	Kg/m
084.105.017	165,24	171,42	36,72	38	1705	4,60



Anodised aluminium
Anodizuotas aliuminis

Natural colour
Spalva natūrali

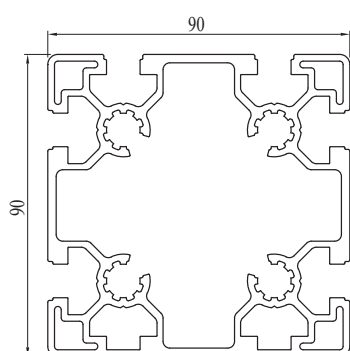

Dangtelis - Cap - Tapòn - Embout - Abdeckkappe			
Kodas	Medž.	g	Sp.
084.201.040	PA	22	A
084.201.040G	PA	22	B

90x180, 10 mm GRIOVELIO, BH TIPO STAČIAKAMPIAI PROFILIAI

BH H
10
45

Kodas	lx cm ⁴	ly cm ⁴	wx cm ³	wy cm ³	mm ²	Kg/m
084.105.013	1430,10	418,90	158,33	93,09	4323	11,67



Anodised aluminium
Anodizuotas aliuminis

Natural colour
Spalva natūrali

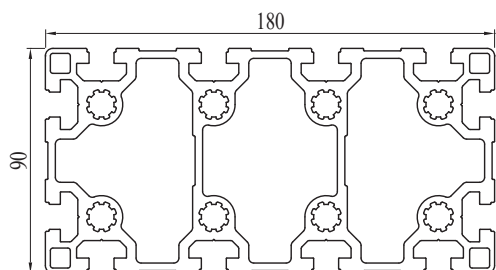

Dangtelis - Cap - Tapòn - Embout - Abdeckkappe			
Kodas	Medž.	g	Sp.
084.201.074	PA	18	A
084.201.074G	PA	18	B

135x225, 10 mm GROVELIO, BH TIPO STAČIAKAMPIAI PROFILIAI



Kodas	lx cm ⁴	ly cm ⁴	wx cm ³	wy cm ³	mm ²	Kg/m
084.105.020	4074	1632	603,5	145	6882	18,58

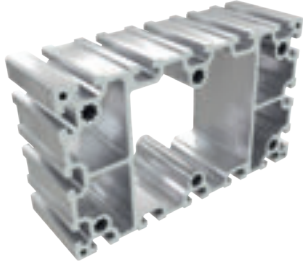

Anodised aluminium
Anodizuotas aliuminis

Natural colour
Spalva natūrali

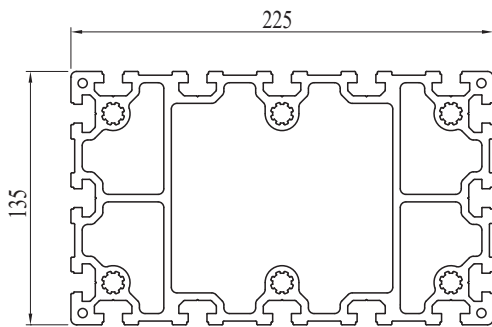

MONTAVIMAS

SISTEMI DI MONTAGGIO
SISTEMAS DE MONTAJE
SISTÉMES DE MONTAGE
MONTAGESYSTEME

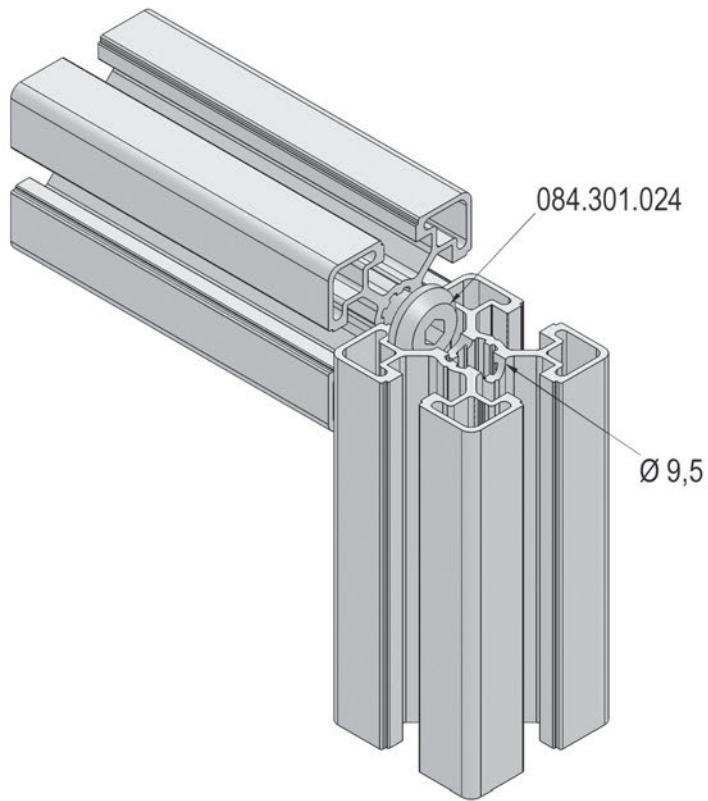



PROFILES SERIES 50 SLOT 10 BH

50 SERIJOS, 10 mm GRIOVELIO BH PROFILIAI
PERFILES SERIE 50 RANURA 10 BH
PROFILÉS SÉRIE 50 RAINURE 10 BH
PROFILE REIHE 50 NUT 10 BH

EN

Alusic series 50 profiles, featuring a 10 mm fastening T-slot, are one of the strongest ranges in the Alusic catalogue.

This range can be fastened with M8 hardware using suitable accessories, or by M12 threading at the ends of the bars. Nuts, also available in spring channel version, are available with M4, M5, M6 and M8 threads; they can be inserted at any point in the slot, even following initial assembly of the structure.

LT

„Alusic 50“ serijos profiliai su 10 mm „T“ formos tvirtinimo angomis yra vienas tvirtiausių „Alusic“ katalogo gaminių. Ši serija leidžia tvirtinti M8 varžtais, naudojant atitinkamus tvirtinimo priedus, arba per M12 sriegius strypų galuose. Veržlės, kurios taip pat yra spyruoklinės versijos, yra su M4, M5, M6 ir M8 sriegiais; jas galima įstatyti bet kurioje angos vietoje net ir po pradinio konstrukcijos surinkimo.

ES

Los perfiles Alusic serie 50, dotados de una ranura de fijación de 10 mm en “T”, conforman una de las gamas más robustas del catálogo de Alusic.

La serie permite la fijación con tornillos M8 mediante los correspondientes accesorios de fijación o mediante roscado M12 en los extremos de las barras. En lo que respecta a las tuercas, también presentes en la versión con muelle, están disponibles con roscas M4, M5, M6 y M8; pueden insertarse en cualquier punto de la ranura, incluso con posterioridad al primer montaje de la estructura.

FR

Les profilés Alusic série 50, dotés d’une rainure de fixation de 10 mm en « T », constituent une des gammes les plus robustes du catalogue Alusic.

La série permet la fixation à l’aide de vis M8, au moyen des accessoires de fixation appropriés ou par filetage M12 à l’extrémité des barres. Concernant les écrous, également présents dans la version à ressort, ils sont disponibles avec filetages M4, M5, M6 et M8 ; ils peuvent être introduits à hauteur de tout point de la rainure, y compris après le premier montage de la structure.

DE

Die Alusic-Profile der Reihe 50 mit T-förmiger Befestigungsnut zu 10 mm stellen eine der robustesten Produktreihen des Alusic-Katalogs dar.

Die Reihe ermöglicht die Befestigung mit Schrauben M8 durch das geeignete Befestigungszubehör oder durch Gewinde M12 an den Stangenenden. Die Muttern, die auch in der Ausführung mit Feder vorhanden sind, sind mit Gewinden M4, M5, M6 und M8 erhältlich; sie können an jeder Stelle der Nut auch nach der Erstmontage der Struktur eingesetzt werden.

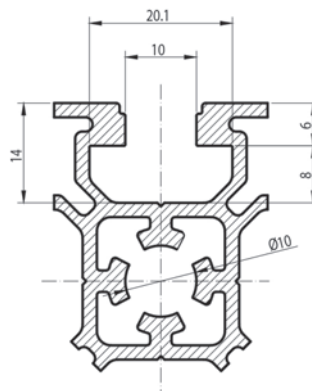

50x50, 10 mm GRIOVELIO, BH TIPO KVADRATINIAI PROFILIAI





Kodas	lx cm ⁴	ly cm ⁴	wx cm ³	wy cm ³	mm ²	Kg/m
084.109.001	21,04	21,04	8,42	8,42	865,00	2,34

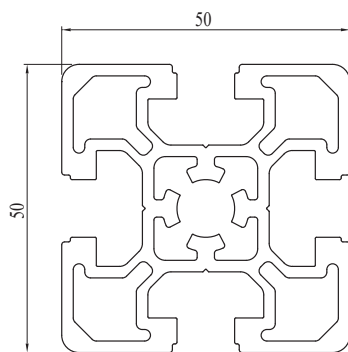

Anodised aluminium
Anodizuotas aliuminis

Natural colour
Spalva natūrali



Dangtelis - Cap - Tapòn - Embout - Abdeckkappe			
			
Kodas	Medž.	g	Sp.
084.201.055	PA	10	A
084.201.055G	PA	10	B

50x100, 10 mm GRIOVELIO, BH TIPO STAČIAKAMPIAI PROFILIAI



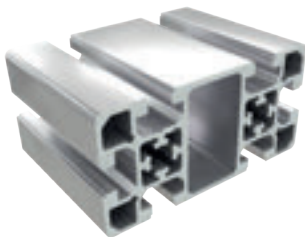

Kodas	lx cm ⁴	ly cm ⁴	wx cm ³	wy cm ³	mm ²	Kg/m
084.109.002	161,80	41,40	32,40	16,56	1606	4,34

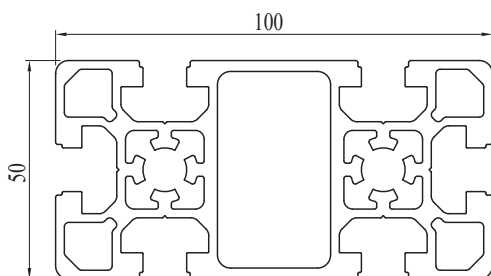

Anodised aluminium
Anodizuotas aliuminis

Natural colour
Spalva natūrali

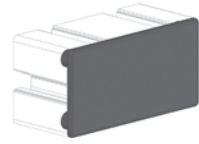

Dangtelis - Cap - Tapòn - Embout - Abdeckkappe			
			
Kodas	Medž.	g	Sp.
084.201.056	PA	20	A
084.201.056G	PA	20	B

100x100, 10 mm GRIOVELIO, BH TIPO KVADRATINIAI PROFILIAI



Kodas	Ix cm ⁴	Iy cm ⁴	wx cm ³	wy cm ³	mm ²	Kg/m
084.109.003	302,26	302,26	60,45	60,45	2832,28	7,65



Anodised aluminium
Anodizuotas aliuminis

Natural colour
Spalva natūrali

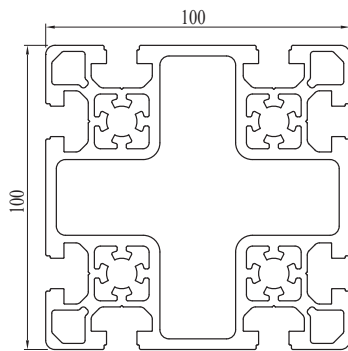

Dangtelis - Cap - Tapòn - Embout - Abdeckkappe			
Kodas	Medž.	g	Sp.
084.201.068	PA	43	A
084.201.068G	PA	43	B

MONTAVIMO SISTEMOS

SISTEMI DI MONTAGGIO
SISTEMAS DE MONTAJE
SISTÉMES DE MONTAGE
MONTAGESYSTEME

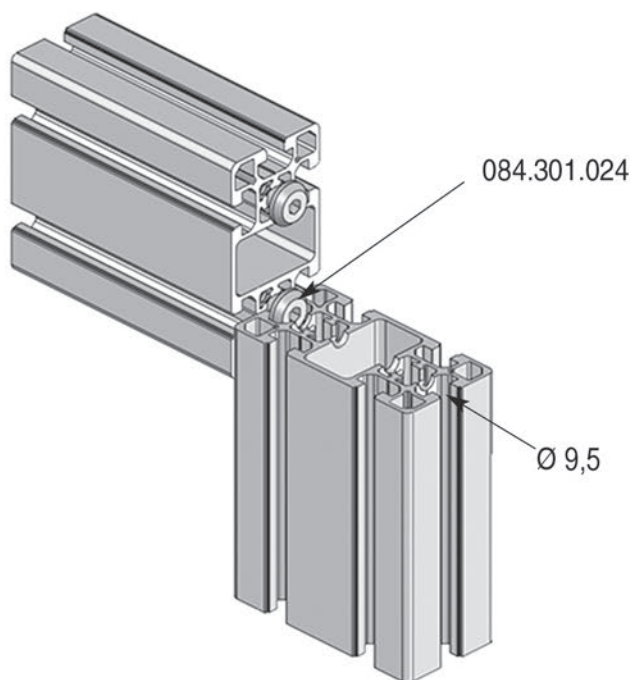
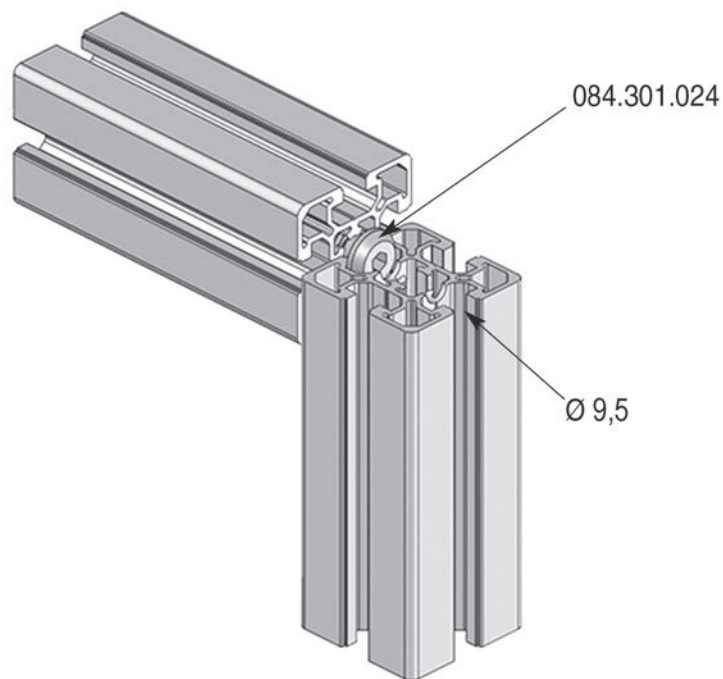





GUARD PROFILES

**APSAUGINIAI PROFILIAI
PER RECINZIONI PERFILES
PARA CERRAMIENTOS
PROFILÉS POUR CLÔTURES
PROFILE FÜR UMZÄUNUNGEN**



EN

Our guard profiles are designed with optimised characteristics, geometries and weights for the creation of machine covers and guards.

LT

Apsauginiai profiliai buvo sukurti siekiant optimizuoti mašinų dangčių ir gautų konstrukcijos charakteristikas, geometriją ir svorį.

ES

Los perfiles para cerramientos permiten optimizar las características, las geometrías y los pesos a la hora de realizar cubiertas y cercados de máquinas.

FR

Les profilés pour clôtures ont été créés afin d'optimiser les caractéristiques, les formes et les poids pour la réalisation de couvertures et de clôtures de machines.

DE

Die Profile für Umzäunungen wurden zur Optimierung der Eigenschaften, Geometrien und Gewichte für die Schaffung von Abdeckungen und Umzäunungen von Maschinen entwickelt.

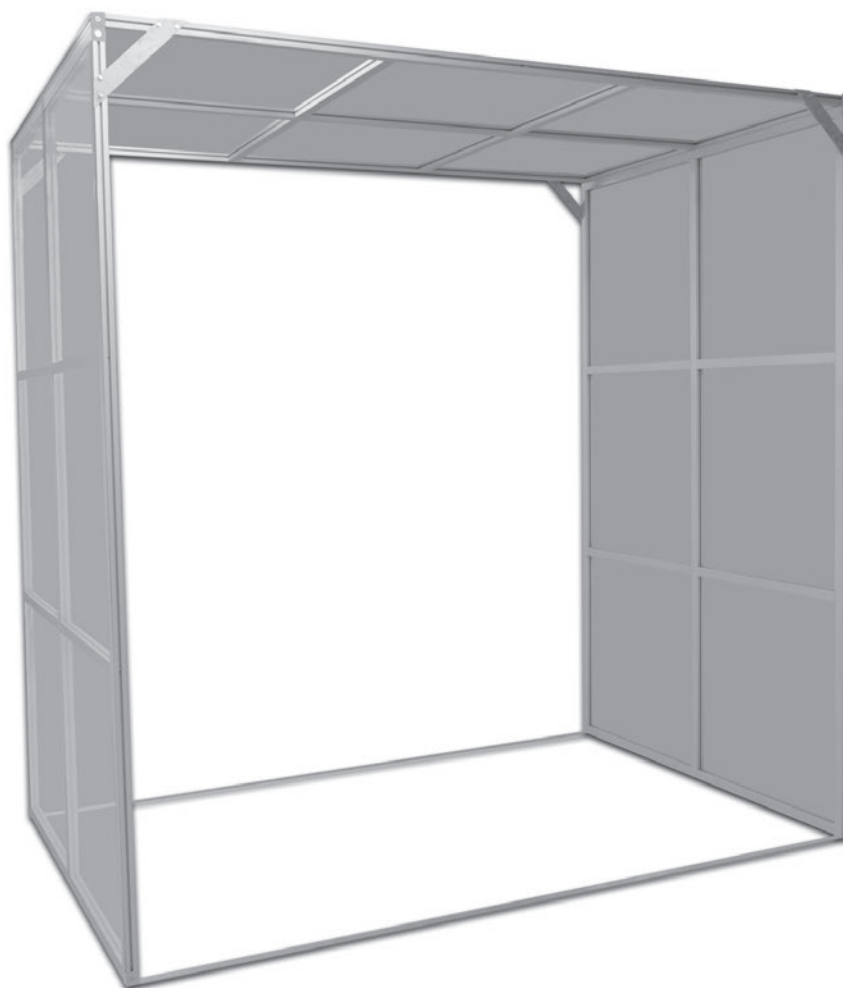



30x30 APSAUGINIAI PROFILIAI



Kodas	lx cm ⁴	ly cm ⁴	wx cm ³	wy cm ³	mm ²	Kg/m
084.104.003	2,87	3,46	1,94	2,29	339	0,92

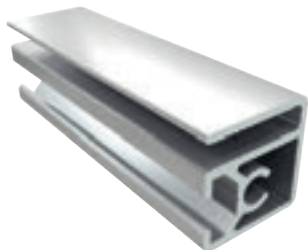

Anodised aluminium
Anodizuotas aliuminis

Natural colour
Spalva natūrali

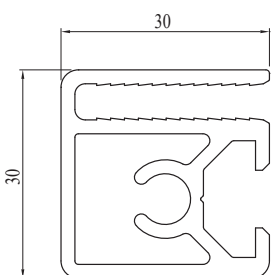

30x50 APSAUGINIAI PROFILIAI

Kodas	lx cm ⁴	ly cm ⁴	wx cm ³	wy cm ³	mm ²	Kg/m
084.112.001	6,62	4,25	2,65	2,83	360,31	0,97

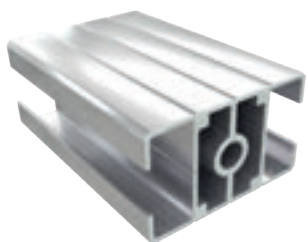

Anodised aluminium
Anodizuotas aliuminis

Natural colour
Spalva natūrali

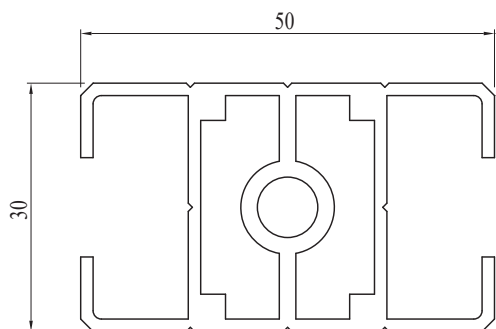

Dangtelis - Cap - Tapòn - Embout - Abdeckkappe			
Kodas	Medž.	g	Sp.
084.201.069	PA	8	A
084.201.069G	PA	9	B



50x50 APSAUGINIAI PROFILIAI

Kodas	lx cm ⁴	ly cm ⁴	wx cm ³	wy cm ³	mm ²	Kg/m
084.112.002	14,44	13,31	5,78	5,32	582,38	1,57

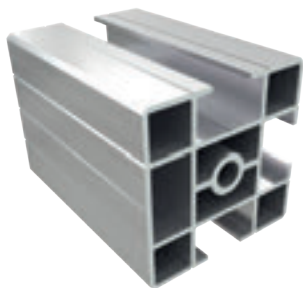

Anodised aluminium
Anodizuotas aliuminis

Natural colour
Spalva natūrali

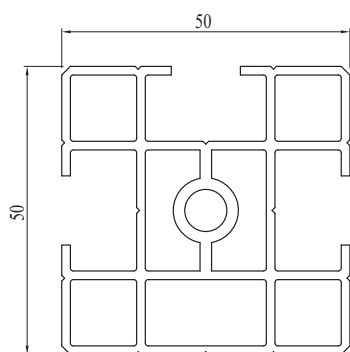

Dangtelis - Cap - Tapòn - Embout - Abdeckkappe			
Kodas	Medž.	g	Sp.
084.201.070	PA	13	A
084.201.070G	PA	13	B



Alusic

SPECIAL PROFILES

**SPECIALŪS PROFILIAI
PERFILES ESPECIALES
PROFILÉS SPÉCIAUX
SONDERPROFILE**

EN

This section contains profiles dedicated to special applications complementary to structural profiles, such as profiles for stairs or cable conduits.

LT

Šiame skyriuje surinkti profiliai, skirti specialioms reikmėms, papildančioms konstrukcinius profilius, pvz., laiptelių profiliams arba kabelių kanalams.

ES

Esta sección recoge los perfiles específicos para aplicaciones especiales complementarios a los perfiles estructurales, como los perfiles para peldaños o las canaletas para cables.

FR

Cette section rassemble les profilés destinés à des applications spéciales complémentaires aux profilés structurels, comme le profilé pour marches ou les caniveaux pour câbles.

DE

In diesem Abschnitt werden die Profile für Spezialanwendungen aufgeführt, die die Konstruktionsprofile ergänzen, wie zum Beispiel das Profil für Stufen oder Kabelkanäle.



30x30 KABELIŲ KANALAS

CANALINA PORTACAVI 30X30
 CANALETA PARA CABLES 30X30
 CANIVEAU À CÂBLES 30X30
 KABELKANAL 30X30

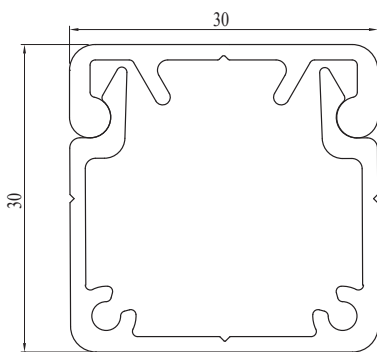
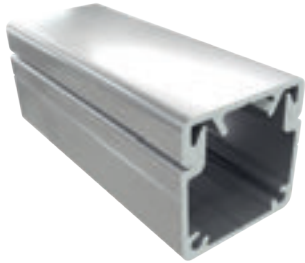

Kodas	Pastaba	Kg/m
084.101.092	Cable channel - Kabelių kanalas - Canaleta para cables - Caniveau à câbles - Abdeckung Kabelkanal	0,45
084.101.093	Cable channel cover - Kabelių kanalo dangtelis - Tapa canaleta para cables - Couvercle caniveau à câbles - Abdeckung Kabelkanal	0,28

Anodised aluminium
 Anodizuotas aliuminis

Natural colour
 Spalva natūrali

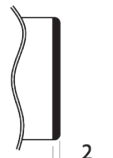
Cap - Dangtelis - Tapòn - Embout - Abdeck			
			
Kodas	Medž.	g	Sp.
084.201.096	ALL	4,7	B

40x40 KABELIŲ KANALAS

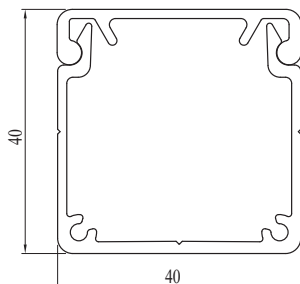
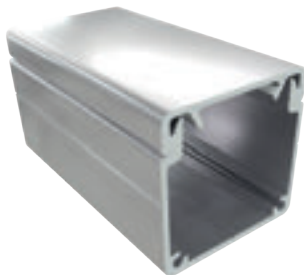

CANALINA PORTACAVI 40X40 CANALETA PARA CABLES
 40X40 CANIVEAU À CÂBLES 40X40 KABELKANAL 40X40



Kodas	Pastaba	Kg/m
084.101.097	Cable channel - Kabelių kanalas - Canaleta para cables - Caniveau à câbles - Abdeckung Kabelkanal	0,6
084.101.098	Cable channel cover - Kabelių kanalo dangtelis - Tapa canaleta para cables - Couvercle caniveau à câbles - Abdeckung Kabelkanal	0,31

Anodised aluminium
 Anodizuotas aliuminis

Natural colour
 Spalva natūrali

Cap - Dangtelis - Tapòn - Embout - Abdeck			
			
Kodas	Medž.	g	Sp.
084.201.097	ALL	8,5	B

40X80 STAČIAKAMPIS KABELIŲ KANALAS

CANALINA PORTAČAVI 40X80 CANALETA PARA CABLES
40X80 CANIVEAU À CÂBLES 40X80 KABELKANAL 40X80

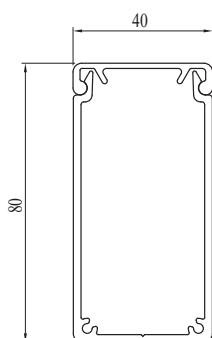

NEW

Kodas	Pastaba	Kg/m
084.101.102	Cable channel - Kabelių kanalas - Canaleta para cables - Caniveau à câbles - Abdeckung Kabelkanal	1,19
084.101.098	Cable channel cover - Kabelių kanalo dangtelis - Tapa canaleta para cables - Couvercle caniveau à câbles - Abdeckung Kabelkanal	0,3

Anodised aluminium
Anodizuotas aliuminis

Natural colour
Spalva natūrali

Cap - Dangtelis - Tapòn - Embout - Abdeck			
Kodas	Medž.	g	Sp.
084.201.102	ALL	17	B

45x45 KVADRATINIS KABELIŲ KANALAS

CANALINA PORTAČAVI 45X45 CANALETA PARA CABLES
45X45 CANIVEAU À CÂBLES 45X45 KABELKANAL 45X45

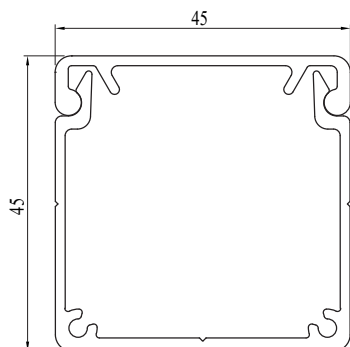

Kodas	Pastaba	Kg/m
084.101.053	Cable channel - Kabelių kanalas - Canaleta para cables - Caniveau à câbles - Abdeckung Kabelkanal	0,70
084.101.054	Cable channel cover - Kabelių kanalo dangtelis - Tapa canaleta para cables - Couvercle caniveau à câbles - Abdeckung Kabelkanal	0,40

Anodised aluminium
Anodizuotas aliuminis

Natural colour
Spalva natūrali

Cap - Dangtelis - Tapòn - Embout - Abdeck			
Kodas	Medž.	g	Sp.
084.201.053	ALL	15	B



60x60 KVADRATINIS KABELIŲ KANALAS

CANALINA PORTACAVI 60X60 CANALETA PARA CABLES 60X60
CANIVEAU À CÂBLES 60X60 KABELKANAL 60X60

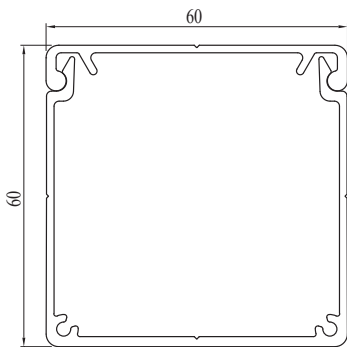

Kodas	Pastaba	Kg/m
084.101.078	Cable channel - Kabelių kanalas - Canaleta para cables - Caniveau à câbles - Abdeckung Kabelkanal	0,87
084.101.079	Cable channel cover - Kabelių kanalo dangtelis - Tapa canaleta para cables - Couvercle caniveau à câbles - Abdeckung Kabelkanal	0,39

Anodised aluminium
Anodizuotas aliuminis

Natural colour
Spalva natūrali

Cap - Dangtelis - Tapòn - Embout - Abdeck			
Kodas	Medž.	g	Sp.
084.201.079	ALL	19	B

80x40 STAČIAKAMPIS KABELIŲ KANALAS

CANALINA PORTACAVI 80X40 CANALETA PARA CABLES 80X40
CANIVEAU À CÂBLES 80X40 KABELKANAL 80X40

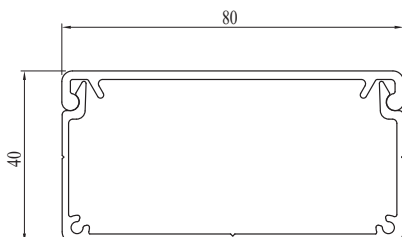
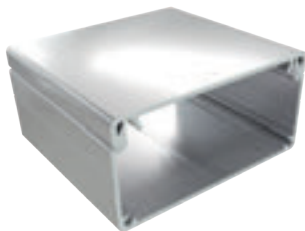

NEW

Kodas	Pastaba	Kg/m
084.101.101	Cable channel - Kabelių kanalas - Canaleta para cables - Caniveau à câbles - Kabelkanal	0,81
084.101.056	Cable channel cover - Kabelių kanalo dangtelis - Tapa canaleta para cables - Couvercle caniveau à câbles - Abdeckung Kabelkanal	0,6

Anodised aluminium
Anodizuotas aliuminis

Natural colour
Spalva natūrali

Dangtelis - Cap - Tapòn - Embout - Abdeckkappe			
Kodas	Medž.	g	Sp.
084.201.101	ALL	17	B

80x80 KVADRATINIS KABELIŲ KANALAS

CANALINA PORTACAVI 80X80 CANALETA PARA CABLES
80X80 CANIVEAU À CÂBLES 80X80 KABELKANAL 80X80

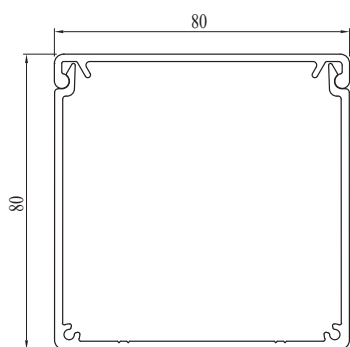

Kodas	Pastaba	Kg/m
084.101.055	Cable channel - Kabelių kanalas - Canaleta para cables - Caniveau à câbles - Abdeckung Kabelkanal	1,50
084.101.056	Cable channel cover - Kabelių kanalo dangtelis - Tapa canaleta para cables - Couvercle caniveau à câbles - Abdeckung Kabelkanal	0,60

Anodised aluminium
Anodizuotas aliuminis

Natural colour
Spalva natūrali

Cap - Dangtelis - Tapòn - Embout - Abdeck			
Kodas	Medž.	g	Sp.
084.201.059	ALL	30	B

120x80 STAČIAKAMPIS KABELIŲ KANALAS

CANALINA PORTACAVI 120X80 CANALETA PARA
CABLES 120X80 CANIVEAU À CÂBLES 120X80
KABELKANAL 120X80

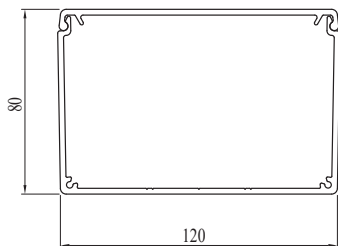
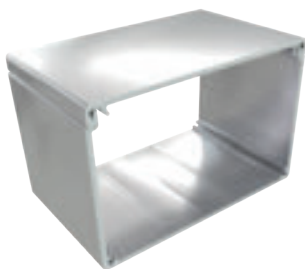

Kodas	Pastaba	Kg/m
084.101.099	Cable channel - Kabelių kanalas - Canaleta para cables - Caniveau à câbles - Abdeckung Kabelkanal	1,86
084.101.100	Cable channel cover - Kabelių kanalo dangtelis - Tapa canaleta para cables - Couvercle caniveau à câbles - Abdeckung Kabelkanal	0,95

Anodised aluminium
Anodizuotas aliuminis

Natural colour
Spalva natūrali

Cap - Dangtelis - Tapòn - Embout - Abdeck			
Kodas	Medž.	g	Sp.
084.201.099	ALL	51,8	B



100x150 STAČIAKAMPIS KABELIŲ KANALAS

NEW

CANALINA PORTAČA VI 100X150 CANALETA PARA CABLES
100X150 CANIVEAU À CÂBLES 100X150 KABELKANAL 100X150

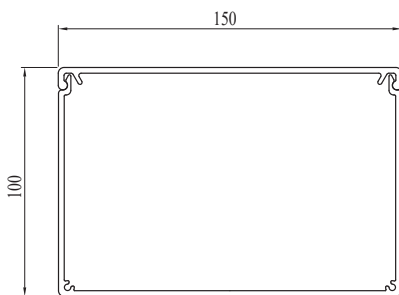

Kodas	Pastaba	Kg/m
084.101.104	Cable channel - Kabelių kanalas - Canaleta para cables - Caniveau à câbles - Abdeckung Kabelkanal	2,32
084.101.105	Cable channel cover - Kabelių kanalo dangtelis - Tapa canaleta para cables - Couvercle caniveau à câbles - Abdeckung Kabelkanal	1,18

Anodised aluminium
Anodizuotas aliuminis

Natural colour
Spalva natūrali

Cap - Dangtelis - Tapòn - Embout - Abdeck			
Kodas	Medž.	g	Sp.
084.201.103	ALL	51,8	B





Alusic

ACCESSORIES

PRIEDAI
ACCESORIOS
ACCESSOIRES
ZUBEHÖR



LT

„Alusic“ – tai didžiulis specialiai aliuminio profiliams sukurtų priedų asortimentas. Kruopštaus projektavimo proceso rezultatas, išbandytas naudojant greito prototipų kūrimo technologijas, todėl mūsų priedai suderinami su dauguma rinkoje esančių aliuminio profilių. Šiame skyriuje rasite galinius dangtelius, uždarymo juosteles, tvirtinimo detales, vidines ir išorines jungtis, pagrindus, ratukus, vyrius, rankenas ir slankiklių bei apsauginių elementų komponentus..

IT

Alusic significa una vasta gamma di accessori studiati per i profili in alluminio. Frutto di un'attenta progettazione e testati con l'ausilio delle tecniche di prototipazione rapida, gli accessori sono compatibili con la maggior parte dei profili in alluminio presenti sul mercato.

In questa sezione possiamo trovare tappi di chiusura, chiudicava, viteria, giunti interni ed esterni, basi di ancoraggio, ruote, cerniere, maniglie ed elementi per scorrevoli e per la realizzazione di protezioni.

ES

Alusic ofrece una extensa gama de accesorios específicamente estudiados para los perfiles de aluminio. Fruto de un atento diseño y probados mediante técnicas de creación rápida de prototipos, los accesorios son compatibles con la mayoría de los perfiles de aluminio presentes en el mercado.

En esta sección encontrará tapones de cierre, taparranuras, tornillería, juntas internas y externas, bases de anclaje, ruedas, bisagras, asideros y elementos para correderas y para la realización de protecciones.

FR

Alusic est synonyme de vaste gamme d'accessoires étudiés pour les profilés en aluminium. Fruit d'une minutieuse conception et testés au moyen de techniques permettant la création rapide de prototypes, les accessoires sont compatibles avec la plupart des profilés en aluminium présents sur le marché.

La présente section contient des bouchons de fermeture, des fermetures de rainure, de la visserie, des joints internes et externes, des bases d'ancrage, des roues, des charnières, des poignées et des éléments pour coulissants et pour la réalisation de protections.

DE

Alusic bietet eine große Auswahl an Zubehör für Aluminiumprofile. Das Zubehör, das sorgsam entwickelt und mithilfe der Rapid-Prototyping-Techniken getestet wurde, ist mit den meisten auf dem Markt erhältlichen Aluminiumprofilen kompatibel.

In diesem Abschnitt finden wir Verschlusskappen, Verschleißelemente für Nuten, Schrauben, innere und äußere Verbinder, Befestigungssockel, Räder, Scharniere, Griffe und Elemente für Schiebekonstruktionen und für die Schaffung von Schutzvorrichtungen.



PROFILIO DANGTELIS

CHIUDICAVA RIGIDO
TA PA-RANURA
PROFILÉ DE
RECOUVREMENT
ABDECKPROFIL

Kodas	Pastaba	g/m
084.203.023	L = 2000 mm	30



Rigid black PVC
Juodas kietas PVC
PVC rígido color negro
PVC rigide noir Hart-
PVC schwarz

Other colours on request
Kitos spalvos pagal pageidavimą
Otros colores bajo solicitud
Autres couleurs sur demande
Weitere Farben auf Anfrage

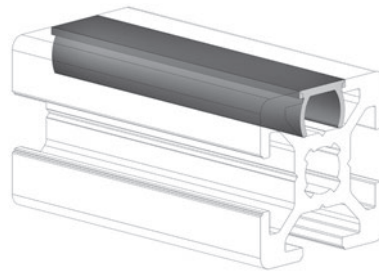
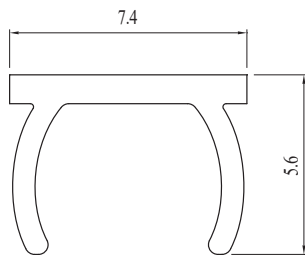

PROFILIO DANGTELIS

CHIUDICAVA RIGIDO
TA PA-RANURA
PROFILÉ DE RECOUVREMENT
ABDECKPROFIL

Kodas	Pastaba	g/m
084.203.024	L = 2000 mm	40



Rigid black PVC
Juodas kietas PVC
PVC rígido color negro
PVC rigide noir Hart-
PVC schwarz

Other colours on request
Kitos spalvos pagal pageidavimą
Otros colores bajo solicitud
Autres couleurs sur demande
Weitere Farben auf Anfrage

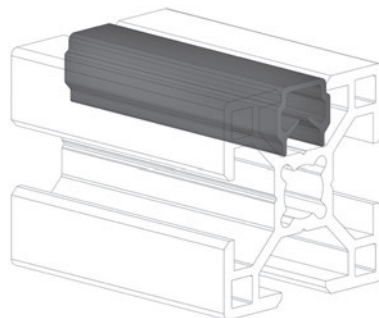
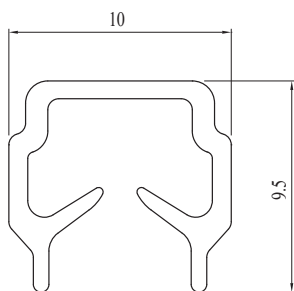



PROFILIO DANGTELIS

CHIUDICAVA MORBIDO TA PA-RANURA
PROFILÉ DE RECOUVREMENT ABDECKPROFIL

Kodas	Pastaba	Spalva	g/m
084.203.010	50 m rolls - ritinys 50 m - rollos de 50 m - rouleaux 50 m - Rollen 50 m	B	60
084.203.010N	50 m rolls - ritinys 50 m - rollos de 50 m - rouleaux 50 m - Rollen 50 m	B	60



Soft PVC
Minkštas PVC
PVC flexible
PVC souple
Weich-PVC

Other colours on request
Kitos spalvos pagal pageidavimą
Otros colores bajo solicitud
Autres couleurs sur demande
Weitere Farben auf Anfrage

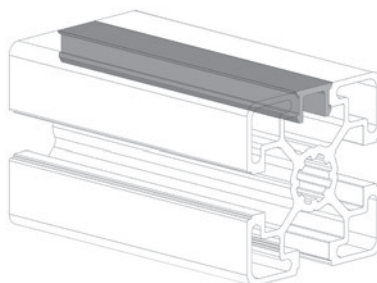
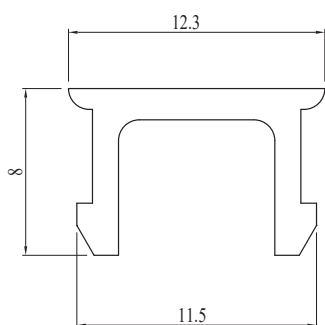

PROFILIO DANGTELIS

CHIUDICAVA RIGIDO
TA PA-RANURA
PROFILÉ DE RECOUVREMENT ABDECKPROFIL

Kodas	Pastaba	Spalva	g/m
084.203.026	L = 2000 mm	B	60
084.203.027	L = 2000 mm	B	60

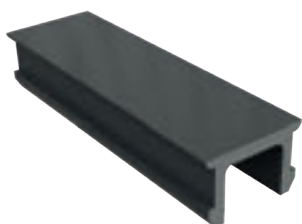

Rigid PVC
Kietas PVC
PVC rigido
PVC rigide
Hart-PVC

Other colours on request
Kitos spalvos pagal pageidavimą
Otros colores bajo solicitud
Autres couleurs sur demande
Weitere Farben auf Anfrage

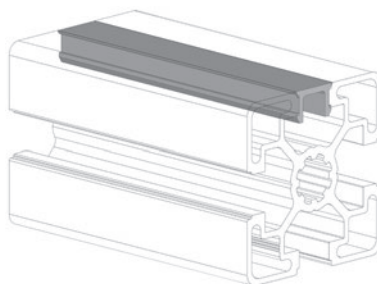
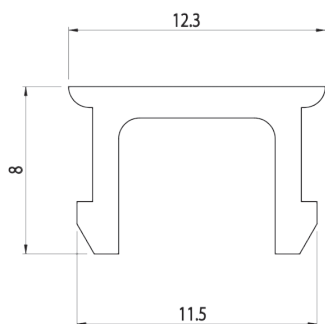



VARŽTAS CILINDRINE GALVA

VITI CILINDRICHE
TORNILLOS DE CABEZA CILÍNDRICA VIS À
TÊTE CYLINDRIQUE
ZYLINDERKOPFSCHRAUBEN

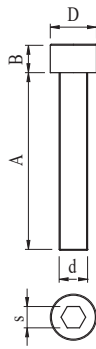

Kodas	Pastaba	d	A	D	B	s	g
084.301.008	M4x12	M4	12	7	2,5	2,5	1
084.301.054	M5x8	M5	8	8,50	3,50	3	2
084.301.009	M5x12	M5	12	8	3,50	3	3
084.301.035	M5x16	M5	16	8	3,50	3	3
084.301.036	M5x20	M5	20	8	3,50	3	4
084.301.010	M6x12	M6	12	10	4	4	4
084.301.011	M6x16	M6	16	10	4	4	5
084.301.001	M6x20	M6	20	10	4	4	6
084.301.002	M8x16	M8	16	13	5	5	8
084.301.003	M8x20	M8	20	13	5	5	10
084.301.012	M8x22	M8	22	13	5	5	12
084.301.004	M8x25	M8	25	13	5	5	12
084.301.038	M8x30	M8	30	13	5	5	15
084.301.013	M8x35	M8	35	13	5	5	18
084.301.005	M8x40	M8	40	13	5	5	18
084.301.006	M8x50	M8	50	13	5	5	20
084.301.007	M8x60	M8	60	13	5	5	24

Galvanised steel
Cinkuotas plienas
Acero galvanizado
Acier zingué
Verzinkter Stahl



VARŽTAS CILINDRINE GALVA

STAINLESS STEEL

VITI CILINDRICHE
 TORNILLOS DE CABEZA CILÍNDRICA VIS
 À TÊTE CYLINDRIQUE
 ZYLINDERKOPFSCHRAUBEN

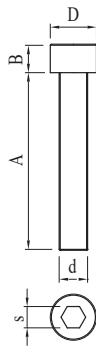

Kodas	Pastaba	d	A	D	B	s	g
084.301.032	M8x12	M8	12	13	8	6	8
084.301.034	M8x16	M8	16	13	5	5	9
084.301.029	M8x16	M8	16	13	8	6	11
084.301.025	M8x20	M8	20	13	8	6	13
084.301.033	M8x25	M8	25	13	8	6	15
084.301.031	M8x30	M8	30	13	8	6	16
084.301.026	M8x35	M8	35	13	8	6	17
084.301.027	M8x40	M8	40	13	8	6	20
084.301.030	M8x45	M8	45	13	8	6	21
084.301.028	M8x50	M8	50	13	8	6	22

Stainless steel
 Nerūdijantis plienas
 Acero inoxidable
 Acier inox
 Rostfreier Stahl



VARŽTAS SU ĮDUBA ŠEŠIAKAMPIUI

VITI BOMBATE
TORNILLOS DE CABEZA ABOMBADA
VIS À TÊTE BOMBÉE
LINSENSCHRAUBEN



Kodas	Pastaba	d	A	D	B	s	g
084.301.079	M5x12	M5	12	10	-	-	3
084.301.040	M6x16	M6	16	10	-	-	5
084.301.039	M8x20	M8	20	14	-	-	6

Galvanised steel
Cinkuotas plienas
Acero galvanizado
Acier zingué
Verzinkter Stahl

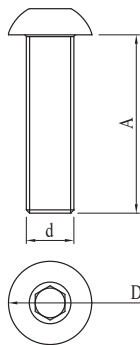

M12x30 VARŽTAS SU ĮDUBA ŠEŠIAKAMPIUI

VITE BOMBATA
TORNILLO DE CABEZA ABOMBADA
VIS À TÊTE BOMBÉE
LINSENSCHRAUBE

BH L 10 45 BH H 10 45 BH 10 50



Kodas	Pastaba	g
084.301.024	M12x30	45

Galvanised steel
Cinkuotas plienas
Acero galvanizado
Acier zingué
Verzinkter Stahl

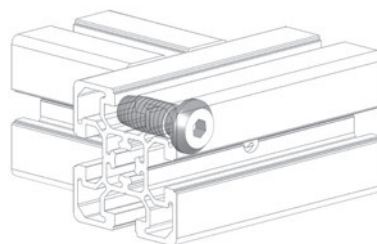
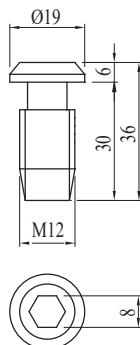



S12x30 SAVISRIEGIS VARŽTAS

VITE AUTOFILETTANTE
TORNILLO AUTORROSCANTE
VIS TARAUEUSE
GEWINDESCHNEIDENDE SCHRAUBE



Kodas	Pastaba	g
084.301.037	S12x30	25



Galvanised steel
Cinkuotas plienas
Acero galvanizado
Acier zingué
Verzinkter Stahl

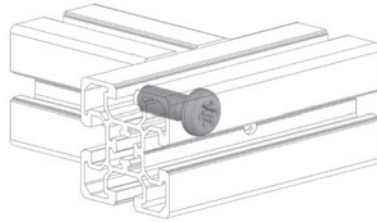

T VARŽTAS

VITI A MARTELLO
TORNILLOS EN T
VIS À TÊTE
MARTEAU
TBOLZEN



Kodas	Pastaba	d	A	D	B	s	g
084.301.041	M6x12	M6	12				8
084.301.042	M6x16	M6	16				9
084.301.043	M6x20	M6	20				10
084.301.044	M6x25	M6	25				11



Galvanised steel
Cinkuotas plienas
Acero galvanizado
Acier zingué
Verzinkter Stahl

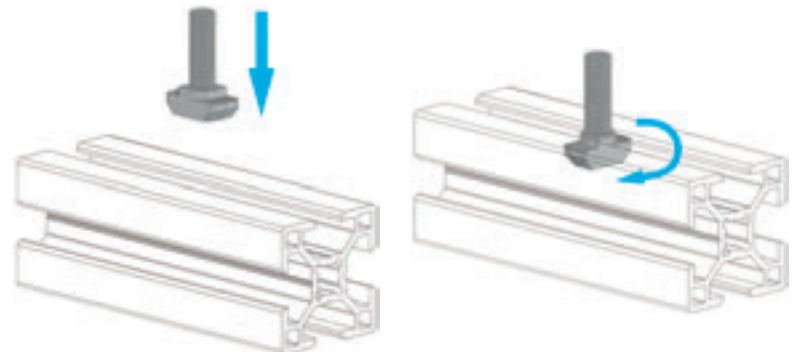
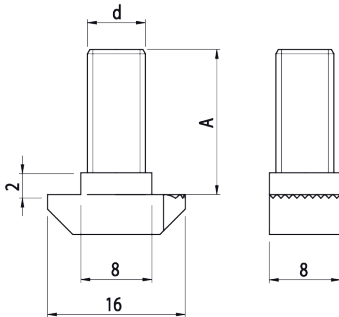



T VARŽTAS

VITI A MARTELO
TORNILLOS EN T
VIS À TÊTE
MARTEAU
TBOLZEN



BH 10 L 40 BH L 10 L 45 BH H 10 H 45 BH 10 L 50

Kodas	Pastaba	d	A	D	B	s	g
084.301.018	M8x20	M8	20				13
084.301.019	M8x25	M8	25				15
084.301.020	M8x30	M8	30				16
084.301.045	M8x35	M8	35				18
084.301.021	M8x40	M8	40				20

Galvanised steel
Cinkuotas plienas
Acero galvanizado
Acier zingué
Verzinkter Stahl

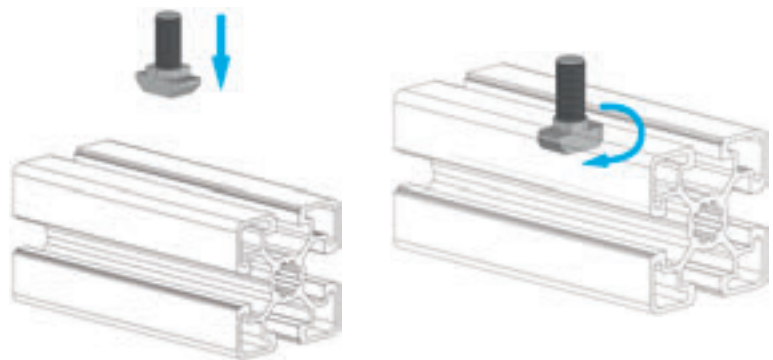
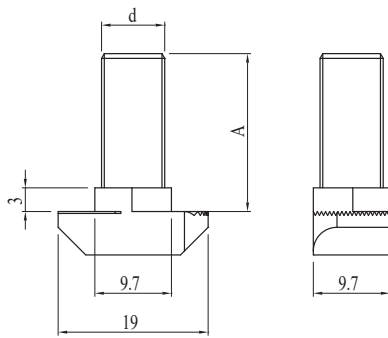



T VARŽTAS

VITI A MARTELLO
TORNILLOS EN T
VIS À TÊTE MARTEAU
TBOLZEN

STAINLESS STEEL

BH 10 40 BH L 10 45 BH H 10 45 BH 10 50

Kodas	Pastaba	d	A	D	B	s	g
084.301.046	M8x20	M8	20				13
084.301.047	M8x25	M8	25				15



Stainless steel
Nerūdijantis plienas
Acero inoxidable
Acier inox
Rostfreier Stahl

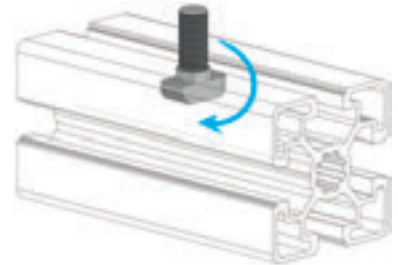
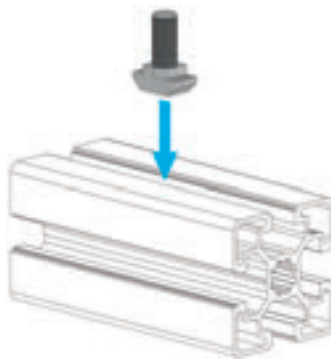
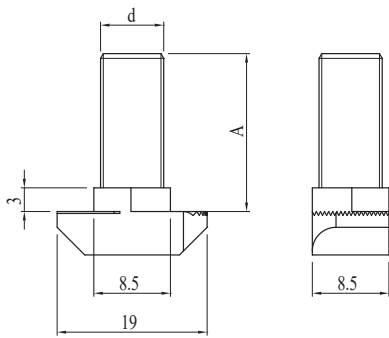

**T VERŽLĖ**

DADO A MARTELLO
TUERCA EN T
ÉCROU À TÊTE
MARTEAU
HAMMERMUTTER

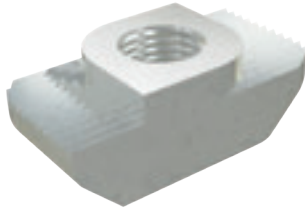

Kodas	Pastaba	g
084.302.021	M4	1
084.302.061	M5	1

Galvanised steel
Cinkuotas plienas
Acero galvanizado
Acier zingué
Verzinkter Stahl

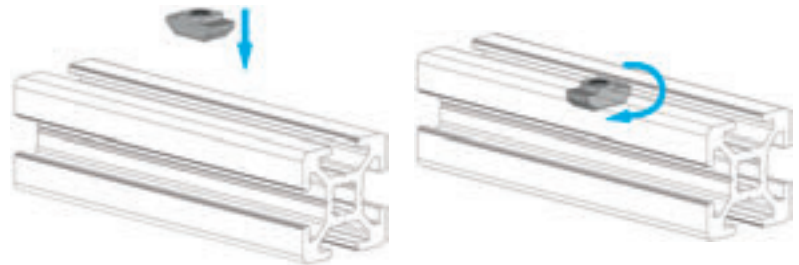
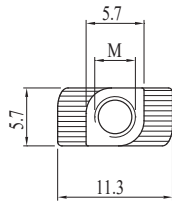
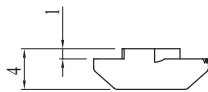
**T VERŽLĖ**

DADO A MARTELLO
TUERCA EN T
ÉCROU À TÊTE
MARTEAU
HAMMERMUTTER

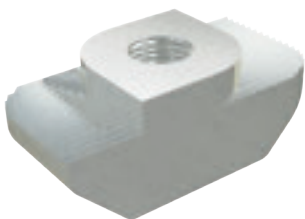

Kodas	Pastaba	g
084.302.022	M4	4
084.302.023	M5	3,5
084.302.024	M6	3

Galvanised steel
Cinkuotas plienas
Acero galvanizado
Acier zingué
Verzinkter Stahl

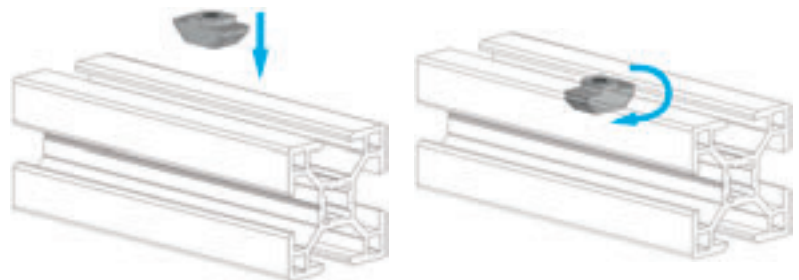
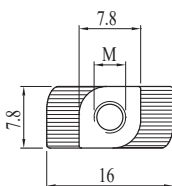
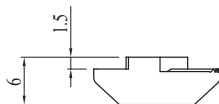



T VERŽLĖ

STAINLESS STEEL

BH 8 30

DADO A MARTELLO
TUERCA EN T
ÉCROU À TÊTE
MARTEAU
HAMMERMUTTER



Kodas	Pastaba	g
084.302.062	M4	1
084.302.063	M5	1
084.302.064	M6	1

Stainless steel
Nerūdijantis plienas
Acero inoxidable
Acier inox
Rostfreier Stahl

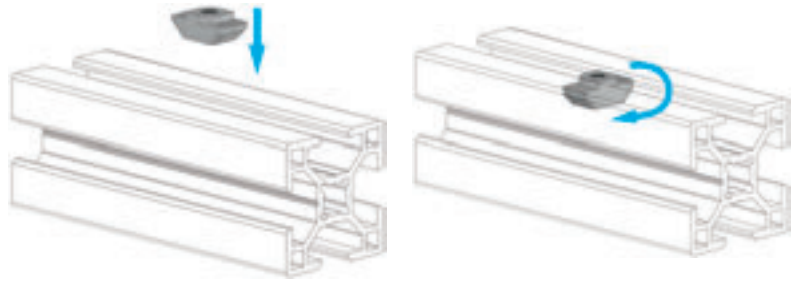
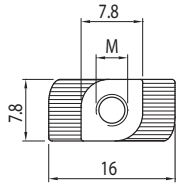
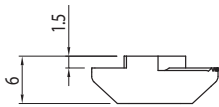

T VERŽLĖ

BH 10 40 BH L 10 45 BH H 10 45 BH 10 50

DADO A MARTELLO
TUERCA EN T
ÉCROU À TÊTE
MARTEAU
HAMMERMUTTER

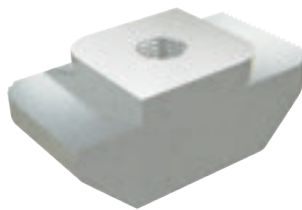

Kodas	Pastaba	g
084.302.025	M4	2
084.302.026	M5	2
084.302.027	M6	2
084.302.028	M8	1

Galvanised steel
Cinkuotas plienas
Acero galvanizado
Acier zingué
Verzinkter Stahl

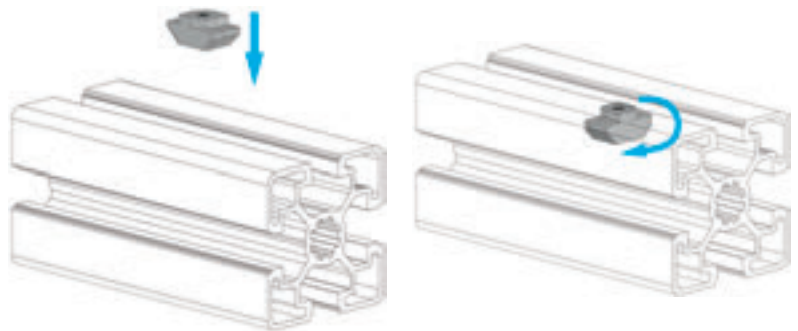
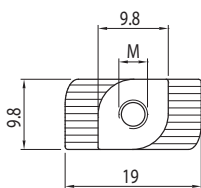
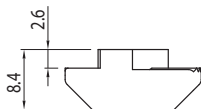

**T VERŽLĖ**

DADO A MARTELLO
TUERCA EN T
ÉCROU À TÊTE
MARTEAU
HAMMERMUTTER

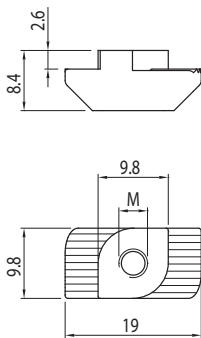
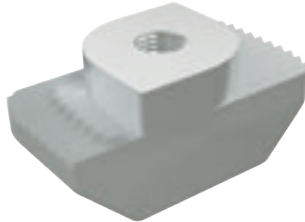

STAINLESS STEEL

BH 10 40
BH 10 45
BH 10 45
BH 10 50

Kodas	Pastaba	g
084.302.065	M4	1
084.302.066	M5	1
084.302.067	M6	1
084.302.029	M8	1

Stainless steel
Nerūdijantis plienas
Acero inoxidable
Acier inox Rostfreier
Stahl

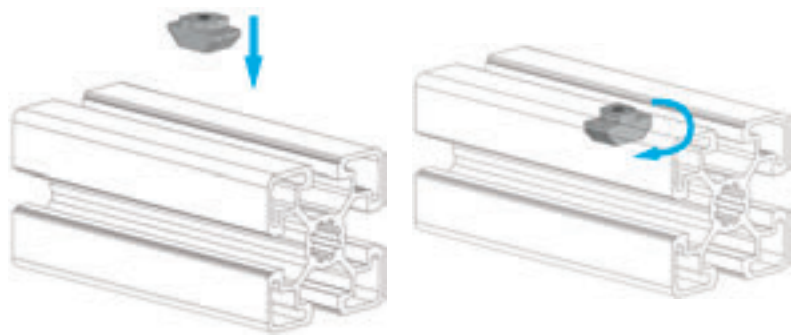
**STUMDOMASIS BLOKAS**

DADO CON RISALTO
TUERCA EN T
ÉCROU EN T
NUTENSTEIN

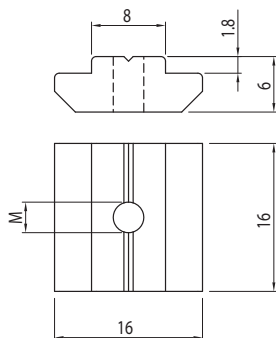
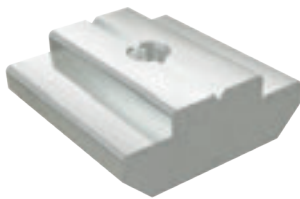

NEW

BH 8 30

Kodas	Pastaba	g
084.302.095	M4	20
084.302.096	M5	19
084.302.097	M6	18
084.302.098	M8	17

Galvanised steel
Cinkuotas plienas
Acero galvanizado
Acier zingué
Verzinkter Stahl

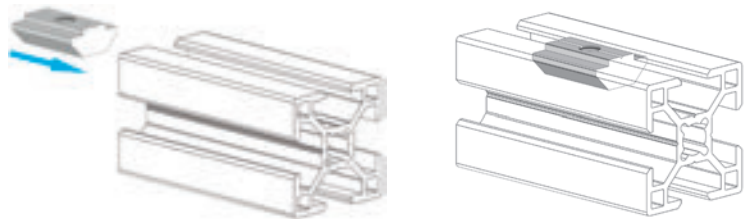



STUMDOMASIS BLOKAS-VERŽLĖ

DADO CON RISALTO
TUERCA EN T
ÉCROU EN T
NUTENSTEIN

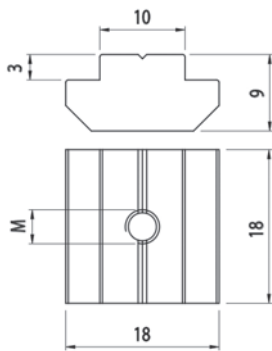
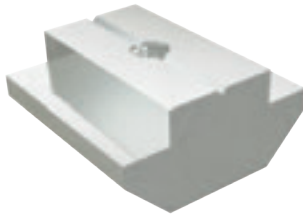

Kodas	Pastaba	g
084.302.069	M4	22
084.302.070	M5	21
084.302.071	M6	20
084.302.072	M8	19

Galvanised steel
Cinkuotas plienas
Acero galvanizado
Acier zingué
Verzinkter Stahl

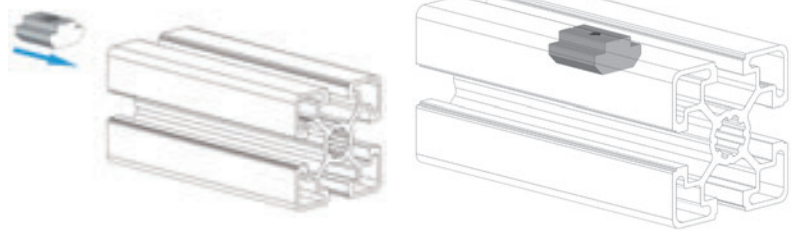

STUMDOMASIS BLOKAS-VERŽLĖ

DADO CON RISALTO TUERCA EN T ÉCROU EN T
NUTENSTEIN

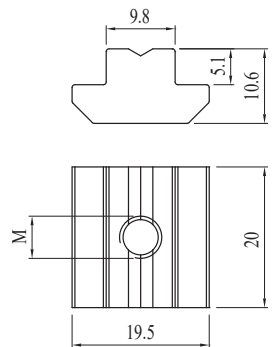
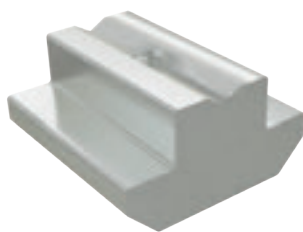

Kodas	Pastaba	g
084.302.043	M4	22
084.302.044	M5	21
084.302.045	M6	20
084.302.046	M8	19

Galvanised steel
Cinkuotas plienas
Acero galvanizado
Acier zingué
Verzinkter Stahl

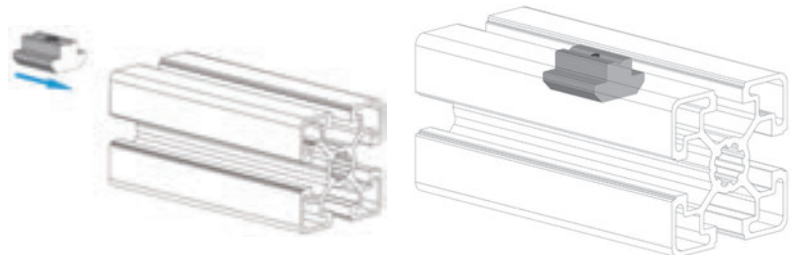



ĮSUKAMAS STUMDOMAS BLOKAS-VERŽLĖ SU SPYRUOKLE

DADO CON RISALTO E MOLLA
TUERCA CON MUELLE
ÉCROU À RESSORT
NUTENSTEIN MIT FEDERBLECH



Kodas	Pastaba	g
084.302.119	M4	18
084.302.120	M5	17
084.302.121	M6	17
084.302.122	M8	16

Galvanised steel
Cinkuotas plienas
Acero galvanizado
Acier zingué
Verzinkter Stahl

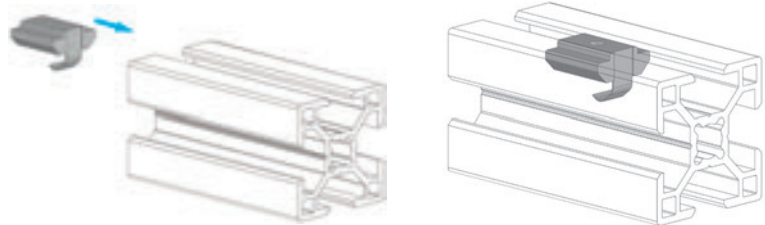
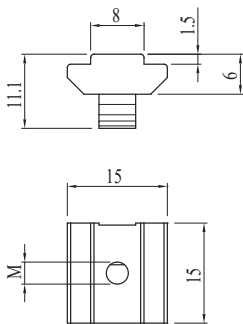

ĮSUKAMAS STUMDOMAS BLOKAS-VERŽLĖ SU SPYRUOKLE

DADO CON RISALTO E MOLLA
TUERCA CON MUELLE
ÉCROU À RESSORT
NUTENSTEIN MIT FEDERBLECH



Kodas	Pastaba	g
084.302.099	M4	21
084.302.100	M5	20
084.302.101	M6	20
084.302.102	M8	19
084.302.103	M10	18

Galvanised steel
Cinkuotas plienas
Acero galvanizado
Acier zingué
Verzinkter Stahl

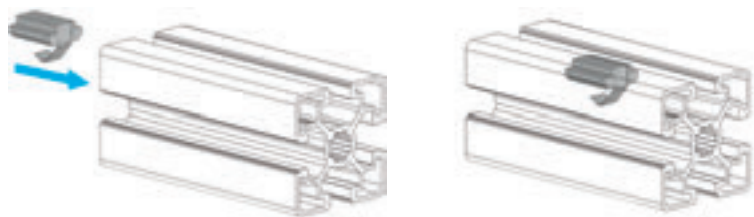
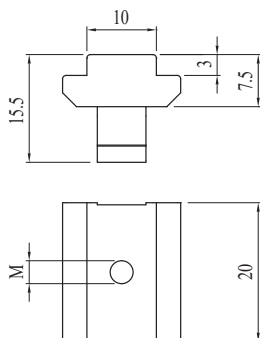

**ĮSUKAMAS STUMDOMAS BLOKAS-VERŽLĖ SU SPYRUOKLE**BH
8
30

DADO CON RISALTO E MOLLA
TUERCA CON MUELLE
ÉCROU À RESSORT
NUTENSTEIN MIT FEDERBLECH

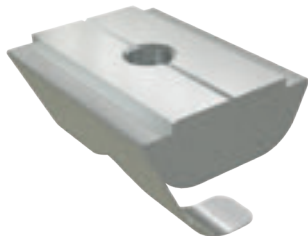

Kodas	Pastaba	g
084.302.115	M4	8
084.302.116	M5	8
084.302.117	M6	7
084.302.118	M8	6

Galvanised steel
Cinkuotas plienas
Acero galvanizado
Acier zingué
Verzinkter Stahl

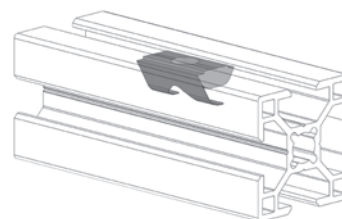
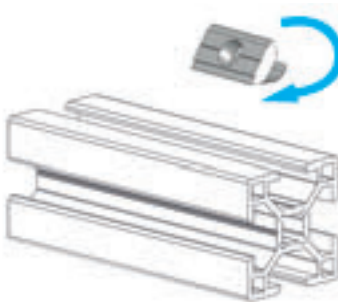
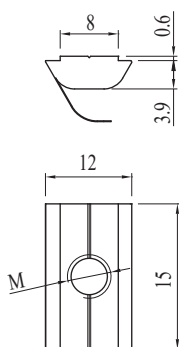
**ĮSUKAMAS STUMDOMAS BLOKAS-VERŽLĖ SU SPYRUOKLE**BH
10
40BH
10
45BH
10
45BH
10
50

DADO CON RISALTO E MOLLA
TUERCA CON MUELLE
ÉCROU À RESSORT
NUTENSTEIN MIT FEDERBLECH



Kodas	Pastaba	g
084.302.081	M4	11
084.302.082	M5	10
084.302.083	M6	9
084.302.084	M8	8

Galvanised steel
Cinkuotas plienas
Acero galvanizado
Acier zingué
Verzinkter Stahl

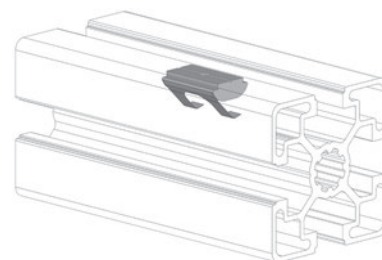
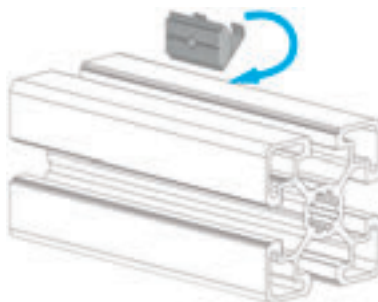
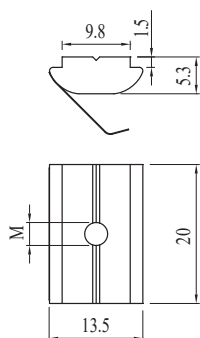



ĮSUKAMA VERŽLĖ SU RUTULIUKU

DADO A CULLA CON SFERA
 TUERCA EN FORMA DE CUNA CON BOLA ÉCROU À
 BERCEAU AVEC SPHÈRE WIEGENFÖRMIGE MUTTER MIT
 KUGEL

Kodas	Pastaba	g
084.302.127	M4	2
084.302.128	M5	2



Galvanised steel
 Cinkuotas plienas
 Acero galvanizado
 Acier zingué
 Verzinkter Stahl

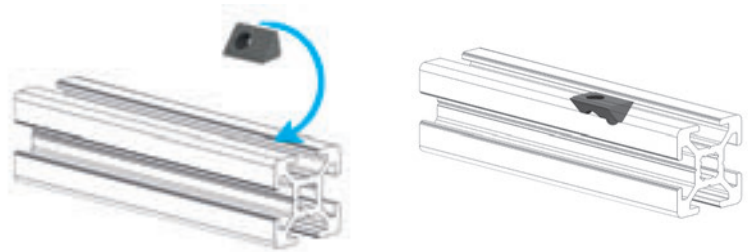
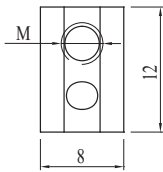
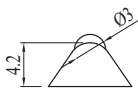

FLANŠINĖ VERŽLĖ

DADO FLANGIATO TUERCA CON
 COLLAR ÉCROU À BRIDE
 FLANSCHMUTTER

Kodas	Pastaba	g
084.302.036	M8	2



Galvanised steel
 Cinkuotas plienas
 Acero galvanizado
 Acier zingué
 Verzinkter Stahl

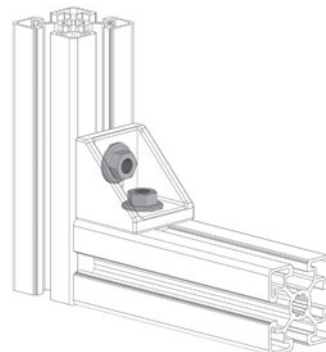
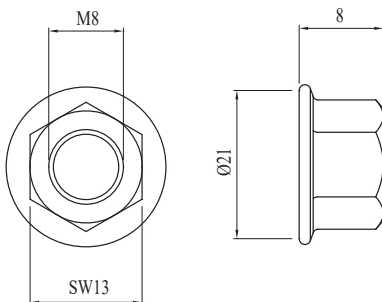



IVORĖ

BOCCOLA
CASQUILLO
DOUILLE
BUCHSE

BH 10 40 BH L 10 45 BH H 10 45 BH 10 50

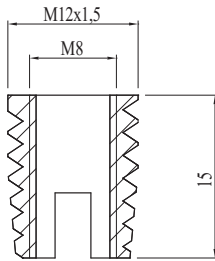

Kodas	Pastaba	g
084.312.003	M12/M8	18

Galvanised steel
Cinkuotas plienas
Acero galvanizado
Acier zingué
Verzinkter Stahl

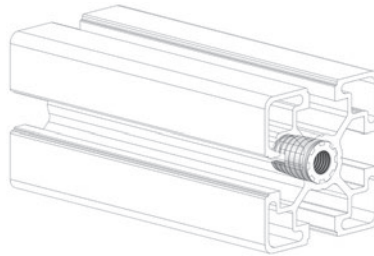

SAVISRIEGĖ IVORĖ

BOCCOLA AUTOFILETTANTE CASQUILLO
AUTORROSCANTE
DOUILLE AUTO-TARAUDEUSE
SELBSTSCHNEIDENDER GEWINDEINSATZ

BH 10 40 BH L 10 45 BH H 10 45 BH 10 50

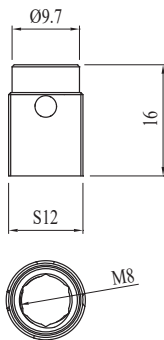

Kodas	Pastaba	g
084.312.004	M12/M8	20

Galvanised steel
Cinkuotas plienas
Acero galvanizado
Acier zingué
Verzinkter Stahl

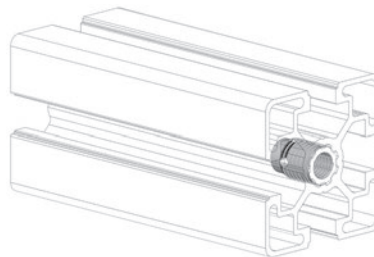



SRIEGINĖ ĮVORĖ

BOCCOLA FILETTATA
CASQUILLO ROSCADO
DOUILLE FILETÉE
GEWINDEBUCHSE



Kodas	Pastaba	d	A	D	B	s	g
084.312.007	-	M5	11,50	7	-	-	2
084.312.005 -		M6	14	9	-	-	2
084.312.006	-	M8	16,50	11	-	-	4

Galvanised steel
Cinkuotas plienas
Acero galvanizado
Acier zingué
Verzinkter Stahl

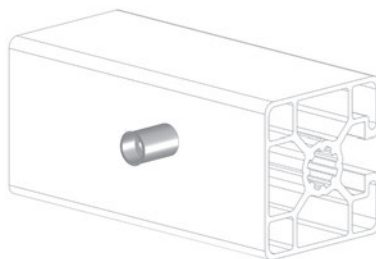
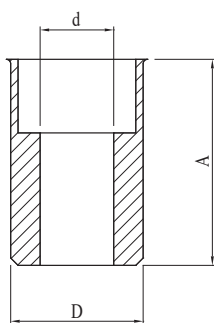



KVADRATINĖ POVERŽLĖ 16x16 Ø8,5



RONDELLA QUADRA
ARANDELA CUADRADA
RONDELLA QUADRA VIERKANTSCHIEBE

Kodas	Pastaba	g
084.303.007	16x16	1

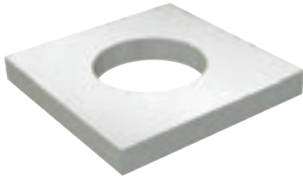

Galvanised steel
Cinkuotas plienas
Acero galvanizado
Acier zingué
Verzinkter Stahl

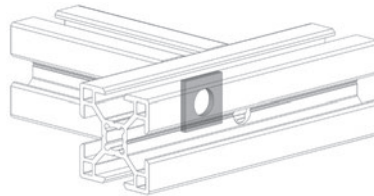
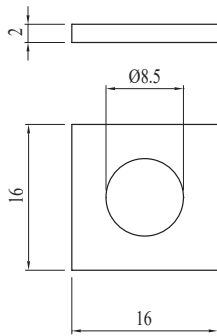

KVADRATINĖ POVERŽLĖ 19x19, Ø12,5



RONDELLA QUADRA
ARANDELA CUADRADA
RONDELLA QUADRA VIERKANTSCHIEBE

Kodas	Pastaba	g
084.303.004	19x19	1

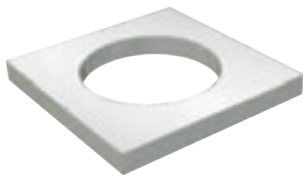

Galvanised steel
Cinkuotas plienas
Acero galvanizado
Acier zingué
Verzinkter Stahl

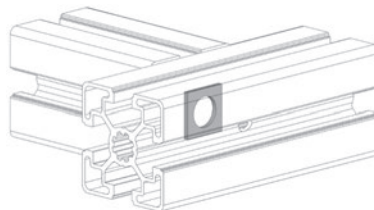
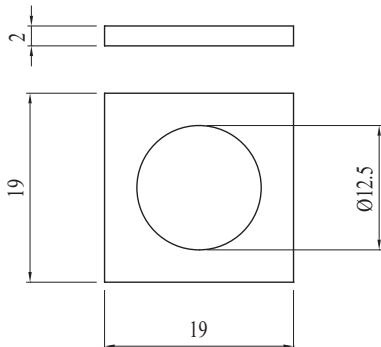



APSAUGOS NUO SUKIMO ĮTAISAS

DISPOSITIVO ANTIROTAZIONE
DISPOSITIVO ANTIRROTACIÓN
DISPOSITIF ANTI-ROTATION
VERDREHSICHERUNG



Kodas	Pastaba	g
084.303.008	For profile 084.112.002 - Profiliui 084.112.002 - Para perfil 084.112.002 - Pour profilé 084.112.002 - Für Profil 084.112.002	10

Black polyamide
Juodas poliamidas
Poliamida color negro
Polyamide noir
Polyamid schwarz

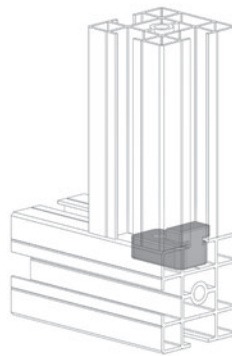
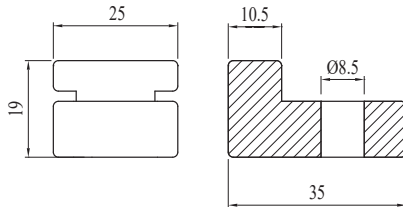

**KIAURYMĖS UŽDENGIMO DANGTELIS Ø7,5**

TAPPO CHIUDI FORO
TAPÓN TA PA-AGUJERO
BOUCHON DE FERMETURE TROU
ABDECKKAPPE FÜR LÖCHER

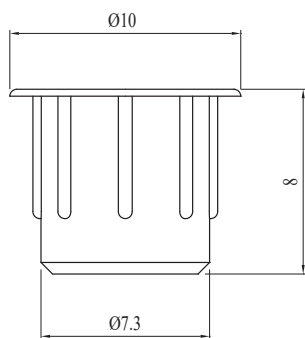

Kodas	Pastaba	Spalva	g
084.202.002	For Ø7.5 mm holes - Kiaurymėms Ø7,5 - Para orificios Ø7,5 - Pour trous Ø 7,5 - Für Löcher Ø7,5	B	1
084.202.002N	For Ø7.5 mm holes - Kiaurymėms Ø7,5 - Para orificios Ø7,5 - Pour trous Ø 7,5 - Für Löcher Ø7,5	A	1

Polyamide
Poliamidas
Poliamida
Polyamide
Polyamid

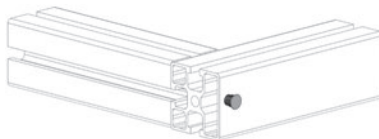
**KIAURYMĖS UŽDENGIMO DANGTELIS Ø13**

TAPPO CHIUDI FORO
TAPÓN TA PA-AGUJERO
BOUCHON DE FERMETURE TROU
ABDECKKAPPE FÜR LÖCHER

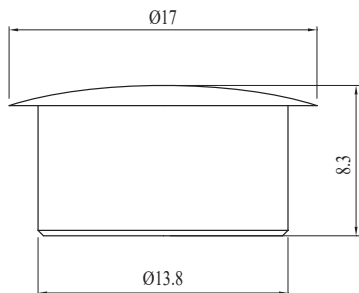

Kodas	Pastaba	Spalva	g
084.202.005	For Ø13 mm holes - Kiaurymėms Ø13 - Para orificios Ø13 - Pour trous Ø 13 - Für Löcher Ø13	B	1
084.202.005N	For Ø13 mm holes - Kiaurymėms Ø13 - Para orificios Ø13 - Pour trous Ø 13 - Für Löcher Ø13	A	1

Polyamide
Poliamidas
Poliamida
Polyamide
Polyamid

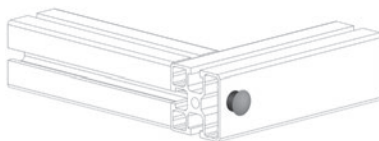



SRIEGIO UŽDENGIMO DANGTELIS M6

TAPPO CHIUSURA VITE
TAPÓN TA PA-TORNILLO
BOUCHON DE FERMETURE VIS
ABDECKKAPPE FÜR SCHRAUBEN

Kodas	Pastaba	g
084.202.006	M6 screw, 4 mm hex socket head - M6 varžtas, 4 mm šešiakampė galvutė - Tornillo M6 con hexágono de 4 mm - Vis M6 hexagone 4 - Schraube M6 Sechskant 4	1

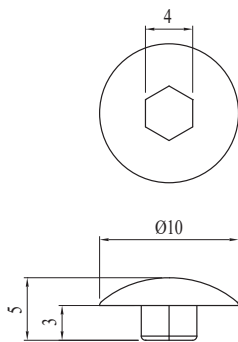

Pilkas poliamidas
Poliamidas pilkas
Poliamida color gris
Polyamide gris
Polyamid grau

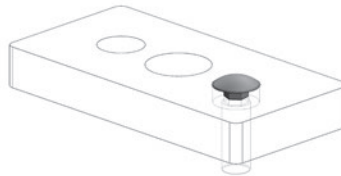

SRIEGIO UŽDENGIMO DANGTELIS M6

TAPPO CHIUSURA VITE
TAPÓN TA PA-TORNILLO
BOUCHON DE FERMETURE VIS
ABDECKKAPPE FÜR SCHRAUBEN

Kodas	Pastaba	g
084.202.009	M6 screw, 5 mm hex socket head - M6 varžtas, 5 mm šešiakampė galvutė - Tornillo M6 con hexágono de 5 mm - Vis M6 hexagone 5 - Schraube M6 Sechskant 5	1

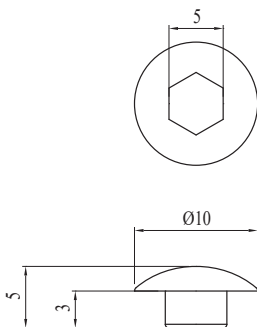

Pilkas poliamidas
Poliamidas pilkas
Poliamida color gris
Polyamide gris
Polyamid grau

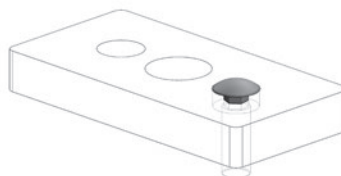



SRIEGIO UŽDENGIMO DANGTELIS M8

TAPPO CHIUSURA VITE
TAPÓN TA PA-TORNILLO
BOUCHON DE FERMETURE VIS
ABDECKKAPPE FÜR SCHRAUBEN

Kodas	Pastaba	g
084.202.007	M8 screw, 5 mm hex socket head - M6 varžtas, 5 mm šešiakampė galvutė -- Tornillo M8 con hexágono de 5 mm - Vis M8 hexagone 5 - Schraube M8 Sechskant 5	1



Pilkas poliamidas
Poliamidas pilkas
Poliamida color gris
Polyamide gris
Polyamid grau

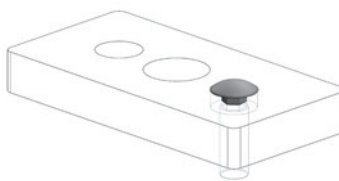
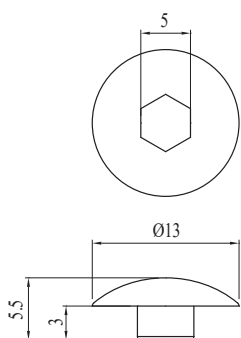

SRIEGIO UŽDENGIMO DANGTELIS M8

TAPPO CHIUSURA VITE
TAPÓN TA PA-TORNILLO
BOUCHON DE FERMETURE VIS
ABDECKKAPPE FÜR SCHRAUBEN

Kodas	Pastaba	g
084.202.008	M8 screw, 6 mm hex socket head - M6 varžtas, 6 mm šešiakampė galvutė - Tornillo M8 con hexágono de 6 mm - Vis M8 hexagone 6 - Schraube M8 Sechskant 6	1



Pilkas poliamidas
Poliamidas pilkas
Poliamida color gris
Polyamide gris
Polyamid grau

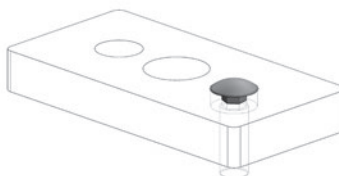
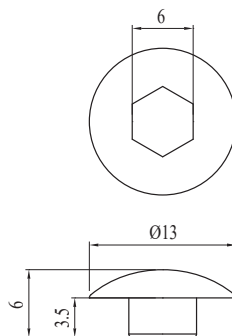



GREITO SUJUNGIMO JUNGTIS



NOTTOLINO RACORD
CENTRAL FIXATION
UNIVERSELLE EN T
ZENTRALVERBINDER

Kodas	Pastaba	g
084.306.014	Vertical - Vertikalus - Vertical - Vertical - Vertikal	19



Galvanised steel
Cinkuotas plienas
Acero galvanizado
Acier zingué
Verzinkter Stahl

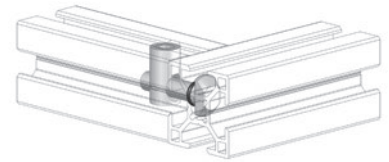
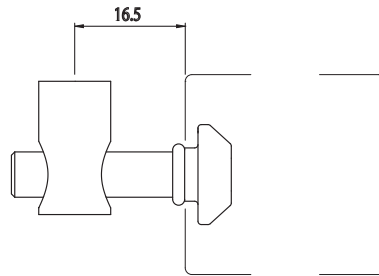
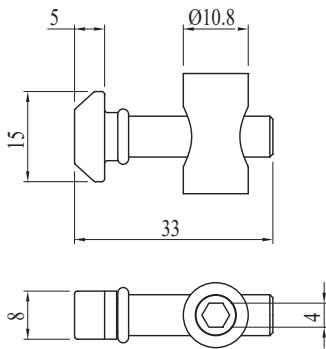

GREITO SUJUNGIMO JUNGTIS



NOTTOLINO RACORD
CENTRAL FIXATION
UNIVERSELLE EN T
ZENTRALVERBINDER

Kodas	Pastaba	g
084.306.015	Horizontal - Horizontalus - Horizontal - Horizontal - Horizontal	19



Galvanised steel
Cinkuotas plienas
Acero galvanizado
Acier zingué
Verzinkter Stahl

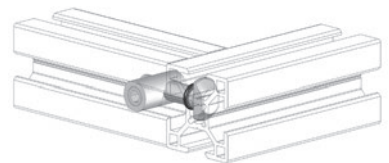
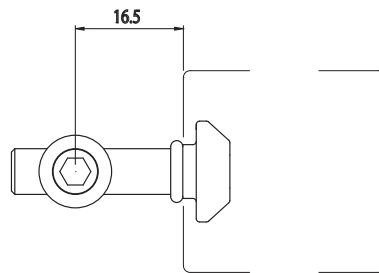
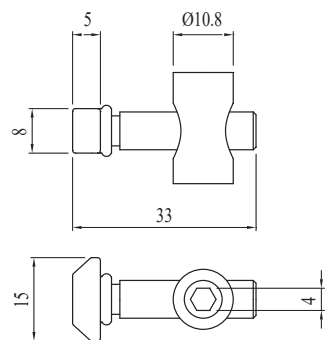



GREITO SUJUNGIMO JUNGTTIS

NOTTOLINO RACORD
CENTRAL FIXATION
UNIVERSELLE EN T
ZENTRALVERBINDER

BH 10 40 BH L 10 45 BH H 10 45 BH 10 50

Kodas	Pastaba	g
084.306.008	Vertical - Vertikali - Vertical - Vertical - Vertikal	49



Galvanised steel
Cinkuotas plienas
Acero galvanizado
Acier zingué
Verzinkter Stahl

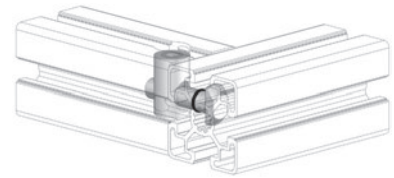
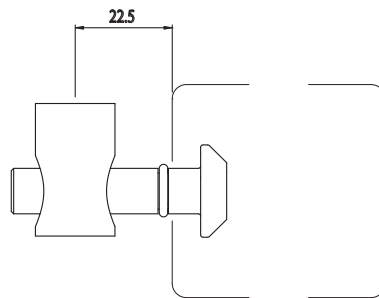
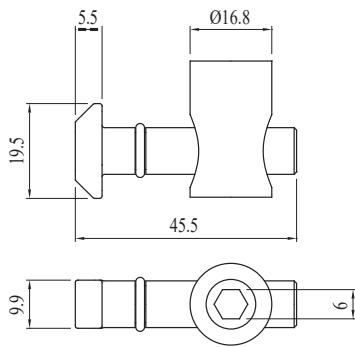

GREITO SUJUNGIMO JUNGTTIS

NOTTOLINO RACORD
CENTRAL FIXATION
UNIVERSELLE EN T
ZENTRALVERBINDER

BH 10 40 BH L 10 45 BH H 10 45 BH 10 50

Kodas	Pastaba	g
084.306.009	Horizontal - Horizontali - Horizontal - Horizontal - Horizontal	49



Galvanised steel
Cinkuotas plienas
Acero galvanizado
Acier zingué
Verzinkter Stahl

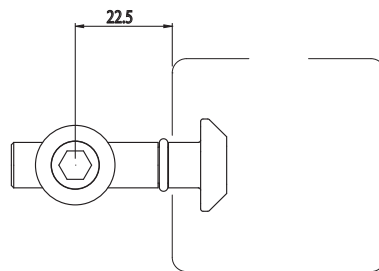
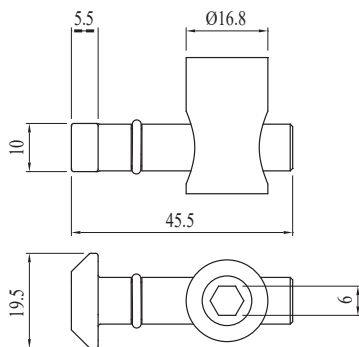



GREITO SUJUNGIMO JUNGTIS

NOTTOLINO RACORD
CENTRAL FIXATION
UNIVERSELLE EN T
ZENTRALVERBINDER

BH 10 L 40 BH L 10 L 45 BH H 10 H 45 BH H 10 H 50

Kodas	Pastaba	g
084.306.017	Horizontally articulated - Horizontaliai orientuota - Articuable horizontal - Articulable horizontal - Verstellbar, horizontal	89



Galvanised steel
Cinkuotas plienas
Acero galvanizado
Acier zingué
Verzinkter Stahl

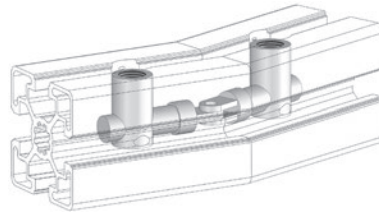
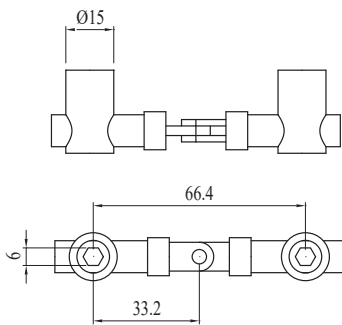

GREITO SUJUNGIMO JUNGTIS

NOTTOLINO RACORD
CENTRAL FIXATION
UNIVERSELLE EN T
ZENTRALVERBINDER

BH 10 L 40 BH L 10 L 45 BH H 10 H 45 BH H 10 H 50

Kodas	Pastaba	g
084.306.018	Vertically articulated - Vertikaliai orientuota - Articuable vertical - Articulable vertical - Verstellbar, vertikal	89



Galvanised steel
Cinkuotas plienas
Acero galvanizado
Acier zingué
Verzinkter Stahl

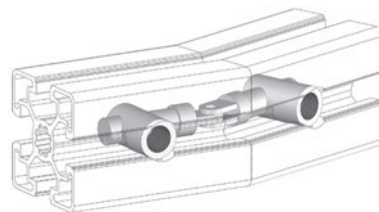
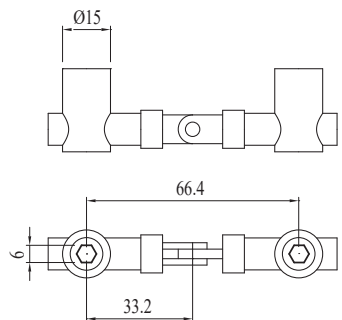



FREZAVIMO JUNGTIS

RACCORDO 90°
RACOR 90°
RACCORD 90°
FRÄSVERBINDER

BH 10 40 BH L 10 45 BH H 10 45 BH 10 50

Kodas	Pastaba	g
084.306.013	Connector in slot - Jungtis lizde - Racor en ranura - Raccord dans rainure - Verbindungsstück in Nut	39



Galvanised steel
Cinkuotas plienas
Acero galvanizado
Acier zingué
Verzinkter Stahl

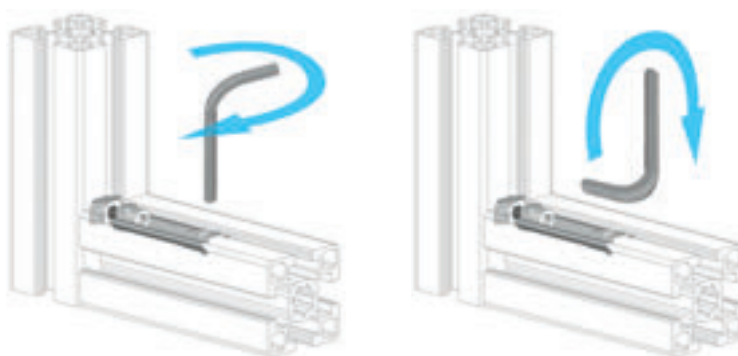
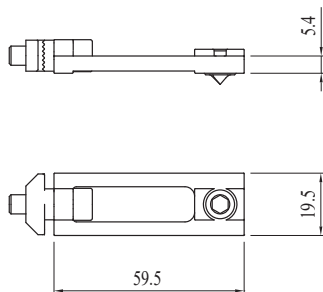

30° KAMPINĖ JUNGTIS

GIUNTO ANGOLARE 30°
ESCUADRA 30°
EQUERRE INTERNE 30°
GEHRUNGSVERBINDER 30°

BH 6 20

Kodas	Pastaba	g
084.307.039	Complete with 4 x M5x5 grub screws - Komplekte su 4 x M5x5 varžtais - Incluye 4 tornillos sin cabeza M5x5 - Avec 4 pions M5x5 - Einschließlich 4 Stifte M5x5	11



Galvanised steel
Cinkuotas plienas
Acero galvanizado
Acier zingué
Verzinkter Stahl

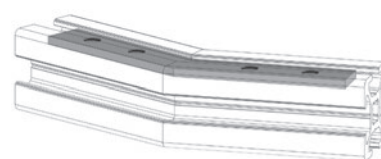
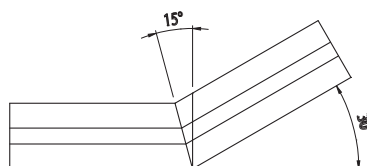
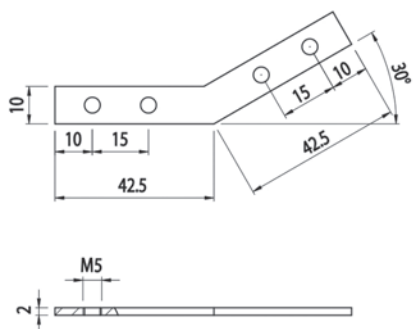



45° KAMPINĖ JUNGTIS



GIUNTO ANGOLARE 45°
 ESCUADRA 45°
 EQUERRE INTERNE 45°
 GEHRUNGSVERBINDER 45°

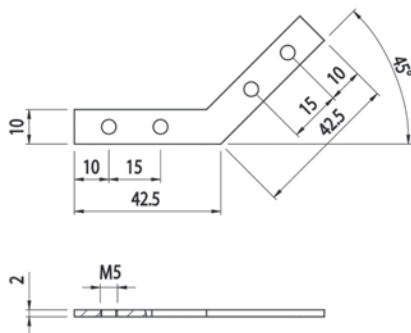

Kodas	Pastaba	g
084.307.040	Complete with 4 x M5x5 grub screws - Komplekte su 4 varžtais M5x5 - Incluye 4 tornillos sin cabeza M5x5 - Avec 4 pions M5x5 - Einschließlich 4 Stifte M5x5	11

Galvanised steel
 Cinkuotas plienas
 Acero galvanizado
 Acier zingué
 Verzinkter Stahl

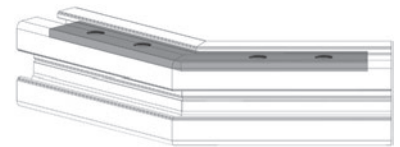
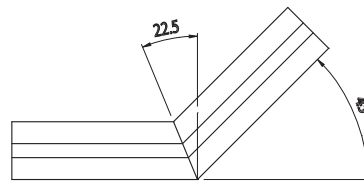

60° KAMPINĖ JUNGTIS



GIUNTO ANGOLARE 60°
 ESCUADRA 60°
 EQUERRE INTERNE 60°
 GEHRUNGSVERBINDER 60°

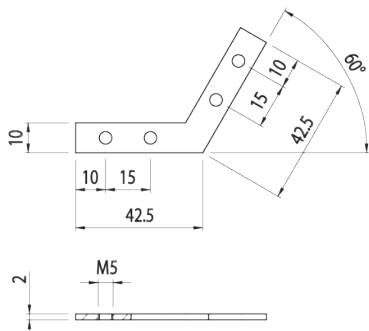

Kodas	Pastaba	g
084.307.041	Complete with 4 x M5x5 grub screws - Komplekte su 4 varžtais M5x5 - Incluye 4 tornillos sin cabeza M5x5 - Avec 4 pions M5x5 - Einschließlich 4 Stifte M5x5	11

Galvanised steel
 Cinkuotas plienas
 Acero galvanizado
 Acier zingué
 Verzinkter Stahl

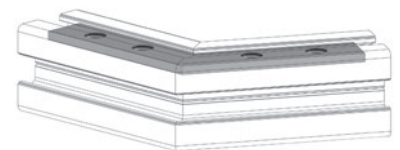
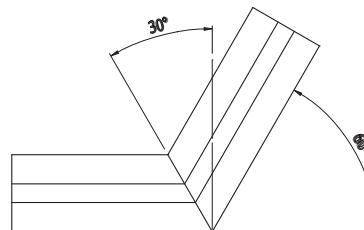



90° KAMPINĖ JUNGTIS



GIUNTO ANGOLARE 90°
ESCUADRA 90°
EQUERRE INTERNE 90°
GEHRUNGSVERBINDER 90°



Kodas	Pastaba	g
084.307.042	Complete with 4 x M5x5 grub screws - Komplekte su 4 varžtais M5x5 - Incluye 4 tornillos sin cabeza M5x5 - Avec 4 pions M5x5 - Einschließlich 4 Stifte M5x5	11

Galvanised steel
Cinkuotas plienas
Acero galvanizado
Acier zingué
Verzinkter Stahl

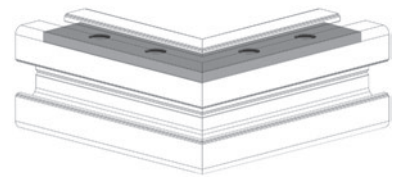
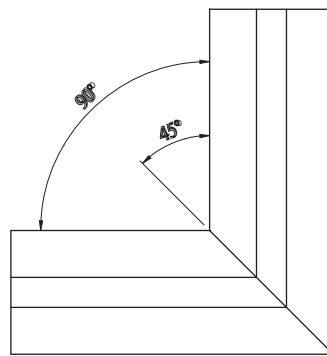
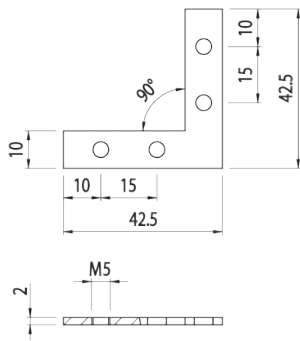

30° KAMPINĖ JUNGTIS



GIUNTO ANGOLARE 30°
ESCUADRA 30°
EQUERRE INTERNE 30°
GEHRUNGSVERBINDER 30°



Kodas	Pastaba	g
084.307.043	Complete with 4 x M6x8 grub screws - Komplekte su 4 varžtais M6x8 - Incluye 4 tornillos sin cabeza M6x8 - Avec 4 pions M6x8 - Einschließlich 4 Stifte M6x8	38

Galvanised steel
Cinkuotas plienas
Acero galvanizado
Acier zingué
Verzinkter Stahl

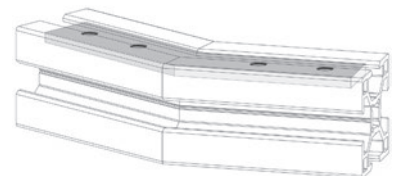
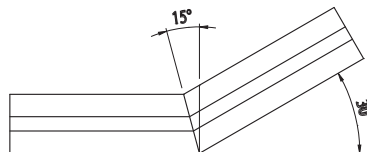
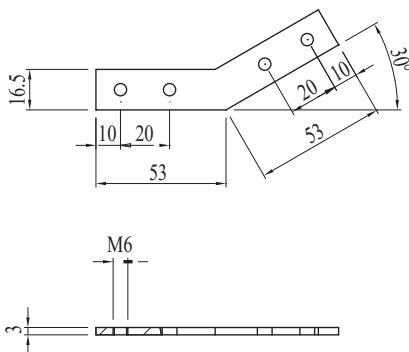

**45° KAMPINĖ JUNGTIS**

GIUNTO ANGOLARE 45°
 ESCUADRA 45°
 EQUERRE INTERNE 45°
 GEHRUNGSVERBINDER 45°

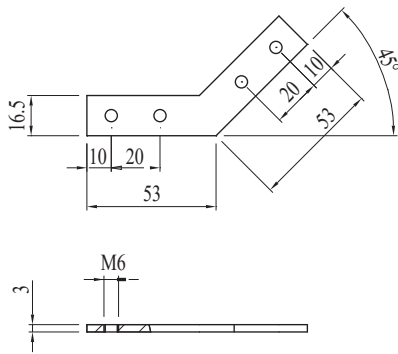

Kodas	Pastaba	g
084.307.044	Complete with 4 x M6x8 grub screws - Komplekte su 4 varžtais M6x8 - Incluye 4 tornillos sin cabeza M6x8 - Avec 4 pions M6x8 - Einschließlich 4 Stifte M6x8	38

Galvanised steel
 Cinkuotas plienas
 Acero galvanizado
 Acier zingué
 Verzinkter Stahl

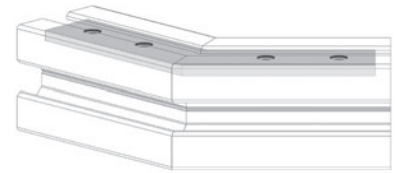
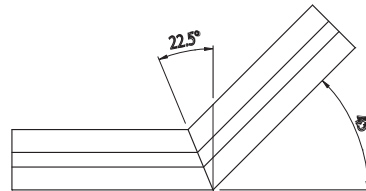
**60° KAMPINĖ JUNGTIS**

GIUNTO ANGOLARE 60°
 ESCUADRA 60°
 EQUERRE INTERNE 60°
 GEHRUNGSVERBINDER 60°

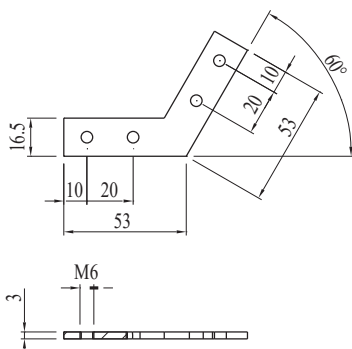

Kodas	Pastaba	g
084.307.045	Complete with 4 x M6x8 grub screws - Komplekte su 4 varžtais M6x8 - Incluye 4 tornillos sin cabeza M6x8 - Avec 4 pions M6x8 - Einschließlich 4 Stifte M6x8	38

Galvanised steel
 Cinkuotas plienas
 Acero galvanizado
 Acier zingué
 Verzinkter Stahl

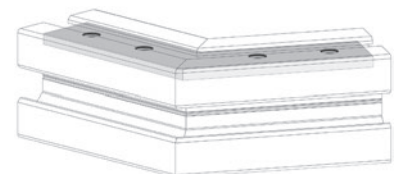
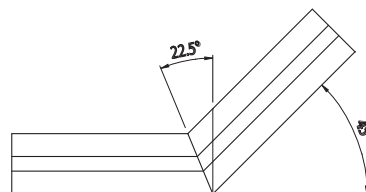



90° KAMPINĖ JUNGTIS



GIUNTO ANGOLARE 90°
ESCUADRA 90°
EQUERRE INTERNE 90°
GEHRUNGSVERBINDER 90°



Kodas	Pastaba	g
084.307.046	Complete with 4 x M6x8 grub screws - Komplekte su 4 varžtais M6x8 - Incluye 4 tornillos sin cabeza M6x8 - Avec 4 pions M6x8 - Einschließlich 4 Stifte M6x8	38

Galvanised steel
Cinkuotas plienas
Acero galvanizado
Acier zingué
Verzinkter Stahl

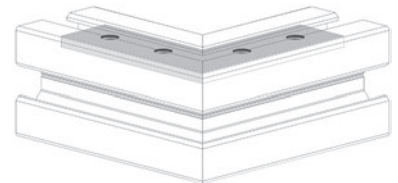
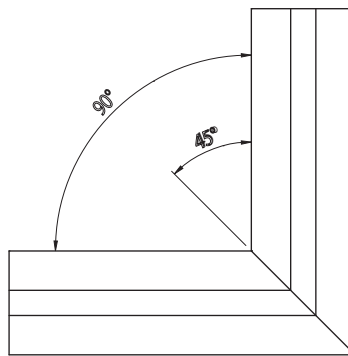
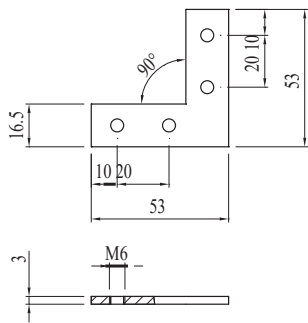

30° KAMPINĖ JUNGTIS



GIUNTO ANGOLARE 30°
ESCUADRA 30°
EQUERRE INTERNE 30°
GEHRUNGSVERBINDER 30°



Kodas	Pastaba	g
084.307.047	Complete with 4 x M8x12 grub screws - Komplekte su 4 varžtais M8x12 - Incluye 4 tornillos sin cabeza M8x12 - Avec 4 pions M8x12 - Einschließlich 4 Stifte M8x12	36

Galvanised steel
Cinkuotas plienas
Acero galvanizado
Acier zingué
Verzinkter Stahl

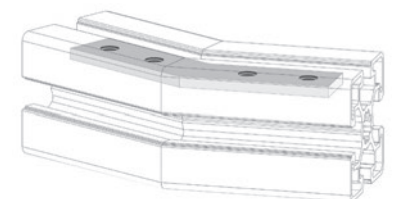
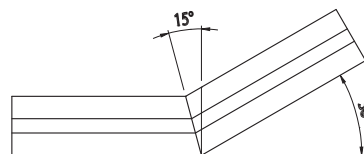
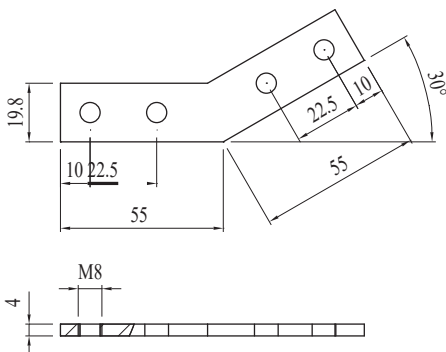



45° KAMPINĖ JUNGTIS

GIUNTO ANGOLARE 45°
ESCUADRA 45°
EQUERRE INTERNE 45°
GEHRUNGSVERBINDER 45°

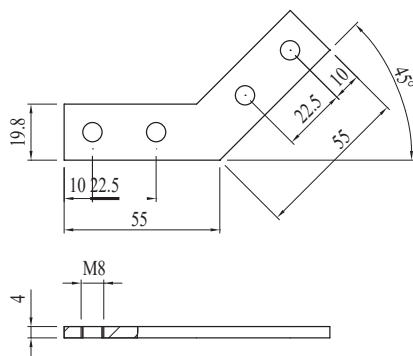

Kodas	Pastaba	g
084.307.048	Complete with 4 x M8x12 grub screws - Komplekte su 4 varžtais M8x12 - Incluye 4 tornillos sin cabeza M8x12 - Avec 4 pions M8x12 - Einschließlich 4 Stifte M8x12	36

Galvanised steel
Cinkuotas plienas
Acero galvanizado
Acier zingué
Verzinkter Stahl

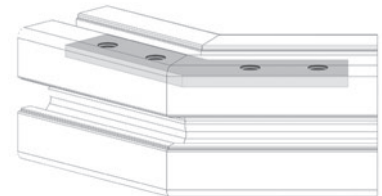
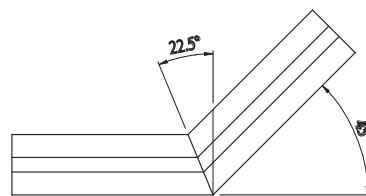

60° KAMPINĖ JUNGTIS

GIUNTO ANGOLARE 60°
ESCUADRA 60°
EQUERRE INTERNE 60°
GEHRUNGSVERBINDER 60°

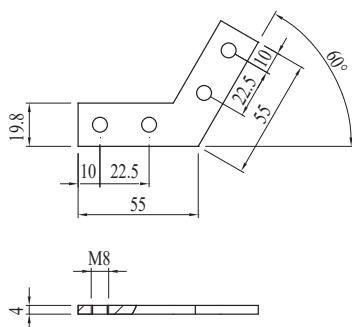

Kodas	Pastaba	g
084.307.049	Complete with 4 x M8x12 grub screws - Komplekte su 4 varžtais M8x12 - Incluye 4 tornillos sin cabeza M8x12 - Avec 4 pions M8x12 - Einschließlich 4 Stifte M8x12	36

Galvanised steel
Cinkuotas plienas
Acero galvanizado
Acier zingué
Verzinkter Stahl

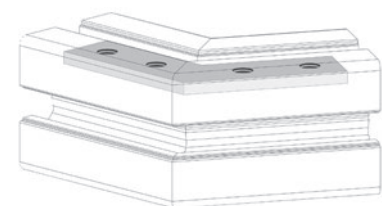
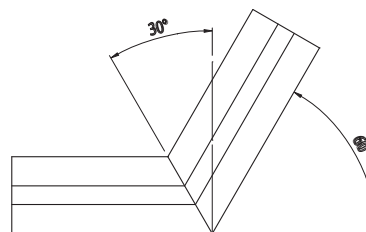



90° KAMPINĖ JUNGTIS



GIUNTO ANGOLARE 90°
ESCUADRA 90°
EQUERRE INTERNE 90°
GEHRUNGSVERBINDER 90°

Kodas	Pastaba	g
084.307.050	Complete with 4 x M8x12 grub screws - Komplekte su 4 varžtais M8x12 - Incluye 4 tornillos sin cabeza M8x12 - Avec 4 pions M8x12 - Einschließlich 4 Stifte M8x12	36



Galvanised steel
Cinkuotas plienas
Acero galvanizado
Acier zingué
Verzinkter Stahl

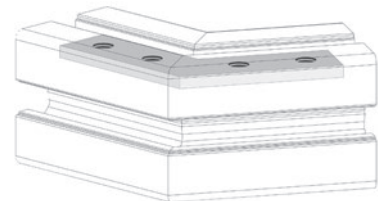
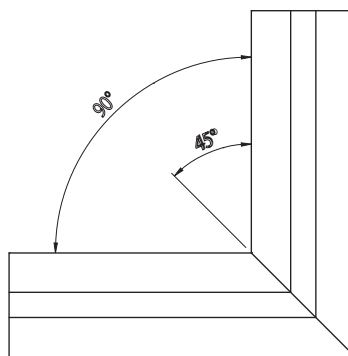
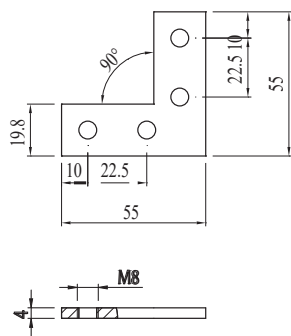

**100 mm PROFILIO JUNGTTIS**

GIUNTO LINEARE 100 mm EM
PALME LINEAL 100 mm
JOINT LINÉAIRE 100 mm
STRECKENVERBINDER 100 mm

Kodas	Pastaba	g
084.307.037	Complete with 4 x M5 grub screws - Komplekte su 4 varžtais M5 - Incluye 4 tornillos sin cabeza M5 - Avec 4 pions M5 - Einschließlich 4 Stifte M5	27

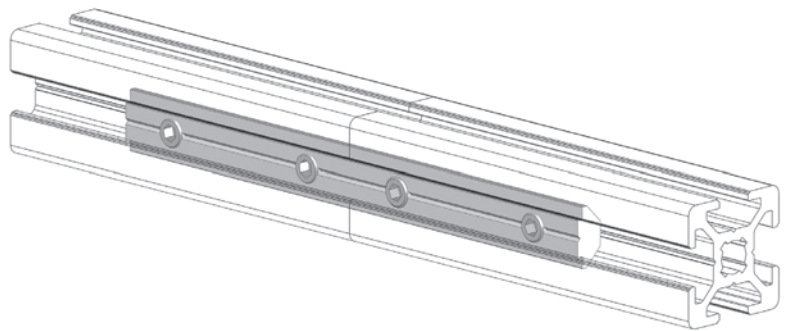
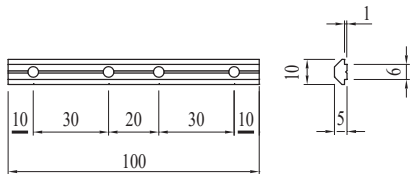

Galvanised steel
Cinkuotas plienas
Acero galvanizado
Acier zingué
Verzinkter Stahl

**180 mm PROFILIO JUNGTTIS**

GIUNTO LINEARE 180 mm EM
PALME LINEAL 180 mm
JOINT LINÉAIRE 180 mm
STRECKENVERBINDER 180 mm

Kodas	Pastaba	g
084.307.051	Complete with 4 x M5 grub screws - Komplekte su 4 varžtais M5 - Incluye 4 tornillos sin cabeza M5 - Avec 4 pions M5 - Einschließlich 4 Stifte M5	27



Galvanised steel
Cinkuotas plienas
Acero galvanizado
Acier zingué
Verzinkter Stahl

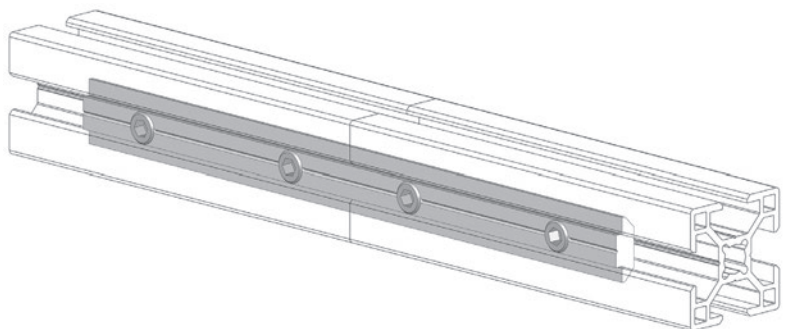
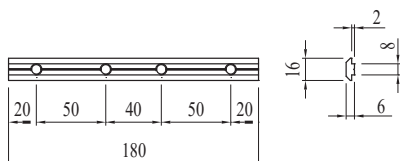



90 mm PROFILIO JUNGTIS



GIUNTO LINEARE 90 mm EM
PALME LINEAL 90 mm
JOINT LINÉAIRE 90 mm
STRECKENVERBINDER 90 mm

Kodas	Pastaba	g
084.307.024	Complete with 2 x M8 grub screws - Komplekte su 2 varžtais M8 - Incluye 2 tornillos sin cabeza M8 - Avec 2 pions M8 - Einschließlich 2 Stifte M8	80



Galvanised steel
Cinkuotas plienas
Acero galvanizado
Acier zingué
Verzinkter Stahl

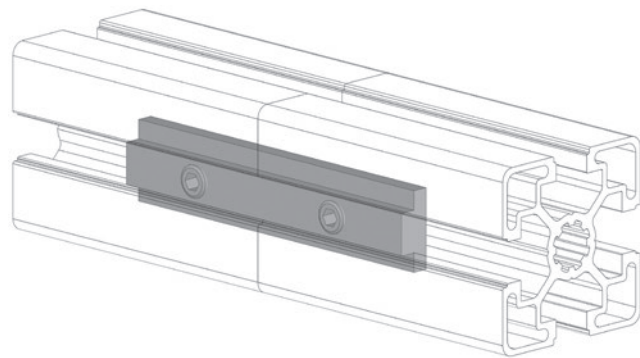
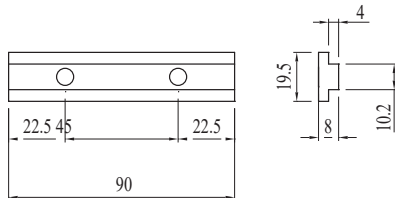

180 mm PROFILIO JUNGTIS



GIUNTO LINEARE 180 mm EM
PALME LINEAL 180 mm
JOINT LINÉAIRE 180 mm
STRECKENVERBINDER 180 mm

Kodas	Pastaba	g
084.307.025	Complete with 4 x M8 grub screws - Komplekte su 4 varžtais M8 - Incluye 4 tornillos sin cabeza M8 - Avec 4 pions M8 - Einschließlich 4 Stifte M8	160



Galvanised steel
Cinkuotas plienas
Acero galvanizado
Acier zingué
Verzinkter Stahl

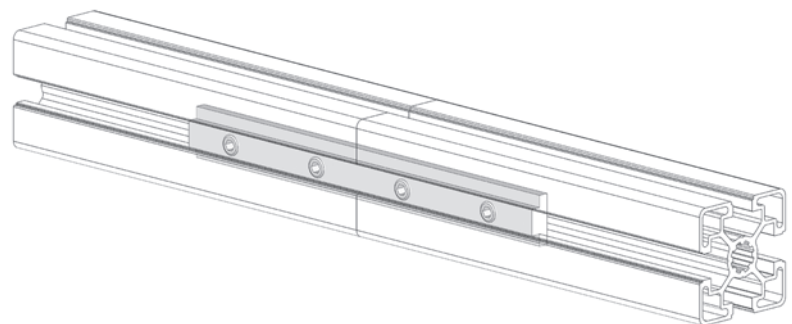
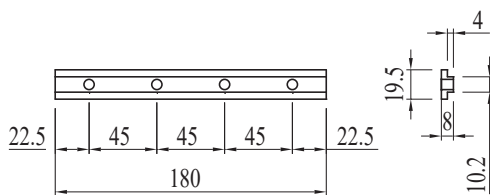

**JUNGTIES PLOKŠTĖ 40x80**

PIASTRA DI GIUNZIONE PLACA DE
ACOPLAMIENTO PLATINE
D'ASSEMBLAGE VERBINDERPLATTE

Kodas	Pastaba	g
084.710.002	For 40x40 and 45x45 profiles - Profiliams 40x40 ir 45x45 - Para perfiles 40x40 y 45x45 - Pour profilés 40x40 et 45x45 - Für Profile 40x40 und 45x45	88

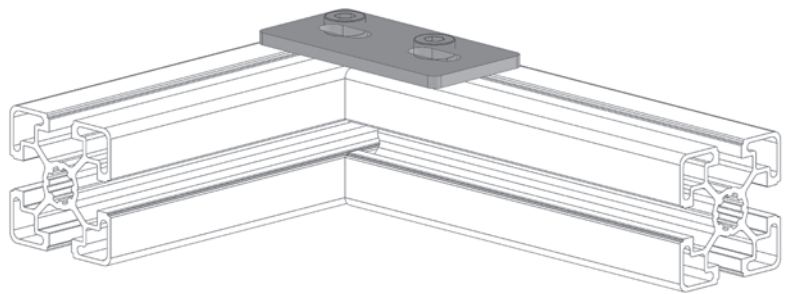
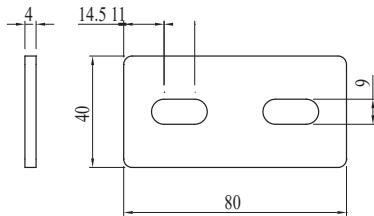

Galvanised steel
Cinkuotas plienas
Acero galvanizado
Acier zingué
Verzinkter Stahl

**JUNGTIES PLOKŠTĖ 40x120**

PIASTRA DI GIUNZIONE PLACA DE ACOPLAMIENTO
PLATINE D'ASSEMBLAGE VERBINDERPLATTE

Kodas	Pastaba	g
084.710.004	For 40x40 and 45x45 profiles - Profiliams 40x40 ir 45x45 - Para perfiles 40x40 y 45x45 - Pour profilés 40x40 et 45x45 - Für Profile 40x40 und 45x45	132



Galvanised steel
Cinkuotas plienas
Acero galvanizado
Acier zingué
Verzinkter Stahl

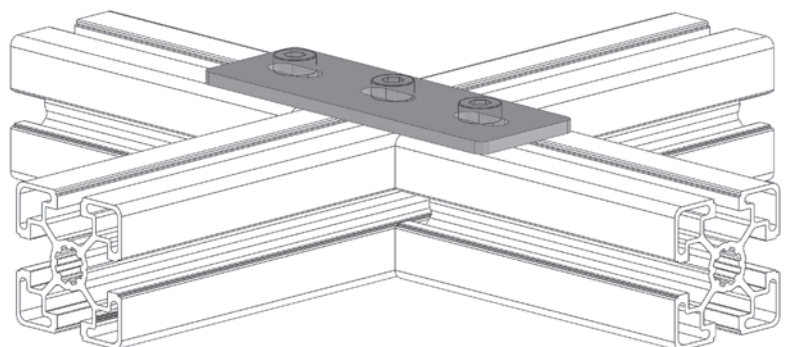
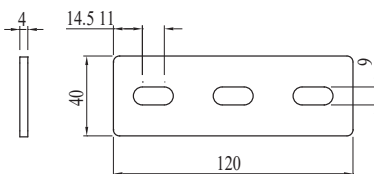



JUNGTIJS PLOKŠTĖ 80x160



PIASTRA DI GIUNZIONE PLACA DE ACOPLAMIENTO PLATINE D'ASSEMBLAGE VERBINDERPLATTE

Kodas	Pastaba	g
084.710.003	For 40x80 and 80x80 profiles - Profiliams 40x80 ir 80x80 - Para perfiles 40x80 y 80x80 - Pour profilés 40x80 et 80x80 - Für Profile 40x80 und 80x80	730



Galvanised steel
Cinkuotas plienas
Acero galvanizado
Acier zingué
Verzinkter Stahl

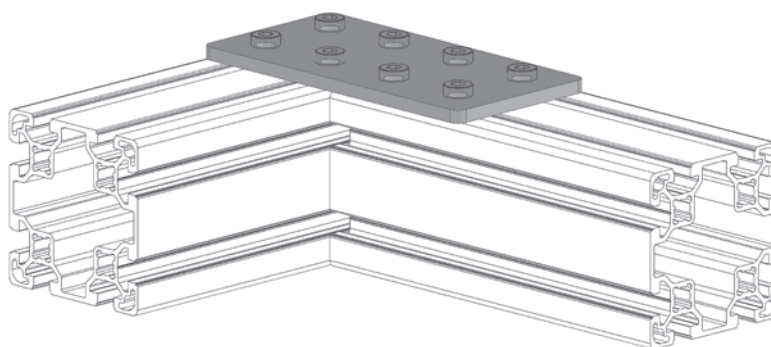
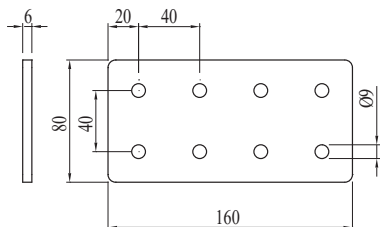

JUNGTIJS PLOKŠTĖ 90x180



PIASTRA DI GIUNZIONE PLACA DE ACOPLAMIENTO PLATINE D'ASSEMBLAGE VERBINDERPLATTE

Kodas	Pastaba	g
084.710.001	For 45x90 and 90x90 profiles - Profiliams 45x90 ir 90x90 - Para perfiles 45x90 y 90x90 - Pour profilés 45x90 et 90x90 - Für Profile 45x90 und 90x90	730



Galvanised steel
Cinkuotas plienas
Acero galvanizado
Acier zingué
Verzinkter Stahl

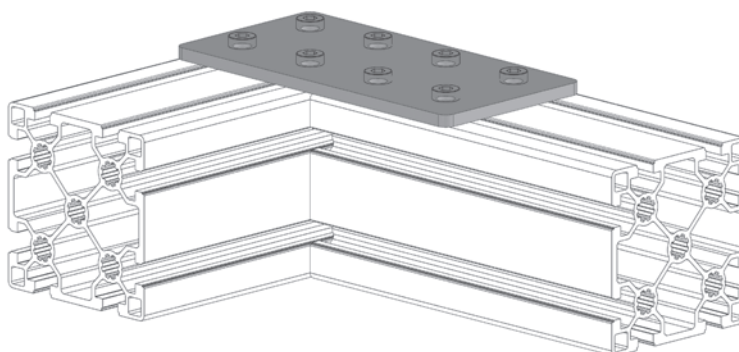
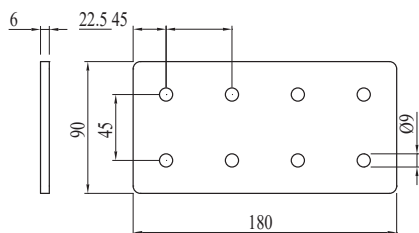



JUNGTIŲ PLOKŠTĖ

PIASTRA DI GIUNZIONE
PLACA DE
ACOPAMIENTO PLATINE
D'ASSEMBLAGE
VERBINDERPLATTE

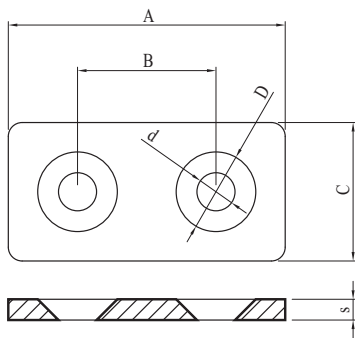

NEW

Kodas	Pastaba	A	B	C	D	d	s	g
084.710.006N	20x20	40	20	20	11,5	5,5	3	16
084.710.007N	30x30	60	30	30	13	7	3	38
084.710.008N	40x40	80	40	40	18	9,2	4	90
084.710.009N	45x45	90	45	45	19,2	9,2	5	145

Black painted steel
juodas dažytas plienas
verniciato nero
Acero barnizado en negro
Acier peint noir
Stahl schwarz lackiert

Grey painted steel on request
Pilka dažytas plienas pagal užsakymą
Acero barnizado en gris bajo solicitud
Acier peint gris sur demande
Stahl grau lackiert auf Anfrage

Galvanised steel on request
Cinkuotas plienas pagal užsakymą
galvanizado bajo solicitud
Acier zingué sur demande
Verzinkter Stahl auf Anfrage

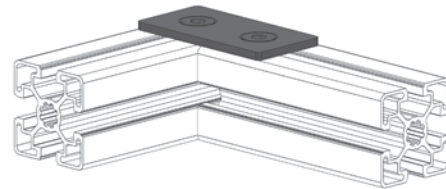



VIDINIS LAIKIKLIS 13,5x20



GIUNTO INTERNO ESCUADRA
INTERNA EQUERRE INTERNE
INNENVERBINDER



Kodas	Pastaba	g
084.307.036	Complete with 2 x M5 grub screws - Komplekte su 2 varžtais M5 - Incluye 2 tornillos sin cabeza M5 - Avec 2 pions M5 - Einschließlich 2 Stifte M5	6,50

Galvanised steel
Cinkuotas plienas
Acero galvanizado
Acier zingué
Verzinkter Stahl

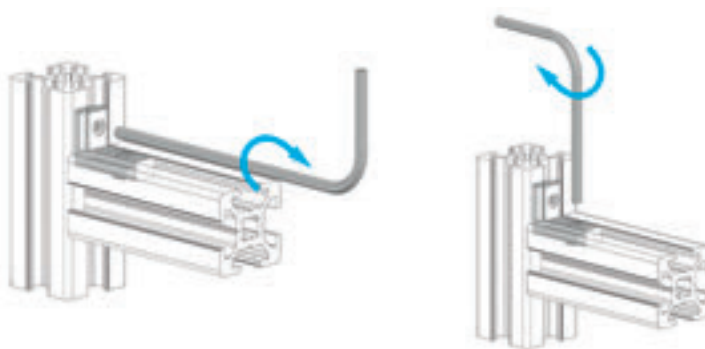
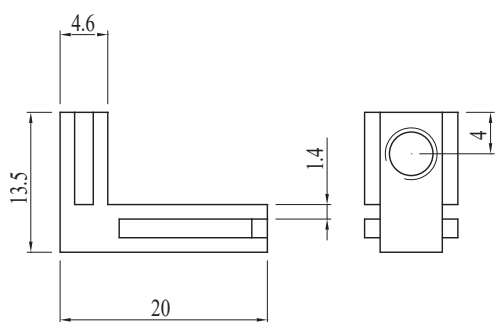

VIDINIS LAIKIKLIS 21x30



GIUNTO INTERNO ESCUADRA
INTERNA EQUERRE INTERNE
INNENVERBINDER



Kodas	Pastaba	g
084.307.052	Complete with 2 grub screws - Komplekte su 2 varžtais - Incluye 2 tornillos sin cabeza - Avec 2 pions - Einschließlich 2 Stifte	22

Galvanised steel
Cinkuotas plienas
Acero galvanizado
Acier zingué
Verzinkter Stahl

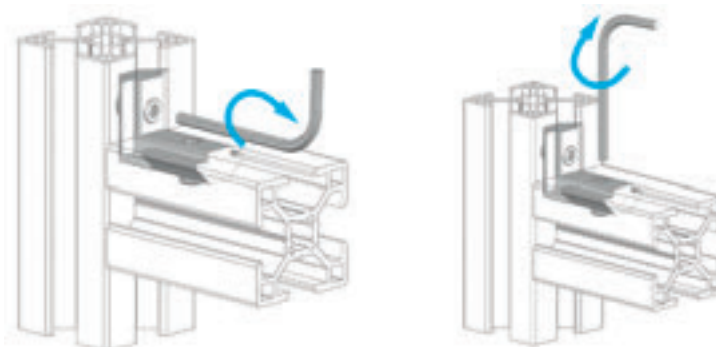
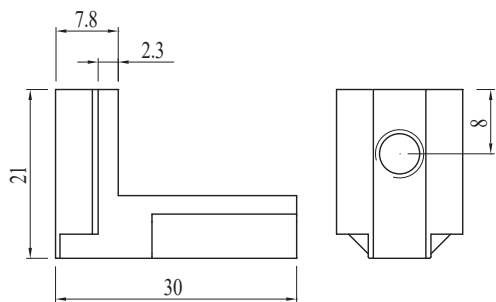



VIDINIS LAIKIKLIS 32x32



GIUNTO INTERNO ESCUADRA INTERNA
EQUERRE INTERNE INNENVERBINDER

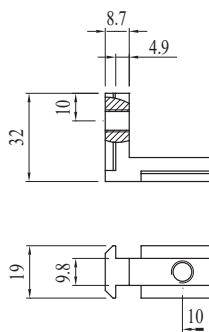

Kodas	Pastaba	g
084.307.053	Complete with 2 grub screws - Komplekte su 2 varžtais - Incluye 2 tornillos sin cabeza - Avec 2 pions - Einschließlich 2 Stifte	40

Galvanised steel
Cinkuotas plienas
Acero galvanizado
Acier zingué
Verzinkter Stahl

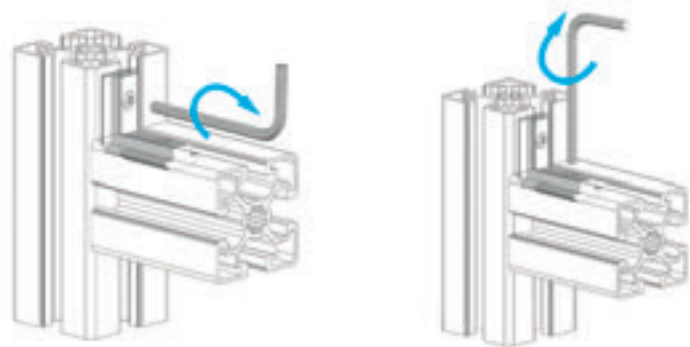

VIDINIS LAIKIKLIS 42x 27



GIUNTO INTERNO ESCUADRA INTERNA
EQUERRE INTERNE INNENVERBINDER

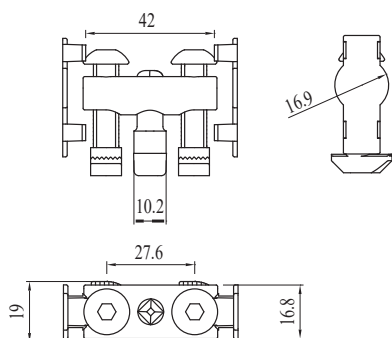

Kodas	Pastaba	g
084.307.031	Jungtis su kištuku - Connettore con perno passante - Conector con perno pasante - Connecteur avec pivot passant - Steckverbinder mit Durchsteckbolzen	75

Galvanised steel
Cinkuotas plienas
Acero galvanizado
Acier zingué
Verzinkter Stahl

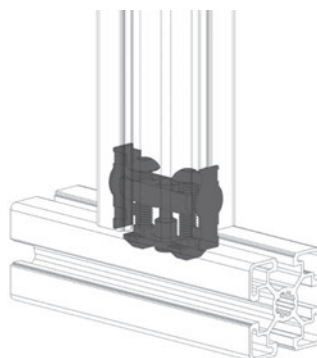



VIDINIS LAIKIKLIS 73x87

BH L 10 45 BH H 10 45

GIUNTO INTERNO ESCUADRA
INTERNA EQUERRE INTERNE
INNENVERBINDER



Kodas	Pastaba	g
084.307.032	Connector with through-pin - Jungtis su kištuku - Conector con perno pasante - Connecteur avec pivot passant - Steckverbinder mit Durchsteckbolzen	130

Galvanised steel
Cinkuotas plienas
Acero galvanizado
Acier zingué
Verzinkter Stahl

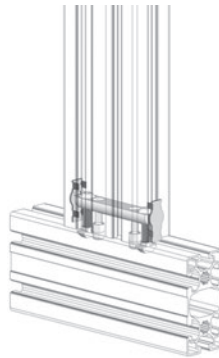
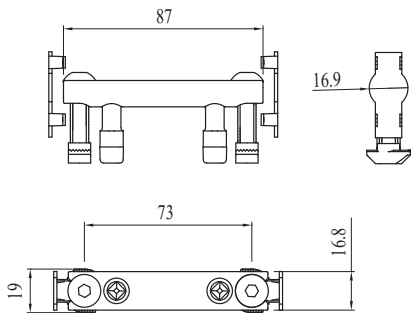

AUTOMATINĖ JUNGDIS 20xD12

BH 10 40 BH H 10 45

GIUNTO INTERNO
UNIÓN INTERNA
LIAISON SANS USINAGE
AUTOMATIKVERBINDER



Kodas	Pastaba	g
084.312.014	Screw and nut included -Varžtas ir veržlė pridedami - Tornillo y tuerca incluidos - Vis et écrou fournis - Schraube und Mutter im Lieferumfang enthalten	13

Galvanised steel
Cinkuotas plienas
Acero galvanizado
Acier zingué
Verzinkter Stahl

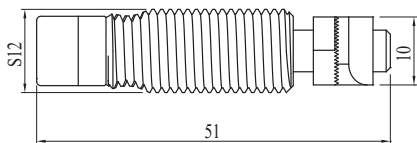

**KUBINĖ JUNGTIS 2D 45x45**

GIUNTO 2 VIE
CONECTOR CÚBICO 2D RACCORD CUBE 2D
WÜRFELERBINDER 2D



Kodas	Pastaba	g
084.310.020	Complete with plastic caps - Su plastikiniais dangteliais - Incluye tapones de plástico - Avec bouchons en plastique - Einschließlich Abdeckkappen aus Kunststoff	170

Galvanised steel
Cinkuotas plienas
Acero galvanizado
Acier zingué
Verzinkter Stahl

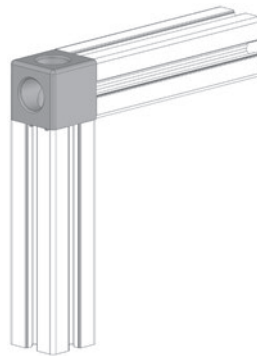
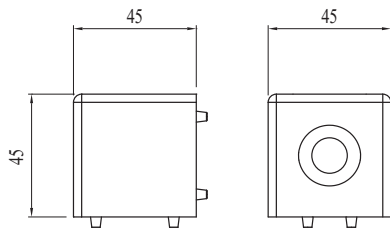
**KUBINĖ JUNGTIS 3D 45x45**

GIUNTO 3 VIE CONECTOR CÚBICO 3D
RACCORD CUBE 3D WÜRFELVERBINDER 3D



Kodas	Pastaba	g
084.310.021	Komplekte su tappi in plastica - Su plastikiniais dangteliais - Incluye tapones de plástico - Avec bouchons en plastique - Einschließlich Abdeckkappen aus Kunststoff	152

Galvanised steel
Cinkuotas plienas
Acero galvanizado
Acier zingué
Verzinkter Stahl

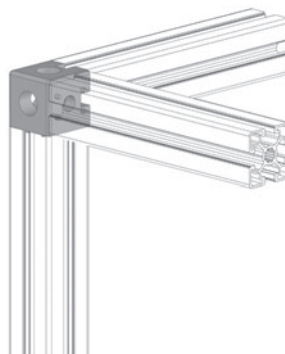
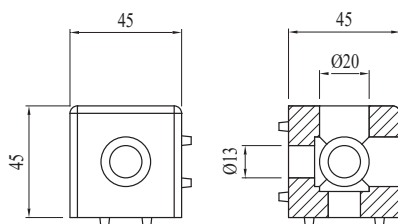



TRIJŲ KRYPČIŲ KAMPAS



GIUNTO 3 VIE
 ESCUADRA 3 VÍAS
 EQUERRE 3 VOIES
 3-WEGE ECKWINKEL

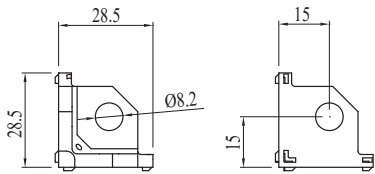

Kodas	Pastaba	g
084.310.022	Screws included - Komplekte su varžtais - Tornillos incluidos - Vis fournies - Schrauben im Lieferumfang enthalten	15

Sandblasted aluminium
 Smėliapūte apdorotas aliuminis
 Aluminio arenado
 Aluminium sablé
 Sandgestrahltes Aluminium

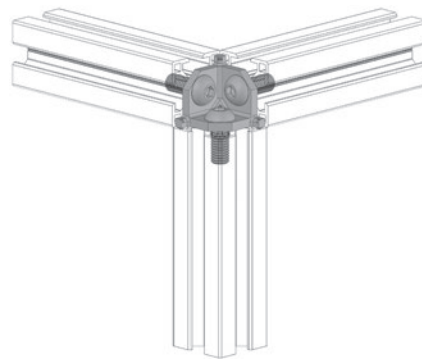

SFERINIS DANGTELIS 30x30



TAPPO TONDO 3 VIETA PA PARA ESCUADRA
 EMBOUT EQUERRE
 ABDECKKAPPE FÜR ECKWINKEL

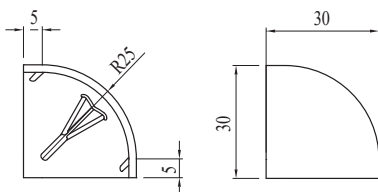

Kodas	Pastaba	Spalva	g
084.310.023	For 084.310.022 - Su 084.310.022 - Para 084.310.022 - Pour 084.310.022 - Für 084.310.022	A	6
084.310.023G	Pour 084.310.022 - Su 084.310.022 - Para 084.310.022 - Pour 084.310.022 - Für 084.310.022	B	6

Polyamide
 Poliamidas
 Poliamida
 Polyamide
 Polyamid

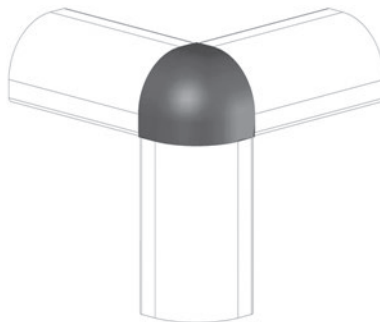



KAMPINIS DANGTELIS 30x30

BH
8
30

TAPPO QUADRO 3 VIE
TA PA PARA ESCUADRA EMBOUT
EQUERRE ABDECKKAPPE FÜR
ECKWINKEL

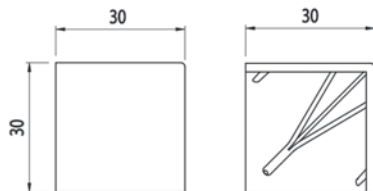

Kodas	Pastaba	Spalva	g
084.310.024	For 084.310.022 - Su 084.310.022 - Para 084.310.022 - Pour 084.310.022 - Für 084.310.022	A	6
084.310.024G	For 084.310.022 -Su 084.310.022 - Para 084.310.022 - Pour 084.310.022 - Für 084.310.022	B	6

Polyamide
Poliamidas
Poliamida
Polyamide
Polyamid

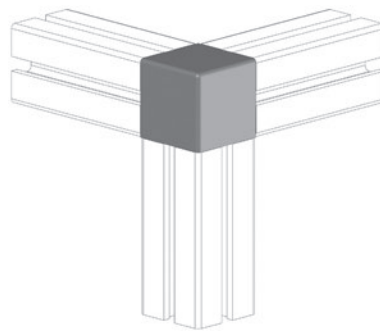

TRIJŲ KRYPČIŲ KAMPAS

BH
10
40

GIUNTO 3 VIE
ESCUADRA 3 VÍAS
EQUERRE 3 VOIES
3-WEGE ECKWINKEL



Kodas	Pastaba	g
084.310.027	Screws included - Komplekte su varžtais - Tornillos incluidos - Vis fournies - Schrauben im Lieferumfang enthalten	22,6

Sandblasted aluminium
Smėliapūte apdorotas aliuminis
Aluminio arenado
Aluminium sablé
Sandgestrahltes Aluminium

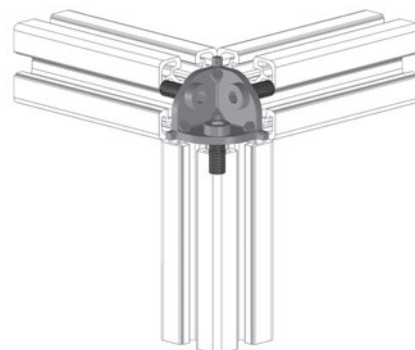
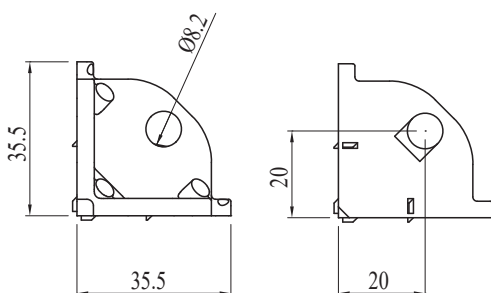



KAMPINIS DANGTELIS 40x40



TAPPO QUADRO 3 VIE
TA PA PARA ESCUADRA EMBOUT EQUERRE
ABDECKKAPPE FÜR ECKWINKEL



Kodas	Pastaba	Spalva	g
084.310.029	For 084.310.027 - DéI 084.310.027 - Para 084.310.027 - Pour 084.310.027 - Für 084.310.022	A	10,8

Polyamide
Poliamidas
Poliamida
Polyamide
Polyamid

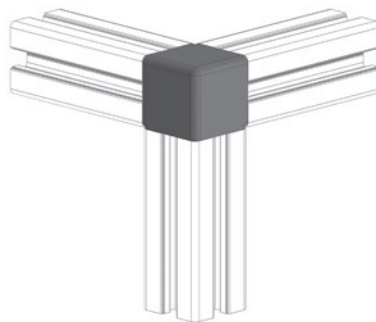
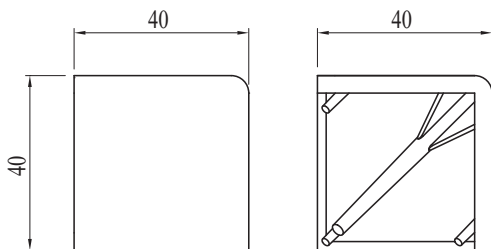

3 KRYPČIŲ KAMPAS-LAIKIKLIS

GIUNTO 3 VIE
ESCUADRA 3 VÍAS
EQUERRE 3 VOIES
3-WEGE ECKWINKEL



Kodas	Pastaba	g
084.310.013	Screws included - Komplekte su varžtais - Tornillos incluidos - Vis fournies - Schrauben im Lieferumfang enthalten	114



Zamak
Zamak
Zamak
Zamak

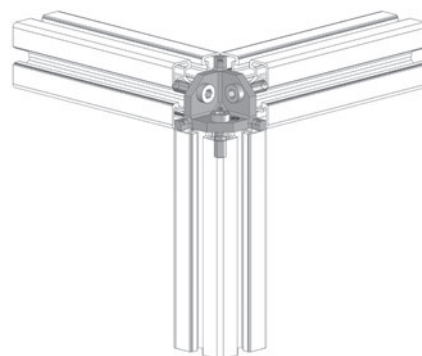
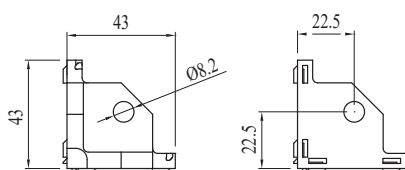



SFERINIS DANGTELIS



TAPPO TONDO 3 VIE
TA PA PARA ESCUADRA EMBOUT
EQUERRE ABDECKKAPPE FÜR
ECKWINKEL

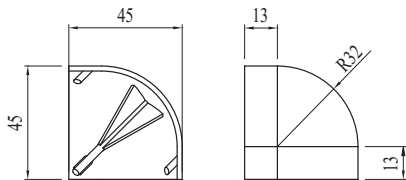

Kodas	Pastaba	Spalva	g
084.310.014	For 084.310.013 - Su 084.310.013 - Para 084.310.013 - Pour 084.310.013 - Für 084.310.013	A	9
084.310.014G	For 084.310.013 - Su 084.310.013 - Para 084.310.013 - Pour 084.310.013 - Für 084.310.013	B	9

Polyamide
Poliamidas
Poliamida
Polyamide
Polyamid

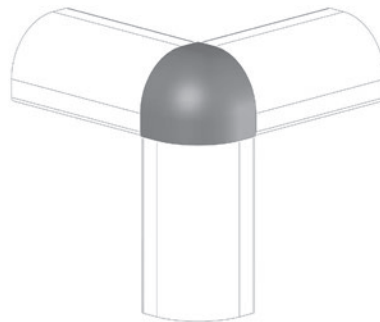

KAMPINIS DANGTELIS



TAPPO QUADRO 3 VIE
TA PA PARA ESCUADRA
EMBOUT EQUERRE
ABDECKKAPPE FÜR
ECKWINKEL

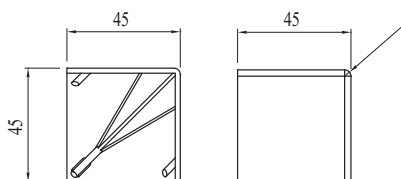

Kodas	Pastaba	Spalva	g
084.310.015	For 084.310.013 - Su 084.310.013 - Para 084.310.013 - Pour 084.310.013 - Für 084.310.013	A	14
084.310.015G	For 084.310.013 - Su 084.310.013 - Para 084.310.013 - Pour 084.310.013 - Für 084.310.013	B	14

Polyamide
Poliamidas
Poliamida
Polyamide
Polyamid

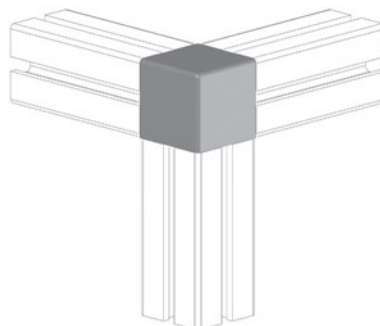



SUKAMA JUNGTIS, 40x40



GIUNTO SNODATO 40X40
ARTICULACIÓN GRADUABLE 40x40
ARTICULATION 40x40
GELENK 40x40



Kodas	Pastaba	g
084.311.021	With orientable anti-rotation system. - Su reguliuojama apsaugos nuo sukimosi sistema. - Con sistema antirrotación orientable. - Avec système anti-rotation orientable. - Mit verstellbarer Verdrehsicherung.	146

Sandblasted aluminium
Smėliapūte apdorotas aluminis
Aluminio arenado
Aluminium sablé
Sandgestrahltes Aluminium

Use 084.312.003 bushings
Naudojamos įvorės 084.312.003
Usar casquillos 084.312.003
Utiliser bagues 084.312.003
Buchsen 084.312.003 verwenden

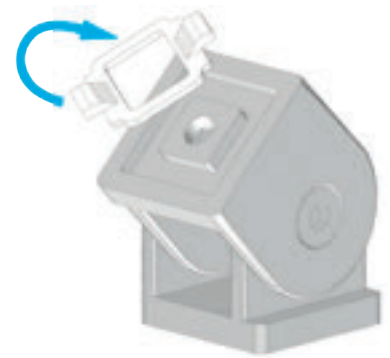
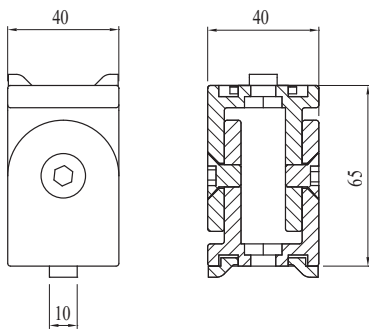

SUKAMA JUNGTIS, 45x45



GIUNTO SNODATO 45X45
ARTICULACIÓN GRADUABLE 45x45
ARTICULATION 45x45
GELENK 45x45

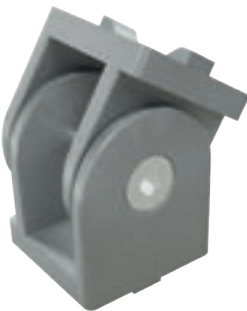

Kodas	Pastaba	g
084.311.016	With orientable anti-rotation system. - Su reguliuojama apsaugos nuo sukimosi sistema. - Con sistema antirrotación orientable. - Avec système anti-rotation orientable. - Mit verstellbarer Verdrehsicherung.	210

Sandblasted aluminium
Smėliapūte apdorotas aluminis
Aluminio arenado
Aluminium sablé
Sandgestrahltes Aluminium

Use 084.312.003 bushings
Naudojamos įvorės 084.312.003
Usar casquillos 084.312.003
Utiliser bagues 084.312.003
Buchsen 084.312.003 verwenden

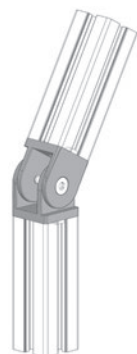
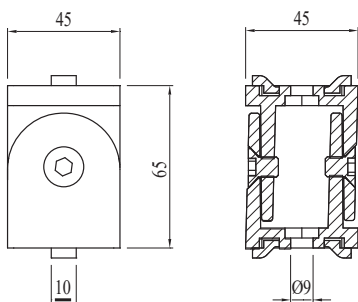



SUKAMA JUNGTTIS 45x45, REGULIUOJAMA

GIUNTO SNODATO 45X45 FRIZIONABILE
 ARTICULACIÓN GRADUABLE 45x45 AJUSTABLE
 ARTICULATION 45x45 RÉGLABLE
 GELENK 45x45, EINSTELLBAR



Kodas	Pastaba	g
084.311.020	With orientable anti-rotation system - Su reguliuojama apsaugos nuo sukimosi sistema. - Con sistema antirrotación orientable - Avec système anti-rotation orientable - Mit verstellbarer Verdrehsicherung	230

Sandblasted aluminium
 Smėliapūte apdorotas aluminis
 Aluminio arenado
 Aluminium sablé
 Sandgestrahltes Aluminium

Use 084.312.003 bushings
 Naudojamos įvorės 084.312.003
 Usar casquillos 084.312.003
 Utiliser bagues 084.312.003
 Buchsen 084.312.003 verwenden

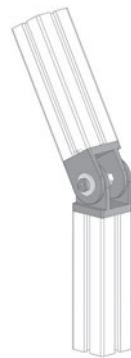
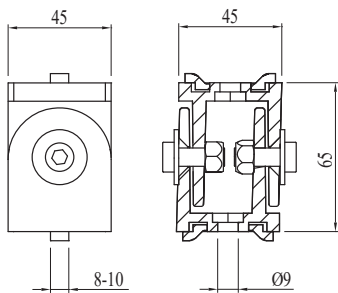

SUKAMA JUNGTTIS 45x45, SU FIKSAVIMO SVIRTIMI

GIUNTO SNODATO 45X45 A LEVA
 ARTICULACIÓN GRADUABLE 45x45 CON PALANCA
 ARTICULATION 45x45 AVEC BLOCAGE
 GELENK 45x45 MIT KLEMMHEBEL



Kodas	Pastaba	g
084.311.019	With orientable anti-rotation system - Su reguliuojama apsaugos nuo sukimosi sistema. - Con sistema antirrotación orientable - Avec système anti-rotation orientable - Mit verstellbarer Verdrehsicherung	240

Sandblasted aluminium
 Smėliapūte apdorotas aluminis
 Aluminio arenado
 Aluminium sablé
 Sandgestrahltes Aluminium

Use 084.312.003 bushings
 Naudojamos įvorės 084.312.003
 Usar casquillos 084.312.003
 Utiliser bagues 084.312.003
 Buchsen 084.312.003 verwenden

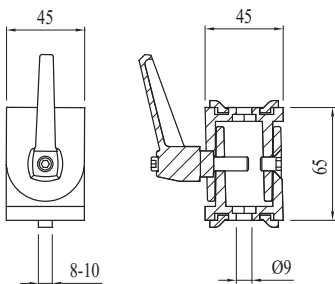



SUKAMA JUNGTIS 40x80



GIUNTO SNODATO 40X80
ARTICULACIÓN GRADUABLE
40x80 ARTICULATION 40x80
GELENK 40x80



Kodas	Pastaba	g
084.311.011	With orientable anti-rotation system - Su reguliuojama apsaugos nuo sukimosi sistema.- Con sistema antirrotación - Avec système anti-rotation - Mit Verdrehsicherung	997

Zamak
Z a m a k
Z a m a k
Zamak

Use 084.312.003 bushings
Naudojamos įvorės 084.312.003
Usar casquillos 084.312.003
Utiliser bagues 084.312.003
Buchsen 084.312.003 verwenden

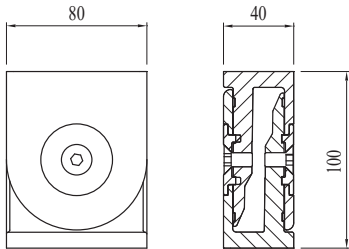

SUKAMA JUNGTIS 40x90



GIUNTO SNODATO 45X90
ARTICULACIÓN GRADUABLE
45x90 ARTICULATION 45x90
GELENK 45x90



Kodas	Pastaba	g
084.311.012	With anti-rotation system - Su reguliuojama apsaugos nuo sukimosi sistema - Con sistema antirrotación - Avec système anti-rotation - Mit Verdrehsicherung	1120

Aluminium
Alluminis
Aluminio
Aluminium
Aluminium

Use 084.312.003 bushings
Naudojamos įvorės 084.312.003 Usar
casquillos 084.312.003 Utiliser
bagues 084.312.003 Buchsen
084.312.003 verwenden

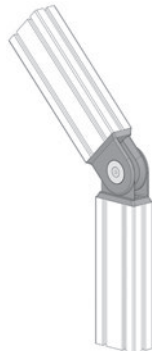
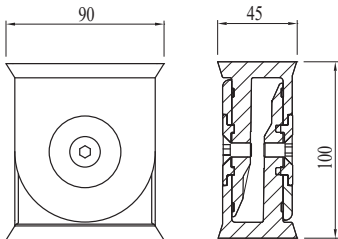

**JUNGTIES PLOKŠTĖ 40x40**

PIASTRA DI FISSAGGIO 40X40
 PLETINA DE UNIÓN 40x40
 PLATINE D'ASSEMBLAGE 40x40
 BEFESTIGUNGSPLATTE 40x40

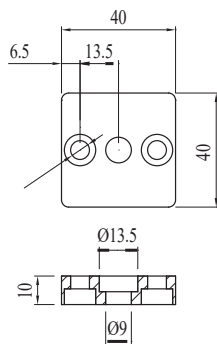
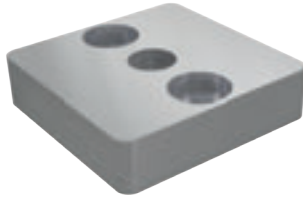

Kodas	Pastaba	g
084.308.003	For 40x40 profile - Profiliui 40x40 - Para perfil 40x40 - Pour profilé 40x40 - Für Profil 40x40	40

Anodised aluminium
 Anodizuotas aliuminis
 Aluminium anodisé
 Eloxiertes Aluminium

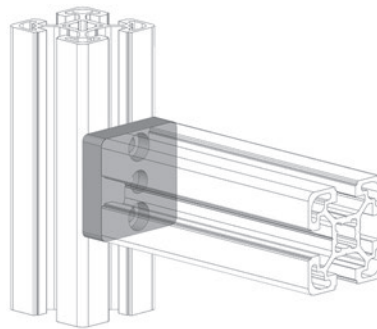
**JUNGTIES PLOKŠTĖ 45x45**

PIASTRA DI FISSAGGIO 45X45
 PLETINA DE UNIÓN 45x45
 PLATINE D'ASSEMBLAGE 45x45
 BEFESTIGUNGSPLATTE 45x45

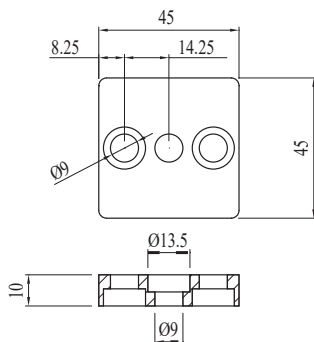
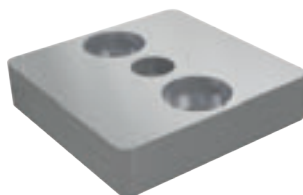

Kodas	Pastaba	g
084.308.001	For 45x45 profile - Profiliui 45x45 - Para perfil 45x45 - Pour profilé 45x45 - Für Profil 45x45	45

Anodised aluminium
 Anodizuotas aliuminis
 Aluminium anodisé
 Eloxiertes Aluminium

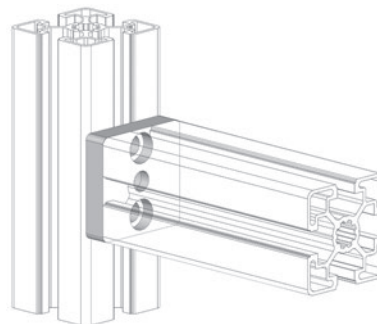



JUNGTIES PLOKŠTĖ 40x80

BH
10
40

PIASTRA DI FISSAGGIO 40X80
PLETINA DE UNIÓN 40x80
PLATINE D'ASSEMBLAGE 40x80
BEFESTIGUNGSPLATTE 40x80

Kodas	Pastaba	g
084.308.004	For 40x80 profile - Profiliui 40x80 - Para perfil 40x80 - Pour profilé 40x80 - Für Profil 40x80	80

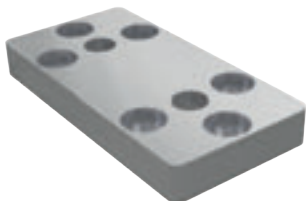

Anodised aluminium
Anodizuotas aliuminis
Aluminium anodisé
Eloxiertes Aluminium

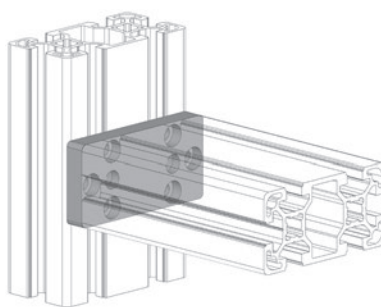
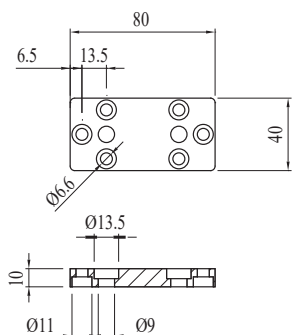

JUNGTIES PLOKŠTĖ 45x90

BH L
10
45

BH H
10
45

PIASTRA DI FISSAGGIO 45X90
PLETINA DE UNIÓN 45x90
PLATINE D'ASSEMBLAGE 45x90
BEFESTIGUNGSPLATTE 45x90

Kodas	Pastaba	g
084.308.002	For 45x90 profile - Profiliui 45x90 - Para perfil 45x90 - Pour profilé 45x90 - Für Profil 45x90	85

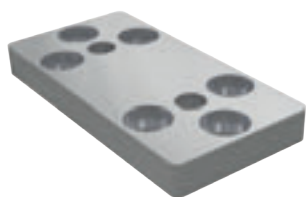

Anodised aluminium
Anodizuotas aliuminis
Aluminium anodisé
Eloxiertes Aluminium

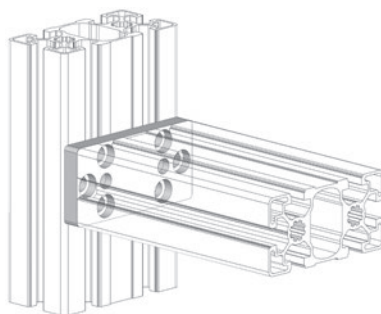
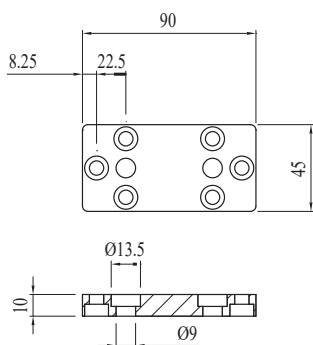

**JUNGTIES PLOKŠTĖ 50x50**

PIASTRA DI FISSAGGIO 50X50
 PLETINA DE UNIÓN 50x50
 PLETINE D'ASSEMBLAGE 50x50
 BEFESTIGUNGSPLATTE 50x50

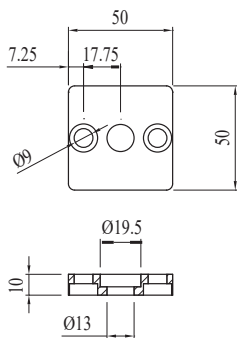
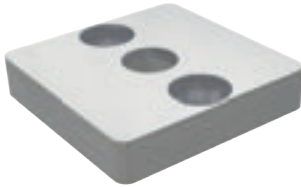

Kodas	Pastaba	g
084.308.006	For 50x50 profile - Profiliui 50x50 - Para perfil 50x100 - Pour profilé 50x50 - Für profil 50x50	60

Anodised aluminium
 Anodizuotas aliuminis
 Aluminium anodisé
 Eloxiertes Aluminium

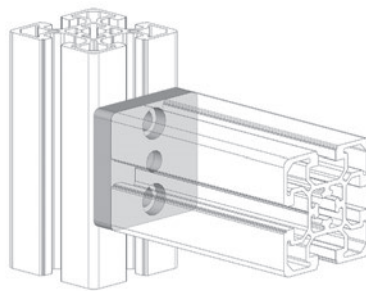
**JUNGTIES PLOKŠTĖ 50x100**

PIASTRA DI FISSAGGIO 50X100
 PLETINA DE UNIÓN 50x100
 PLETINE D'ASSEMBLAGE 50x100
 BEFESTIGUNGSPLATTE 50x100

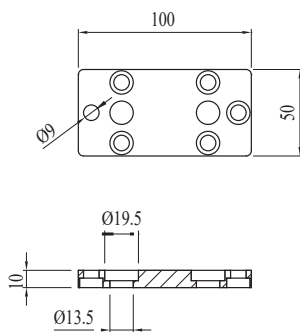

Kodas	Pastaba	g
084.308.007	For 50x100 profile - Profiliui 50x100 - Para perfil 50x100 - Pour profilé 50x100 - Für Profil 50x100	110

Anodised aluminium
 Anodizuotas aliuminis
 Aluminium anodisé
 Eloxiertes Aluminium

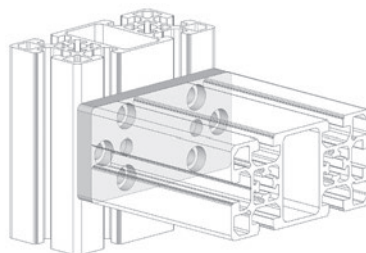



45° KAMPO JUNGTIS



CONNETTORE 45°
UNIÓN 45°
ELÉMENT DE JONCTION 45°
WINKELVERBINDER 45°

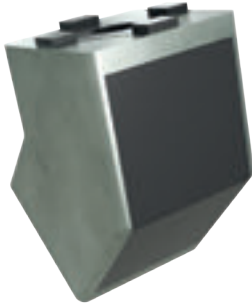

Kodas	Pastaba	g
084.305.050	For 30x30 profiles - Profiliui 30x30 - Para perfi-les 30x30 - Pour profilés 30x30 - Für 30x30 Profile	50

Zamak
Z a m a
Z a m a k
Z a m a k
Zamak

Black polyamide
Juodas poliamidas
Poliamida color negro
Polyamide noir Polyamid
schwarz

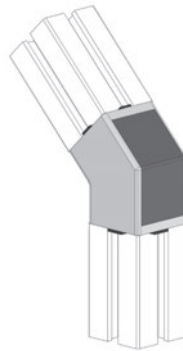
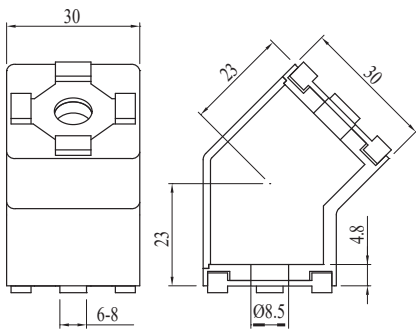

45° KAMPO JUNGTIS



GIUNTO 45°
UNIÓN 45°
ELÉMENT DE JONCTION 45°
WINKELVERBINDER 45°



Kodas	Pastaba	g
084.305.051	For 40x40 profiles - Profiliui 40x40 - Para perfi-les 40x40 - Pour profilés 40x40 - Für 40x40 Profile	125

Zamak
Z a m a
Z a m a k
Z a m a k
Zamak

Black polyamide
Juodas poliamidas
Poliamida color negro
Polyamide noir Polyamid
schwarz

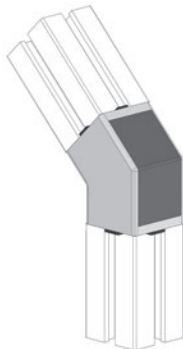
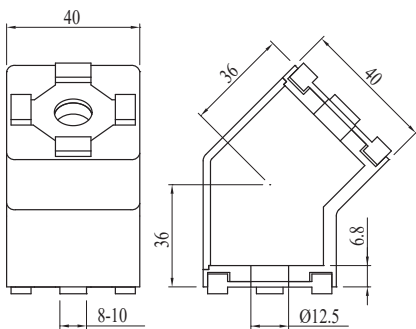



45° KAMPO JUNGTTIS

GIUNTO 45°
UNIÓN 45°
ELÉMENT DE JONCTION 45°
WINKELVERBINDER 45°



Kodas	Pastaba	g
084.305.052	Per profili 45x45 - Profiliui 45x45 - Para perfí-les 45x45 - Pour profilés 45x45 - Für 45x45 Profile	154



Zamak
Z a m a
Z a m a k
Z a m a k
Zamak

Black polyamide
Juodas poliamidas
Poliamida color negro
Polyamide noir Polyamid
schwarz

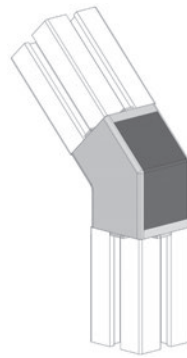
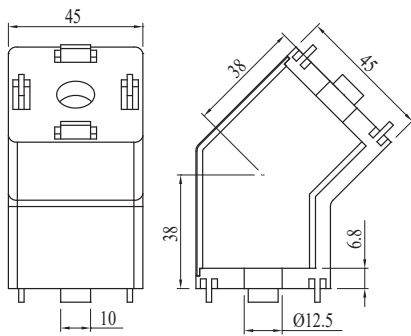



13x22 LAIKIKLIS

ANGOLARE 13X22
 ESCUADRA 13X22
 EQUERRE 13X22
 ALUWINKEL 13X22

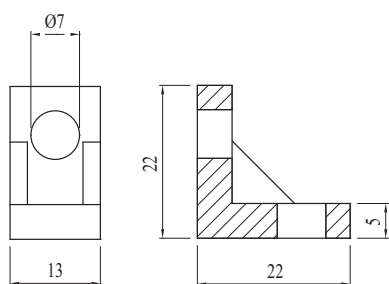

Kodas	Pastaba	g
084.305.006	Assembly with M6x12 screws, not included - Tvirtinimas M6x12 varžtais, nepridedami - Montaje con tornillos M6x12, no incluidos - Montage avec vis M6x12 non fournies - Montage mit Schrauben M6x12 (nicht im Lieferumfang enthalten)	6

Sandblasted aluminium
 Smėliapūte apdorotas aliuminis
 Aluminio arenado
 Aluminium sablé
 Sandgestrahltes Aluminium

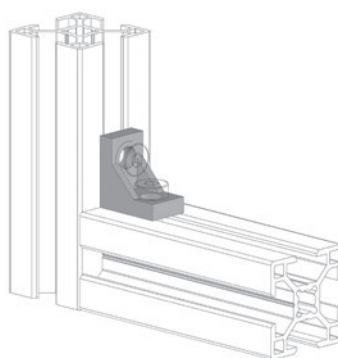

18x18 LAIKIKLIS

ANGOLARE 18X18
 ESCUADRA 18X18
 EQUERRE 18X18
 ALUWINKEL 18X18

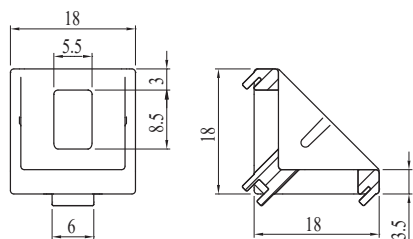

Kodas	Pastaba	g
084.305.032	Assembly with M5x12 screws, not included - Tvirtinimas M5x12 varžtais, nepridedami - Montaje con tornillos M5x12, no incluidos - Montage avec vis M5x12 non fournies - Montage mit Schrauben M5x12 (nicht im Lieferumfang enthalten)	5

Sandblasted aluminium
 Smėliapūte apdorotas aliuminis
 Aluminio arenado
 Aluminium sablé
 Sandgestrahltes Aluminium

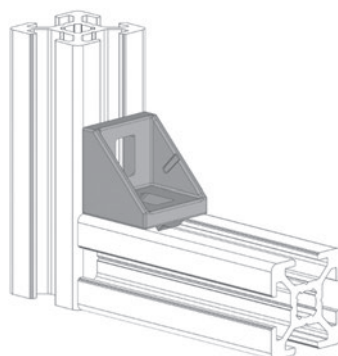

Cap - Dangtelis - Tapòn - Embout - Abdeckkappe			
Kodas	Medž.	g	Sp.
084.206.007	PA	3	A
084.206.007G	PA	3	B



27x27 LAIKIKLIS

ANGOLARE 27X27
 ESCUADRA 27X27
 EQUERRE 27X27
 ALUWINKEL 27X27

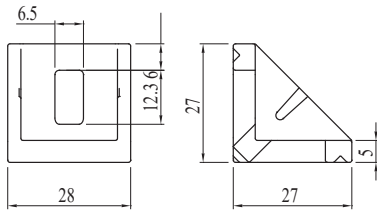
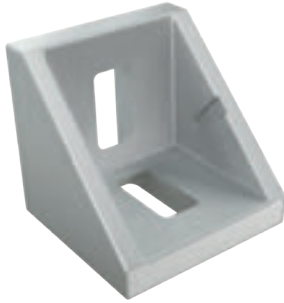

Kodas	Pastaba	g
084.305.010	Assembly with M6x16 screws, not included - Tvirtinimas M6x16 varžtais, nepridedami - Montage con tornillos M6x16, no incluidos - Montage avec vis M6x16 non fournies - Montage mit Schrauben M6x16 (nicht im Lieferumfang enthalten)	29

Sandblasted aluminium
 Smėliapūte apdorotas aliuminis
 Aluminio arenado
 Aluminium sablé
 Sandgestrahltes Aluminium

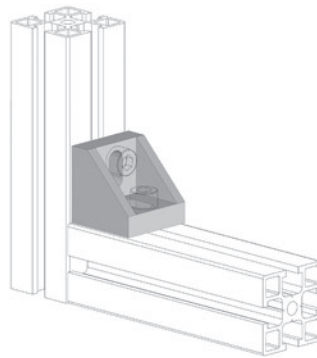

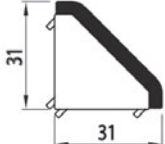
Cap - Dangtelis - Tapòn - Embout - Abdeckkappe			
			
Kodas	Medž.	g	Sp.
084.206.008	PA	6	A
084.206.008G	PA	6	B

27x27 LAIKIKLIS

ANGOLARE 27X27
 ESCUADRA 27X27
 EQUERRE 27X27
 ALUWINKEL 27X27

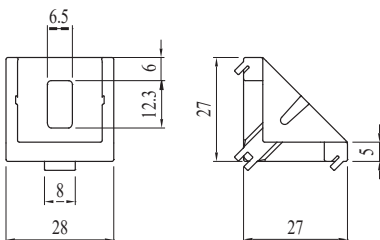
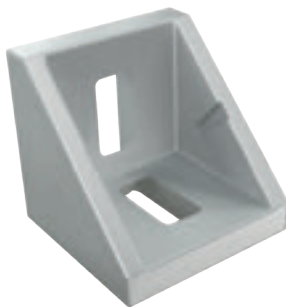

Kodas	Pastaba	g
084.305.036	Assembly with M6x16 screws, not included - Tvirtinimas M6x16 varžtais, nepridedami- Montage con tornillos M6x16, no incluidos - Montage avec vis M6x16 non fournies - Montage mit Schrauben M6x16 (nicht im Lieferumfang enthalten)	19

Sandblasted aluminium
 Smėliapūte apdorotas aliuminis
 Aluminio arenado
 Aluminium sablé
 Sandgestrahltes Aluminium

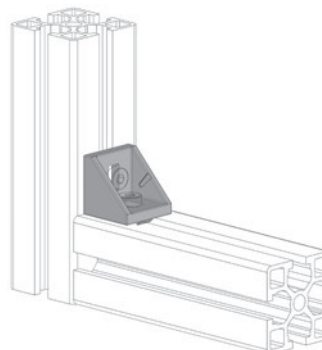

Cap - Dangtelis - Tapòn - Embout - Abdeckkappe			
			
Kodas	Medž.	g	Sp.
084.206.008	PA	6	A
084.206.008G	PA	6	B



27x59 LAIKIKLIS

ANGOLARE 27X59
 ESCUADRA 27X59
 EQUERRE 27X59
 ALUWINKEL 27X59

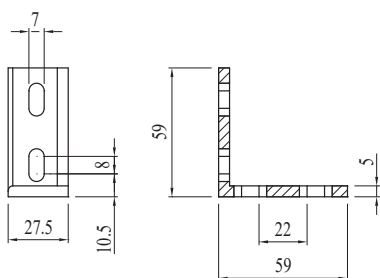

Kodas	Pastaba	g
084.305.007	Assembly with M6x16 screws, not included - Tvirtinimas M6x16 varžtais, nepridedami - Montaje con tornillos M6x16, no incluidos - Montage avec vis M6x16 non fournies - Montage mit Schrauben M6x16 (nicht im Lieferumfang enthalten)	46

Sandblasted aluminium
 Smėliapūte apdorotas aliuminis
 Aluminio arenado
 Aluminium sablé
 Sandgestrahltes Aluminium

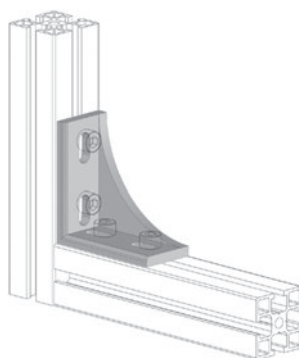

59x59 LAIKIKLIS

ANGOLARE 59X59
 ESCUADRA 59X59
 EQUERRE 59X59
 ALUWINKEL 59X59

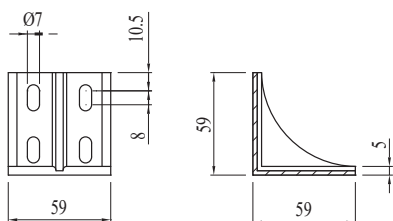

Kodas	Pastaba	g
084.305.008	Assembly with M6x16 screws, not included - Tvirtinimas M6x16 varžtais, nepridedami - Montaje con tornillos M6x16, no incluidos - Montage avec vis M6x16 non fournies - Montage mit Schrauben M6x16 (nicht im Lieferumfang enthalten)	93

Sandblasted aluminium
 Smėliapūte apdorotas aliuminis
 Aluminio arenado
 Aluminium sablé
 Sandgestrahltes Aluminium

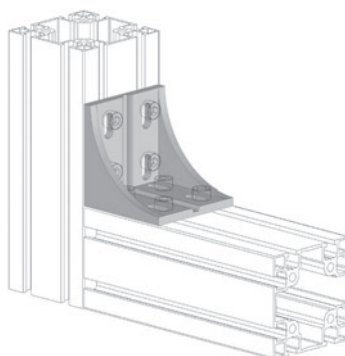

**18x40 LAIKIKLIS**

ANGOLARE 18X40
 ESCUADRA 18X40
 EQUERRE 18X40
 ALUWINKEL 18X40

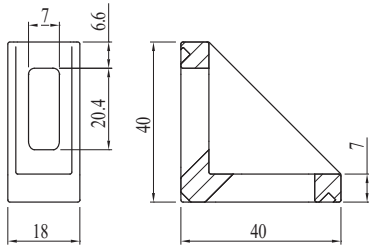

Kodas	Pastaba	g
084.305.001	Assembly with M6 screws, not included - Tvirtinimas M6 varžtais, nepridedami - Montaje con tornillos M6, no incluidos - Montage avec vis M6 non fournies - Montage mit Schrauben M6 (nicht im Lieferumfang enthalten)	20

Sandblasted aluminium
 Smėliapūte apdorotas aliuminis
 Aluminio arenado
 Aluminium sablé
 Sandgestrahltes Aluminium

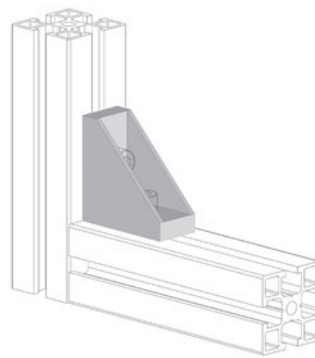

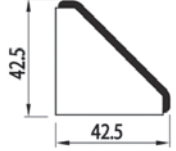
Cap - Dangtelis - Tapòn - Embout - Abdeckkappe			
			
Kodas	Medž.	g	Sp.
084.206.001	PA	3	A
084.206.001G	PA	3	B

18x40 LAIKIKLIS

ANGOLARE 18X40
 ESCUADRA 18X40
 EQUERRE 18X40
 ALUWINKEL 18X40

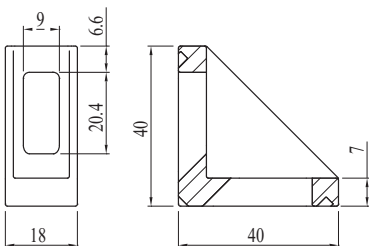

Kodas	Pastaba	g
084.305.041	Assembly with M8x20 screws, not included - Tvirtinimas M8x20 varžtais, nepridedami - Montaje con tornillos M8x20, no incluidos - Montage avec vis M8x20 non fournies - Montage mit Schrauben M8x20 (nicht im Lieferumfang enthalten)	20

Sandblasted aluminium
 Smėliapūte apdorotas aliuminis
 Aluminio arenado
 Aluminium sablé
 Sandgestrahltes Aluminium

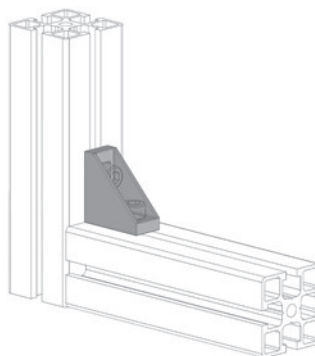

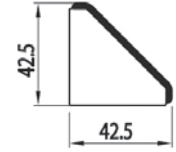
Cap - Dangtelis - Tapòn - Embout - Abdeckkappe			
			
Kodas	Medž.	g	Sp.
084.206.001	PA	3	A
084.206.001G	PA	3	B



25x40 LAIKIKLIS

ANGOLARE 25X40
 ESCUADRA 25X40
 EQUERRE 25X40
 ALUWINKEL 25X40

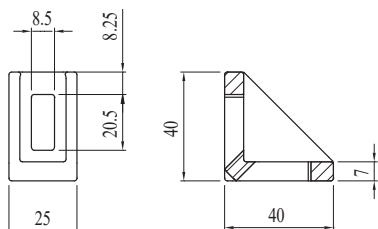

Kodas	Pastaba	g
084.305.002	Assembly with M8x20 screws, not included - Tvirtinimas M8x20 varžtais, nepridedami - Montage con tornillos M8x20, no incluidos - Montage avec vis M8x20 non fournies - Montage mit Schrauben M8x20 (nicht im Lieferumfang enthalten)	30

Sandblasted aluminium
 Smėliapūte apdorotas aliuminis
 Aluminio arenado
 Aluminium sablé
 Sandgestrahltes Aluminium

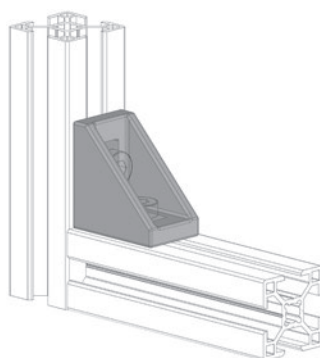

Cap - Dangtelis - Tapòn - Embout - Abdeckkappe			
Kodas	Medž.	g	Sp.
084.206.002	PA	4	A
084.206.002G	PA	4	B

25x40 LAIKIKLIS

ANGOLARE 25X40
 ESCUADRA 25X40
 EQUERRE 25X40
 ALUWINKEL 25X40

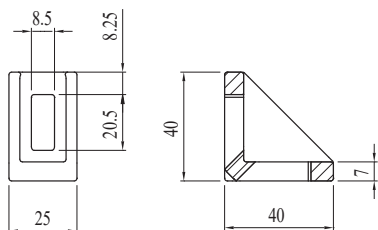

NEW

Kodas	Pastaba	g
084.305.059	Assembly with M8x20 screws, not included - Tvirtinimas M8x20 varžtais, nepridedami - Montage con tornillos M8x20, no incluidos - Montage avec vis M8x20 non fournies - Montage mit Schrauben M8x20 (nicht im Lieferumfang enthalten)	17

PA6+GF

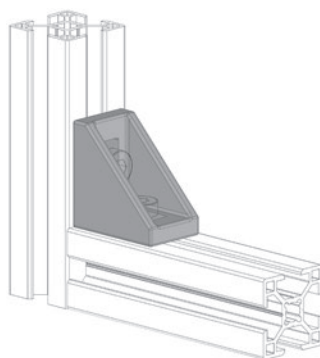

Cap - Dangtelis - Tapòn - Embout - Abdeckkappe			
Kodas	Medž.	g	Sp.
084.206.002	PA	4	A
084.206.002G	PA	4	B

**25x80 LAIKIKLIS**

ANGOLARE 25X80
 ESCUADRA 25X80
 EQUERRE 25X80
 ALUWINKEL 25X80

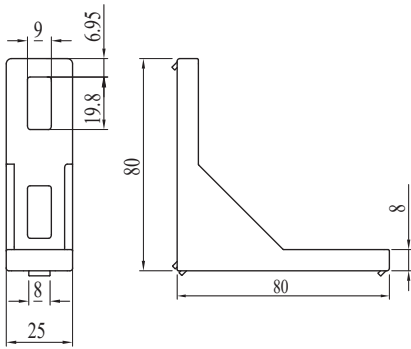

Kodas	Pastaba	g
084.305.044	Assembly with M8x20 screws, not included - Tvirtinimas M8x20 varžtais, nepridedami - Montaje con tornillos M8x20, no incluidos - Montage avec vis M8x20 non fournies - Montage mit Schrauben M8x20 (nicht im Lieferumfang enthalten)	63

Sandblasted aluminium
 Smėliapūte apdorotas aliuminis
 Aluminio arenado
 Aluminium sablé
 Sandgestrahltes Aluminium

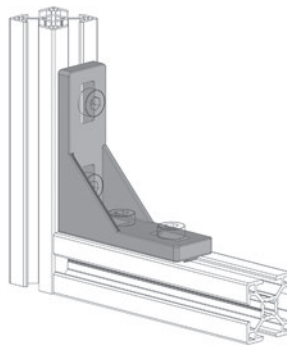
**25x80 LAIKIKLIS**

ANGOLARE 25X80
 ESCUADRA 25X80
 EQUERRE 25X80
 ALUWINKEL 25X80

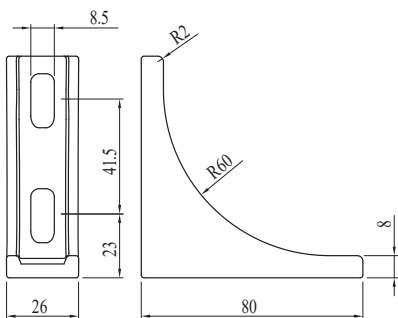
**NEW**

Kodas	Pastaba	g
084.305.060	Assembly with M8x20 screws, not included -Tvirtinimas M8x20 varžtais, nepridedami - Montaje con tornillos M8x20, no incluidos - Montage avec vis M8x20 non fournies - Montage mit Schrauben M8x20 (nicht im Lieferumfang enthalten)	31

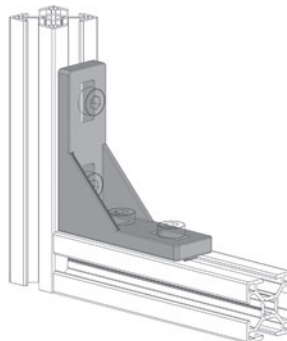
PA6+GF



38x38 LAIKIKLIS

ANGOLARE 38X38
 ESCUADRA 38X38
 EQUERRE 38X38
 ALUWINKEL 38X38

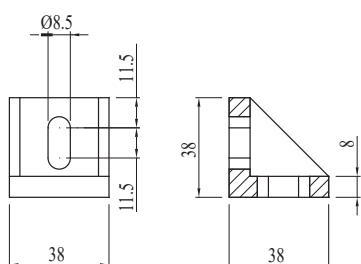

Kodas	Pastaba	g
084.305.009	Assembly with M8x20 screws, not included - Tvirtinimas M8x20 varžtais, nepridedami - Montaje con tornillos M8x20, no incluidos - Montage avec vis M8x20 non fournies - Montage mit Schrauben M8x20 (nicht im Lieferumfang enthalten)	50

Sandblasted aluminium
 Smėliapūte apdorotas aliuminis
 Aluminio arenado
 Aluminium sablé
 Sandgestrahltes Aluminium

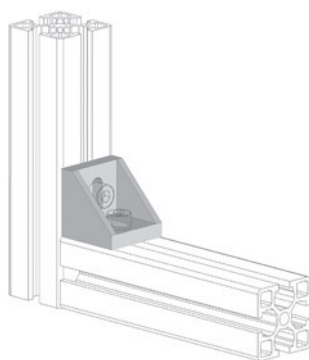

38x38 LAIKIKLIS

ANGOLARE 38X38
 ESCUADRA 38X38
 EQUERRE 38X38
 ALUWINKEL 38X38

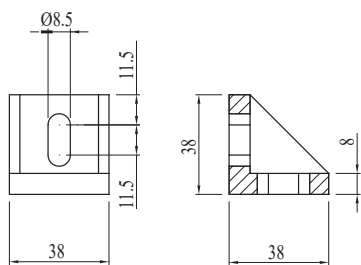
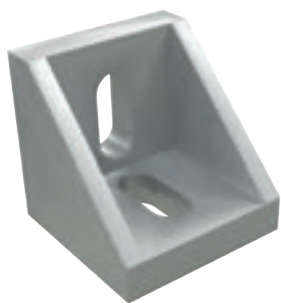

Kodas	Pastaba	g
084.305.009T	Assembly with M8x20 screws, not included - Tvirtinimas M8x20 varžtais, nepridedami - Montaje con tornillos M8x20, no incluidos - Montage avec vis M8x20 non fournies - Montage mit Schrauben M8x20 (nicht im Lieferumfang enthalten)	50

Tumbled zamak
 Vibraciniu būdu apdorotas Zamak lydinys
 Zamak vibroacabado
 Zamak tribofini
 Gleitgeschliffene Zamak-Legierung

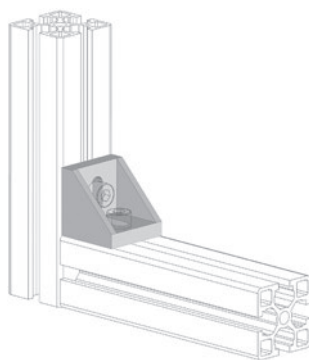

**30x30 LAIKIKLIS**

ANGOLARE 30X30
 ESCUADRA 30X30
 EQUERRE 30X30
 ALUWINKEL 30X30

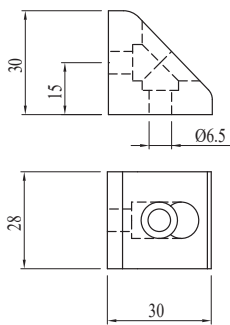
**NEW**

Kodas	Pastaba	g
084.305.058	Assembly with M6X16 screws, not included - Tvirtinimas M6x16 varžtais, nepridedami - Montaje con tornillos M6X16, no incluidos - Montage avec vis M6X16 non fournies - Montage mit Schrauben M6X16 (nicht im Lieferumfang enthalten)	41

Tumbled aluminium
 Aliuminis vibraciniu būdu apdorotas
 Aluminio vibroacabado
 Aluminium tribofini
 Gleitgeschliffene Aluminium

40x40 LAIKIKLIS

ANGOLARE 40X40
 ESCUADRA 40X40
 EQUERRE 40X40
 ALUWINKEL 40X40

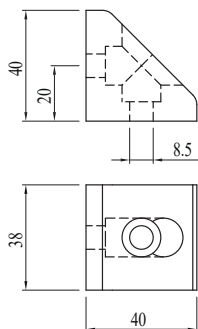

Kodas	Pastaba	g
084.305.054	Assembly with M8x20 screws, not included - Tvirtinimas M8x20 varžtais, nepridedami - Montaje con tornillos M8x20, no incluidos - Montage avec vis M8x20 non fournies - Montage mit Schrauben M8x20 (nicht im Lieferumfang enthalten)	99

Sandblasted aluminium
 Smėliapūte apdorotas aluminis
 Aluminio arenado
 Aluminium sablé
 Sandgestrahltes Aluminium



36x36 LAIKIKLIS

ANGOLARE 36X36
ESCUADRA 36X36
EQUERRE 36X36
ALUWINKEL 36X36

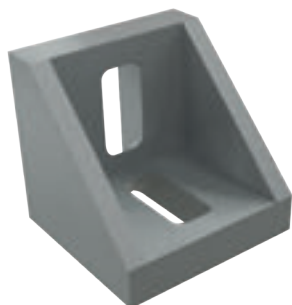

Kodas	Pastaba	g
084.305.040	Assembly with M8x20 screws, not included - Tvirtinimas M8x20 varžtais, nepridedami - Tvirtinimas M8x20 varžtais, nepridedami - Montage avec vis M8x20 non fournies - Montage mit Schrauben M8x20 nicht im Lieferumfang enthalten	28

Sandblasted aluminium
Smėliapūte apdorotas aliuminis
Aluminio arenado
Aluminium sablé
Sandgestrahltes Aluminium

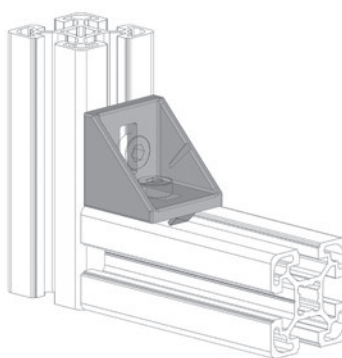
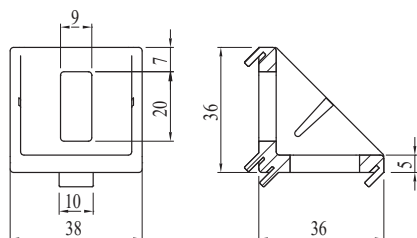

Cap - Dangtelis - Tapòn - Embout - Abdeckkappe			
Kodas	Medž.	g	Sp.
084.206.009	PA	9	A

36x36 LAIKIKLIS

ANGOLARE 36X36
ESCUADRA 36X36
EQUERRE 36X36
ALUWINKEL 36X36



Kodas	Pastaba	g
084.305.040T	Assembly with M8x20 screws, not included - Tvirtinimas M8x20 varžtais, nepridedami - Montage con tornillos M8x20, no incluidos - Montage avec vis M8x20 non fournies - Montage mit Schrauben M8x20 nicht im Lieferumfang enthalten	28

Tumbled aluminium
Alluminiso vibraciniu būdu apdorotas vibraciniu būdu
suformuotas
Aluminio vibroacabado
Aluminium tribofini

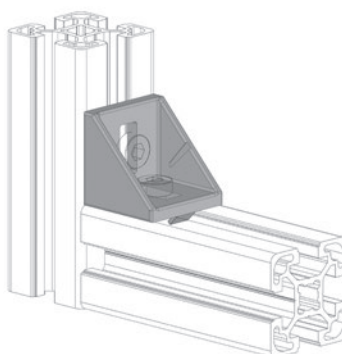
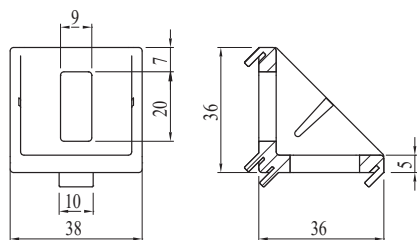

Cap - Dangtelis - Tapòn - Embout - Abdeckkappe			
Kodas	Medž.	g	Sp.
084.206.009	PA	9	A

**37x78 LAIKIKLIS**

ANGOLARE 37X78
 ESCUADRA 37X78
 EQUERRE 37X78
 ALUWINKEL 37X78

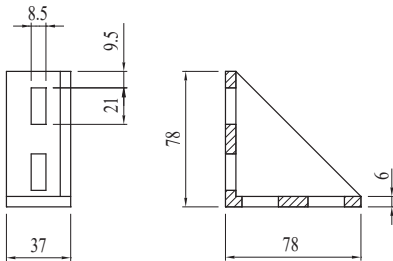

Kodas	Pastaba	g
084.305.024	Assembly with M8x20 screws, not included - Tvirtinimas M8x20 varžtais, nepridedami - Montaje con tornillos M8x20, no incluidos - Montage avec vis M8x20 non fournies - Montage mit Schrauben M8x20 (nicht im Lieferumfang enthalten)	115

Sandblasted aluminium
 Smėliapūte apdorotas aliuminis
 Aluminio arenado
 Aluminium sablé
 Sandgestrahltes Aluminium

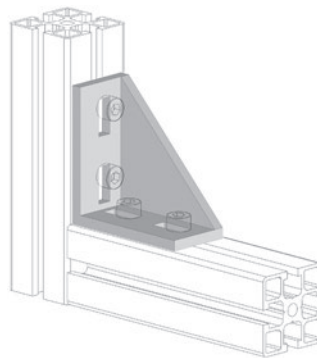
**37x78 LAIKIKLIS**

ANGOLARE 37X78
 ESCUADRA 37X78
 EQUERRE 37X78
 ALUWINKEL 37X78

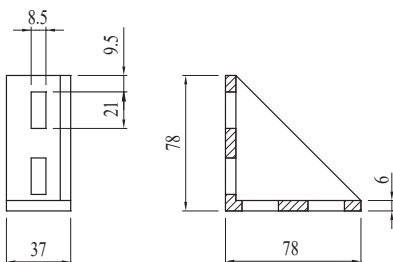

Kodas	Pastaba	g
084.305.024T	Assembly with M8x20 screws, not included - Tvirtinimas M8x20 varžtais, nepridedami - Montaje con tornillos M8x20, no incluidos - Montage avec vis M8x20 non fournies - Montage mit Schrauben M8x20 (nicht im Lieferumfang enthalten)	115

Tumbled zamak
 Zamak vibraciniu būdu suformuotas
 Zamak vibroacabado
 Zamak tribofini
 Gleitgeschliffene Zamak-Legierung

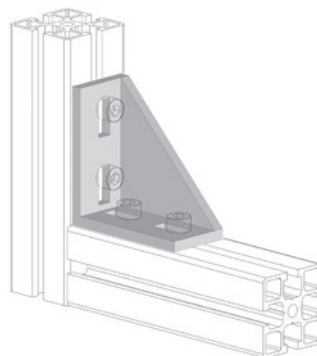



78x78 LAIKIKLIS

ANGOLARE 78X78
 ESCUADRA 78X78
 EQUERRE 78X78
 ALUWINKEL 78X78

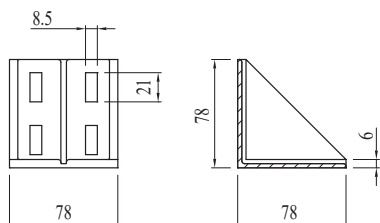

Kodas	Pastaba	g
084.305.022	Assembly with M8x20 screws, not included - Tvirtinimas M8x20 varžtais, nepridedami - Montaje con tornillos M8x20, no incluidos - Montage avec vis M8x20 non fournies - Montage mit Schrauben M8x20 (nicht im Lieferumfang enthalten)	234

Sandblasted aluminium
 Smėliapūte apdorotas aliuminis
 Aluminio arenado
 Aluminium sablé
 Sandgestrahltes Aluminium

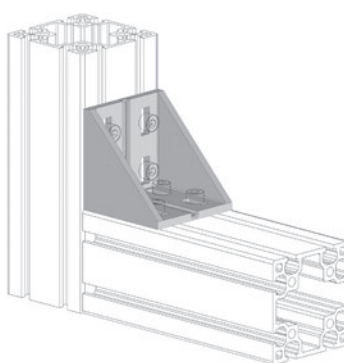

43x43 LAIKIKLIS

ANGOLARE 43X43
 ESCUADRA 43X43
 EQUERRE 43X43
 ALUWINKEL 43X43

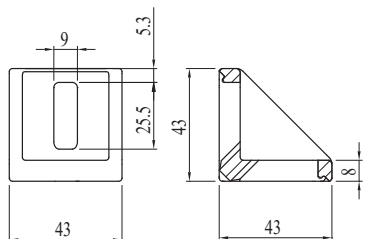

Kodas	Pastaba	g
084.305.003	Assembly with M8x20 screws, not included - Tvirtinimas M8x20 varžtais, nepridedami - Montaje con tornillos M8x20, no incluidos - Montage avec vis M8x20 non fournies - Montage mit Schrauben M8x20 (nicht im Lieferumfang enthalten)	60

Sandblasted aluminium
 Smėliapūte apdorotas aliuminis
 Aluminio arenado
 Aluminium sablé
 Sandgestrahltes Aluminium

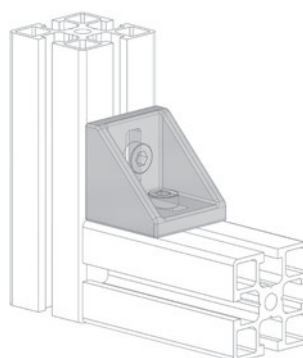

Cap - Dangtelis - Tapòn - Embout - Abdeckkappe			
Kodas	Medž.	g	Sp.
084.206.003	PA	7	A
084.206.003G	PA	7	B



43x43 LAIKIKLIS

ANGOLARE 43X43
ESCUADRA 43X43
EQUERRE 43X43
ALUWINKEL 43X43

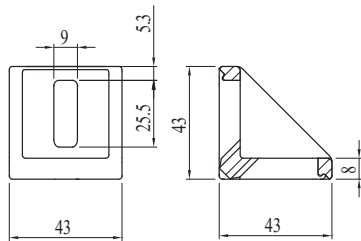

Kodas	Pastaba	g
084.305.003T	Assembly with M8x20 screws, not included - Tvirtinimas M8x20 varžtais, nepridedami - Montage con tornillos M8x20, no incluidos - Montage avec vis M8x20 non fournies - Montage mit Schrauben M8x20 (nicht im Lieferumfang enthalten)	60

Tumbled zamak
Zamak vibraciniu būdu suformuotas
Zamak vibroacabado
Zamak tribofini
Gleitgeschliffene Zamak-Legierung

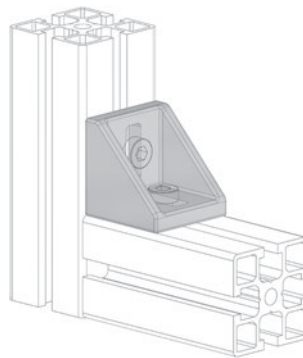

Cap - Dangtelis - Tapòn - Embout - Abdeckkappe			
Kodas	Medž.	g	Sp.
084.206.003	PA	7	A
084.206.003G	PA	7	B

43x43 LAIKIKLIS

ANGOLARE 43X43
ESCUADRA 43X43
EQUERRE 43X43
ALUWINKEL 43X43

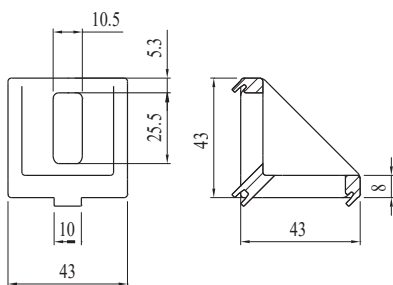

Kodas	Pastaba	g
084.305.026	Assembly with M8x20 screws, not included - Tvirtinimas M8x20 varžtais, nepridedami - Montage con tornillos M8x20, no incluidos - Montage avec vis M8x20 non fournies - Montage mit Schrauben M8x20 nicht im Lieferumfang enthalten	56

Sandblasted aluminium
Smėliapūte apdorotas aluminis
Aluminio arenado
Aluminium sablé
Sandgestrahltes Aluminium

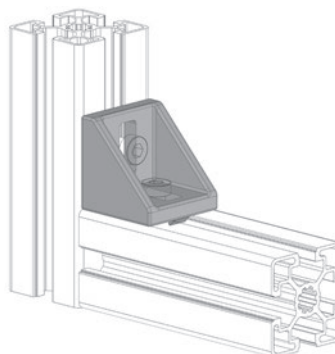

Cap - Dangtelis - Tapòn - Embout - Abdeckkappe			
Kodas	Medž.	g	Sp.
084.206.003	PA	7	A
084.206.003GM	PA	7	B



43x43 LAIKIKLIS

ANGOLARE 43X43
 ESCUADRA 43X43
 EQUERRE 43X43
 ALUWINKEL 43X43

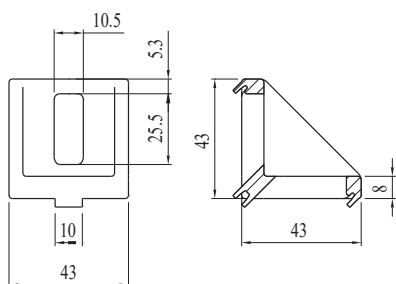

Kodas	Pastaba	g
084.305.026T	Assembly with M8x20 screws, not included - Tvirtinimas M8x20 varžtais, nepridedami - Montage con tornillos M8x20, no incluidos - Montage avec vis M8x20 non fournies - Montage mit Schrauben M8x20 nicht im Lieferumfang enthalten	56

Sandblasted aluminium
 Smėliapūte apdorotas aliuminis
 Aluminio arenado
 Aluminium sablé
 Sandgestrahltes Aluminium

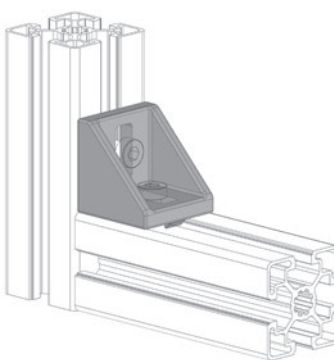

Cap - Dangtelis - Tapòn - Embout - Abdeckkappe			
Kodas	Medž.	g	Sp.
084.206.003	PA	7	A
084.206.003G	PA	7	B

43x43 LAIKIKLIS

ANGOLARE 43X43
 ESCUADRA 43X43
 EQUERRE 43X43
 ALUWINKEL 43X43

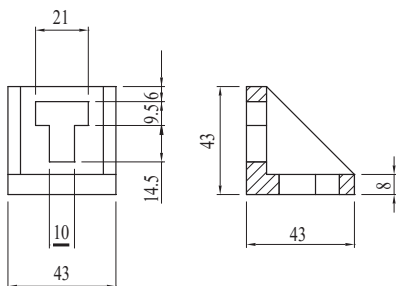
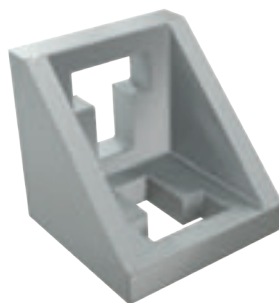

Kodas	Pastaba	g
084.305.021	Assembly with M8x20 screws, not included - Tvirtinimas M8x20 varžtais, nepridedamie - Montage con tornillos M8x20, no incluidos - Montage avec vis M8x20 non fournies - Montage mit Schrauben M8x20 (nicht im Lieferumfang enthalten)	60

Sandblasted aluminium
 Smėliapūte apdorotas aliuminis
 Aluminio arenado
 Aluminium sablé
 Sandgestrahltes Aluminium

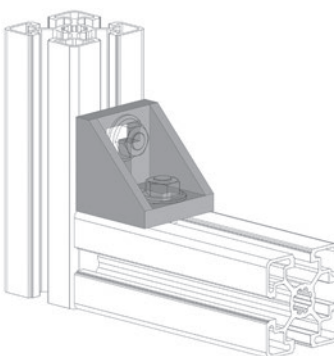



42x42 LAIKIKLIS

ANGOLARE 42X42
ESCUADRA 42X42
EQUERRE 42X42
ALUWINKEL 42X42

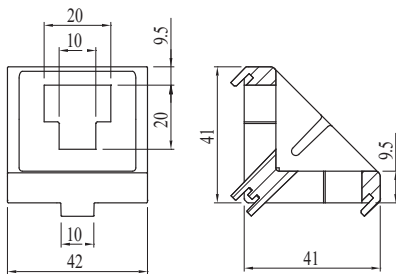

Kodas	Pastaba	g
084.305.045	Assembly with M8x20 screws, not included -Tvirtinimas M8x20 varžtais, nepridedami - Montaje con tornillos M8x20, no incluidos - Montage avec vis M8x20 non fournies - Montage mit Schrauben M8x20 (nicht im Lieferumfang enthalten)	54

Sandblasted aluminium
Smėliapūte apdorotas aluminis
Aluminio arenado
Aluminium sablé
Sandgestrahltes Aluminium

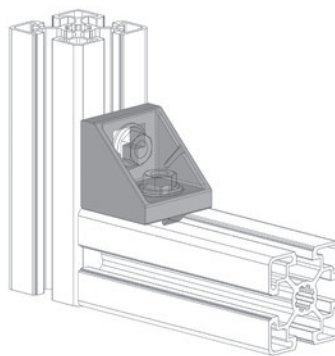

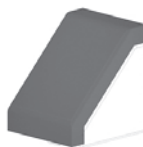
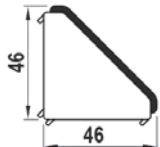
Cap - Dangtelis - Tapòn - Embout - Abdeckkappe			
			
Kodas	Medž.	g	Sp.
084.206.011	PA	8,6	A

42x42 LAIKIKLIS

ANGOLARE 42X42
ESCUADRA 42X42
EQUERRE 42X42
ALUWINKEL 42X42

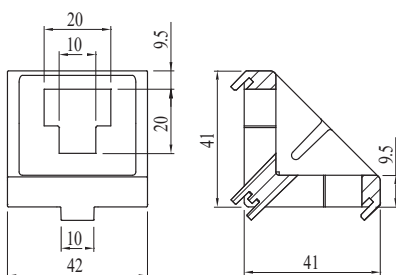

Kodas	Pastaba	g
084.305.045T	Assembly with M8x20 screws, not included - Tvirtinimas M8x20 varžtais, nepridedami - Montaje con tornillos M8x20, no incluidos - Montage avec vis M8x20 non fournies - Montage mit Schrauben M8x20 (nicht im Lieferumfang enthalten)	54

Tumbled aluminium
Alluminis vibracinis
Aluminio vibroacabado
Aluminium tribofini
Gleitgeschliffene Aluminium

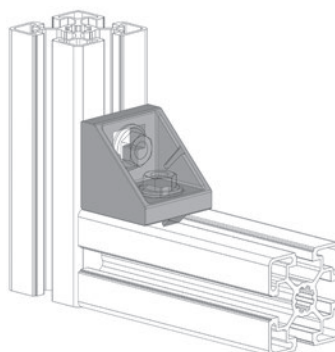

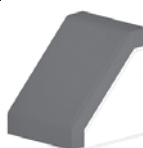
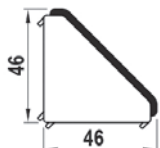
Cap - Dangtelis - Tapòn - Embout - Abdeckkappe			
			
Kodas	Medž.	g	Sp.
084.206.011	PA	8,6	A



43x86 LAIKIKLIS

ANGOLARE 43X86
ESCUADRA 43X86
EQUERRE 43X86
ALUWINKEL 43X86

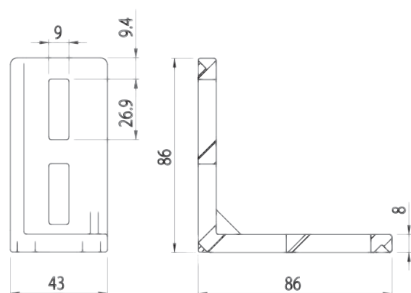

Sandblasted aluminium
Smėliapūte apdorotas aliuminis
Aluminio arenado
Aluminium sablé
Sandgestrahltes Aluminium

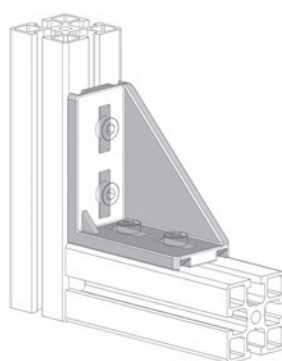

Cap - Dangtelis - Tapòn - Embout - Abdeckkappe			
Kodas	Medž.	g	Sp.
084.206.005	PA	34	A

43x86 LAIKIKLIS

ANGOLARE 43X86
ESCUADRA 43X86
EQUERRE 43X86
ALUWINKEL 43X86

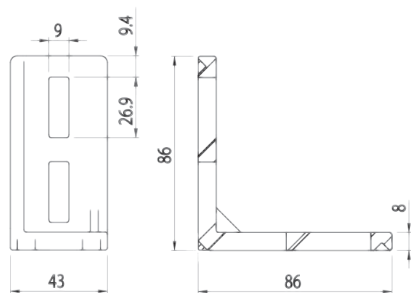

Tumbled aluminium
Alluminis vibracinis
Aluminio vibroacabado
Aluminium tribofini
Gleitgeschliffene Aluminium

Kodas	Pastaba	g
084.305.033	Assembly with M8x20 screws, not included - Tvirtinimas M8x20 varžtais, neprisidami - Montage con tornillos M8x20, no incluidos - Montage avec vis M8x20 non fournies - Montage mit Schrauben M8x20 (nicht im Lieferumfang enthalten)	54

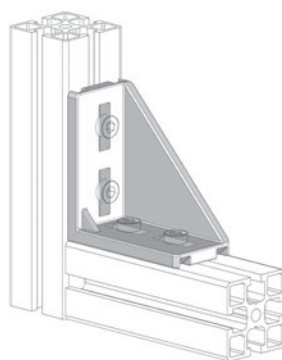

Cap - Dangtelis - Tapòn - Embout - Abdeckkappe			
Kodas	Medž.	g	Sp.
084.206.005	PA	34	A



43x86 LAIKIKLIS

ANGOLARE 43X86
 ESCUADRA 43X86
 EQUERRE 43X86
 ALUWINKEL 43X86



Kodas	Pastaba	g
084.305.028	Assembly with M8x20 screws, not included - Tvirtinimas M8x20 varžtais, nepridedami - Montaje con tornillos M8x20, no incluidos - Montage avec vis M8x20 non fournies - Montage mit Schrauben M8x20 nicht im Lieferumfang enthalten	162

Sandblasted aluminium
 Smėliapūte apdorotas aluminis
 Aluminio arenado
 Aluminium sablé
 Sandgestrahltes Aluminium

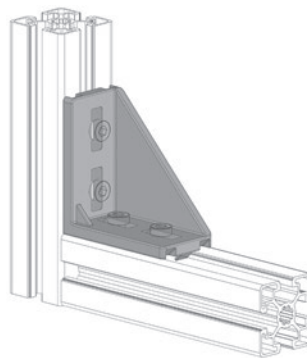
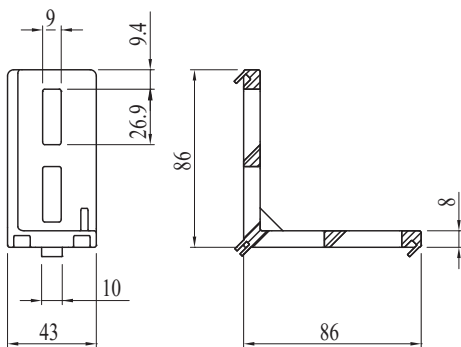

Cap - Dangtelis - Tapòn - Embout - Abdeckkappe			
Kodas	Medž.	g	Sp.
084.206.005	PA	34	A

43x86 LAIKIKLIS

ANGOLARE 43X86
 ESCUADRA 43X86
 EQUERRE 43X86
 ALUWINKEL 43X86



Kodas	Pastaba	g
084.305.028T	Assembly with M8x20 screws, not included - Tvirtinimas M8x20 varžtais, nepridedami - Montaje con tornillos M8x20, no incluidos - Montage avec vis M8x20 non fournies - Montage mit Schrauben M8x20 nicht im Lieferumfang enthalten	162

Tumbled aluminium
 Alluminis vibracinis
 Aluminio vibroacabado
 Aluminium tribofini
 Gleitgeschliffene Aluminium

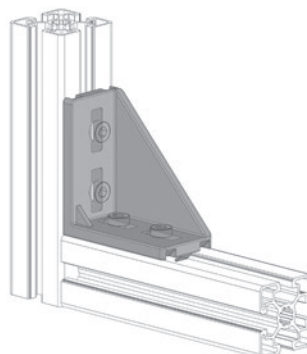
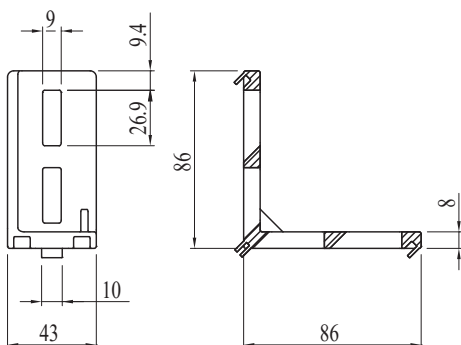

Cap - Dangtelis - Tapòn - Embout - Abdeckkappe			
Kodas	Medž.	g	Sp.
084.206.005	PA	34	A



86x86 LAIKIKLIS

ANGOLARE 86X86
ESCUADRA 86X86
EQUERRE 86X86
ALUWINKEL 86X86

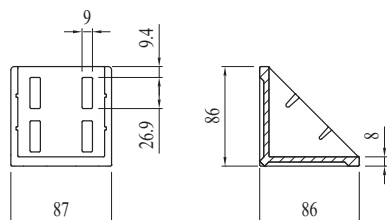

Kodas	Pastaba	g
084.305.034	Assembly with M8x20 screws, not included - Tvirtinimas M8x20 varžtais, nepridedami - Montaje con tornillos M8x20, no incluidos - Montage avec vis M8x20 non fournies - Montage mit Schrauben M8x20 (nicht im Lieferumfang enthalten)	350

Sandblasted aluminium
Smėliapūte apdorotas aliuminis
Aluminio arenado
Aluminium sablé
Sandgestrahltes Aluminium

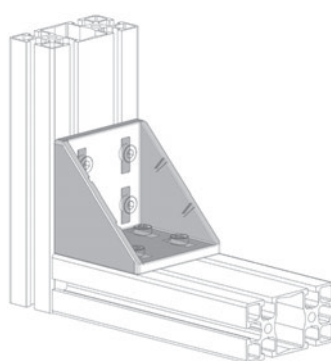

Cap - Dangtelis - Tapòn - Embout - Abdeckkappe			
Kodas	Medž.	g	Sp.
084.206.006	PA	30	A

86x86 LAIKIKLIS

ANGOLARE 86X86
ESCUADRA 86X86
EQUERRE 86X86
ALUWINKEL 86X86

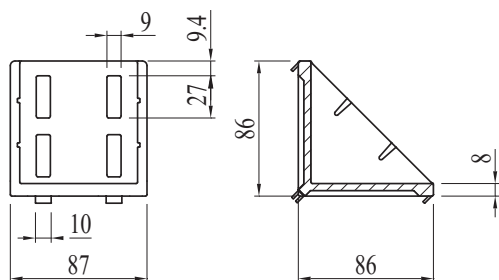

Kodas	Pastaba	g
084.305.030	Assembly with M8x20 screws, not included - Tvirtinimas M8x20 varžtais, nepridedami - Montaje con tornillos M8x20, no incluidos - Montage avec vis M8x20 non fournies - Montage mit Schrauben M8x20 nicht im Lieferumfang enthalten	334

Sandblasted aluminium
Smėliapūte apdorotas aliuminis
Aluminio arenado
Aluminium sablé
Sandgestrahltes Aluminium

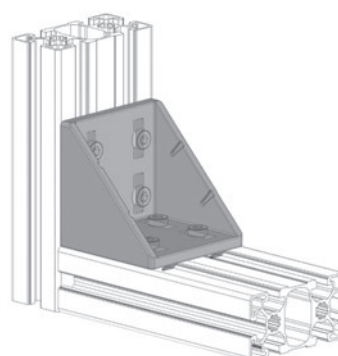

Cap - Dangtelis - Tapòn - Embout - Abdeckkappe			
Kodas	Medž.	g	Sp.
084.206.006	PA	30	A



**43x88 LAIKIKLIS**

ANGOLARE 43X88
 ESCUADRA 43X88
 EQUERRE 43X88
 ALUWINKEL 43X88

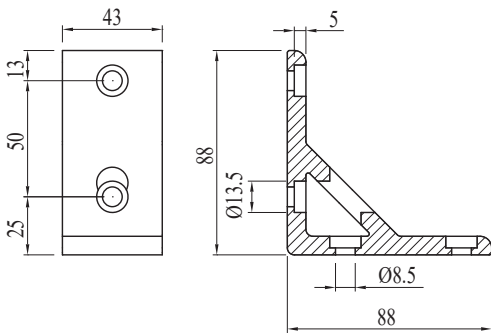

Kodas	Pastaba	g
084.305.042	Assembly with M8x16 screws, not included - Tvirtinimas M8x16 varžtais, nepridedami - Montaje con tornillos M8x16, no incluidos - Montage avec vis M8x16 non fournies - Montage mit Schrauben M8x16 nicht im Lieferumfang enthalten	22

Anodised aluminium
 Anodizuotas aliuminis
 Aluminium anodisé
 Eloxiertes Aluminium

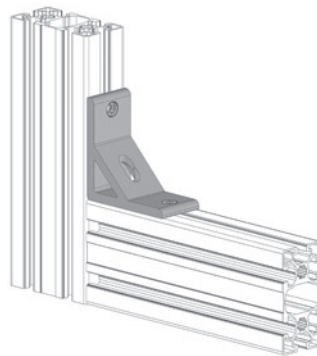
**88x88 LAIKIKLIS**

ANGOLARE 88X88
 ESCUADRA 88X88
 EQUERRE 88X88
 ALUWINKEL 88X88

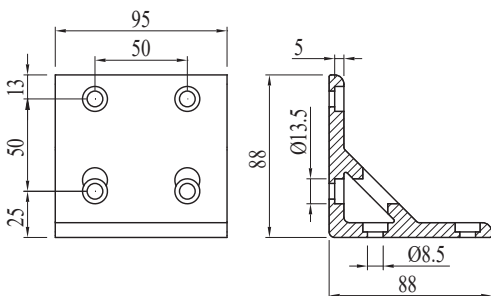

Kodas	Pastaba	g
084.305.043	Assembly with M8x16 screws, not included - Tvirtinimas M8x16 varžtais, nepridedami - Montaje con tornillos M8x16, no incluidos - Montage avec vis M8x16 non fournies - Montage mit Schrauben M8x16 nicht im Lieferumfang enthalten	44

Anodised aluminium
 Anodizuotas aliuminis
 Aluminium anodisé
 Eloxiertes Aluminium

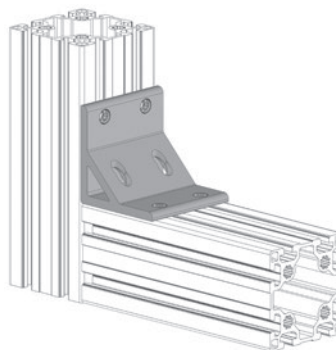



40x40 LAIKIKLIS

ANGOLARE 40X40
ESCUADRA 40X40
EQUERRE 40X40
ALUWINKEL 40X40

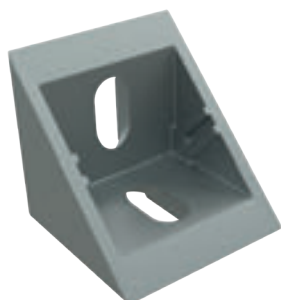

Kodas	Pastaba	g
084.305.047	Assembly with M8x16 screws, not included - Tvirtinimas M8x16 varžtais, nepridedami - Montage con tornillos M8x16, no incluidos - Montage avec vis M8x16 non fournies - Montage mit Schrauben M8x16 (nicht im Lieferumfang enthalten)	77

Grey painted RAL 9006 zamak
Zamak, dažytas pilkai RAL 9006
Zamak barnizado en gris RAL 9006
Zamak peint gris RAL 9006
Grau lackierte RAL-Farbe 9006 Zamak-Legierung

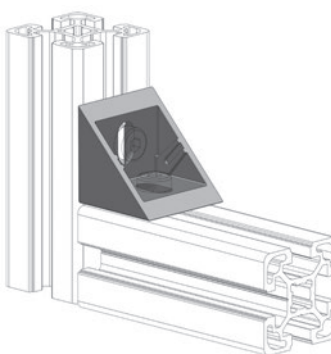
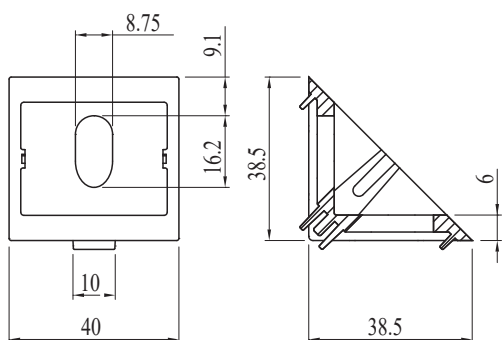

Cap - Dangtelis - Tapòn - Embout - Abdeckkappe			
Kodas	Medž.	g	Sp.
084.206.010	PA	8,6	A

40x40 LAIKIKLIS

ANGOLARE 40X40
ESCUADRA 40X40
EQUERRE 40X40
ALUWINKEL 40X40

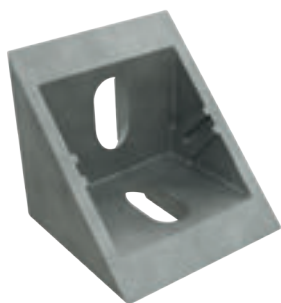

Kodas	Pastaba	g
084.305.047T	Assembly with M8x16 screws, not included - Tvirtinimas M8x16 varžtais, nepridedami - Montage con tornillos M8x16, no incluidos - Montage avec vis M8x16 non fournies - Montage mit Schrauben M8x16 (nicht im Lieferumfang enthalten)	77

Tumbled zamak
Zamak vibracinis lydinys
Zamak vibroacabado
Zamak tribofini
Gleitgeschliffene Zamak-Legierung

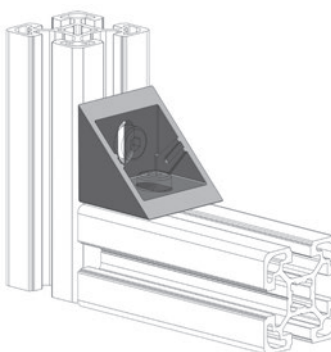
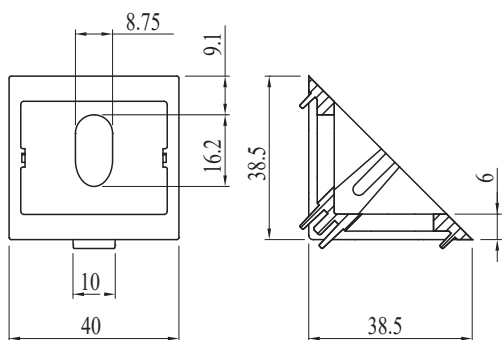

Cap - Dangtelis - Tapòn - Embout - Abdeckkappe			
Kodas	Medž.	g	Sp.
084.206.010	PA	8,6	A



40x80 LAIKIKLIS

ANGOLARE 40X80
 ESCUADRA 40X80
 EQUERRE 40X80
 ALUWINKEL 40X80

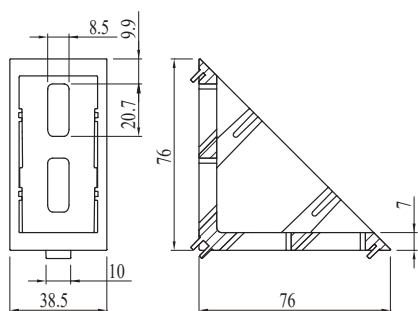

Kodas	Pastaba	g
084.305.049	Assembly with M8x16 screws, not included - Tvirtinimas M8x16 varžtais, nepridedami - Montage con tornillos M8x16, no incluidos - Montage avec vis M8x16 non fournies - Montage mit Schrauben M8x16 (nicht im Lieferumfang enthalten)	270

Grey painted RAL 9006 zamak
 Zamak pilkai dažytas RAL 9006
 Zamak barnizado en gris RAL 9006
 Zamak peint gris RAL 9006
 Grau lackierte RAL-Farbe 9006 Zamak-Legierung

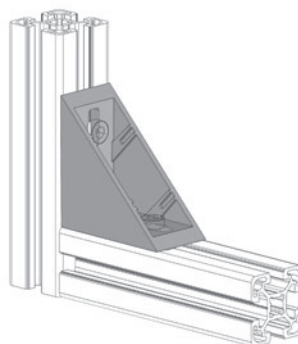

Cap - Dangtelis - Tapòn - Embout - Abdeckkappe			
		78	78
Kodas	Medž.	g	Sp.
084.206.012	PA	20	A

40x80 LAIKIKLIS

ANGOLARE 40X80
 ESCUADRA 40X80
 EQUERRE 40X80
 ALUWINKEL 40X80

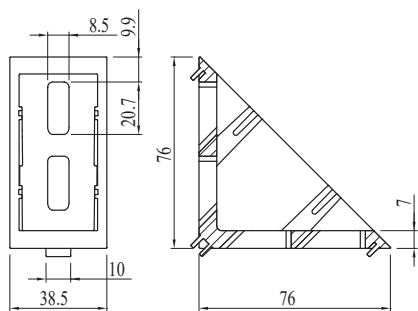

Kodas	Pastaba	g
084.305.049T	Assembly with M8x16 screws, not included - Tvirtinimas M8x16 varžtais, nepridedami - Montage con tornillos M8x16, no incluidos - Montage avec vis M8x16 non fournies - Montage mit Schrauben M8x16 (nicht im Lieferumfang enthalten)	270

Tumbled zamak
 Zamak vibracinis lydinys
 Zamak vibroacabado
 Zamak tribofini
 Gleitgeschliffene Zamak-Legierung

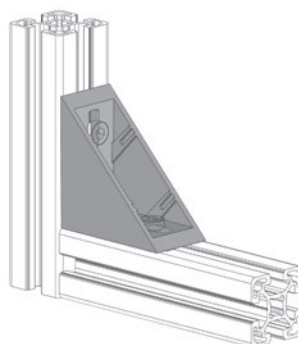

Cap - Dangtelis - Tapòn - Embout - Abdeckkappe			
		78	78
Kodas	Medž.	g	Sp.
084.206.012	PA	20	A



20x20 LAIKIKLIS

ANGOLARE 20X20
 ESCUADRA 20X20
 EQUERRE 20X20
 ALUWINKEL 20X20

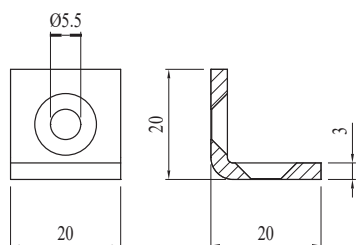

Kodas	Pastaba	g
084.305.037	Assembly with M5 screws, not included - Tvirtinimas M5 Varžtais, nepridedami - Montaje con tornillos M5, no incluidos - Montage avec vis M5 non fournies - Montage mit Schrauben M5 (nicht im Lieferumfang enthalten)	13

Black painted steel
 Juodai dažytas plienas
 Acero barnizado en negro
 Acier peint noir
 Stahl schwarz lackiert

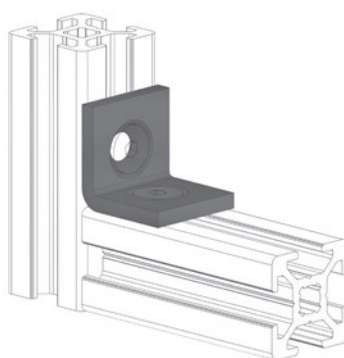

30x30 LAIKIKLIS

ANGOLARE 30X30
 ESCUADRA 30X30
 EQUERRE 30X30
 ALUWINKEL 30X30

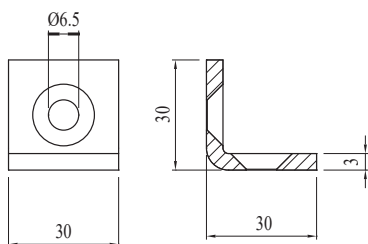

Kodas	Pastaba	g
084.305.038	Assembly with M6 screws, not included - Tvirtinimas M6 Varžtais, nepridedami - Montaje con tornillos M6, no incluidos - Montage avec vis M6 non fournies - Montage mit Schrauben M6 (nicht im Lieferumfang enthalten)	41

Black painted steel
 Juodai dažytas plienas Acero
 barnizado en negro Acier
 peint noir
 Stahl schwarz lackiert

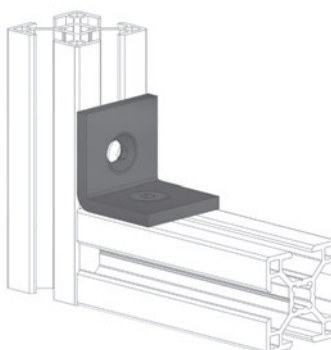

**40x40 LAIKIKLIS**

ANGOLARE 40X40
 ESCUADRA 40X40
 EQUERRE 40X40
 ALUWINKEL 40X40

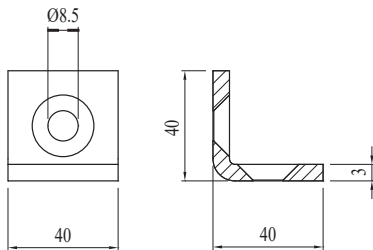

Kodas	Pastaba	g
084.305.039	Assembly with M8 screws, not included - Tvirtinimas M8 Varžtais, nepridedami - Montaje con tornillos M8, no incluidos - Montage avec vis M8 non fournies - Montage mit Schrauben M8 (nicht im Lieferumfang enthalten)	80

Black painted steel
 Juodai dažytas plienas
 Acero barnizado en negro
 Acier peint noir
 Stahl schwarz lackiert

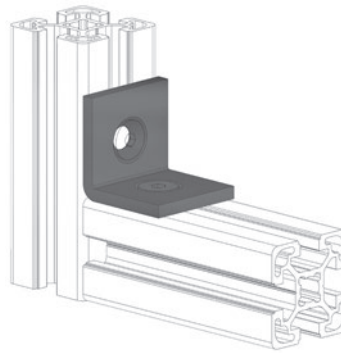
**30X30 LAIKIKLIS**

ANGOLARE 30X30
 ESCUADRA 30X30
 EQUERRE 30X30
 ALUWINKEL 30X30

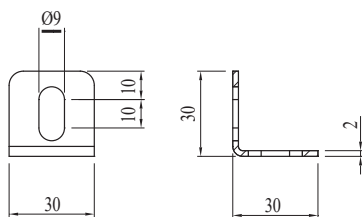

STAINLESS STEEL

Kodas	Pastaba	g
084.305.016	Assembly with M8x16 screws, not included - Surinkimas su M8x16 varžtais - Montaje con tornillos M8x16, no incluidos - Montage avec vis M8x16 non fournies - Montage mit Schrauben M8x16 (nicht im Lieferumfang enthalten)	23

Stainless steel
 Nerūdijantis plienas
 Acero inoxidable
 Acier inox Rostfreier
 Stahl

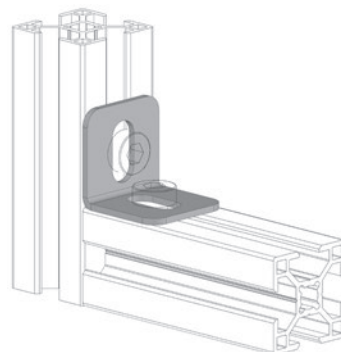



30x30 LAIKIKLIS

ANGOLARE 30X30
 ESCUADRA 30X30
 EQUERRE 30X30
 ALUWINKEL 30X30

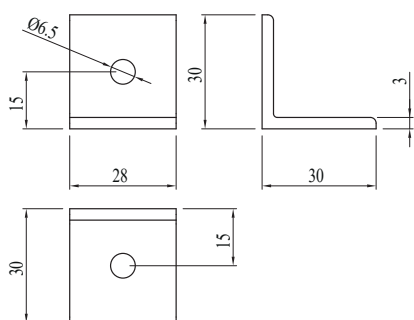

NEW

Kodas	Pastaba	g
084.305.017	Assembly with M6 screws, not included - Tvirtinimas M6 Varžtais, nepridedami - Montaje con tornillos M6, no incluidos - Montage avec vis M6 non fournies - Montage mit Schrauben M6 (nicht im Lieferumfang enthalten)	12

Tumbled aluminium
 Alluminio vibraciniu būdu apdorotas
 Aluminio vibroacabado
 Aluminium tribofini Gleitgeschliffene
 Aluminium

40x40 LAIKIKLIS

ANGOLARE 40X40
 ESCUADRA 40X40
 EQUERRE 40X40
 ALUWINKEL 40X40

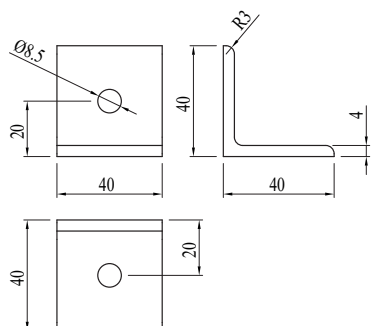

Kodas	Pastaba	g
084.305.056	Assembly with M5 screws, not included - Tvirtinimas M5 Varžtais, nepridedami - Montaje con tornillos M5, no incluidos - Montage avec vis M5 non fournies - Montage mit Schrauben M5 (nicht im Lieferumfang enthalten)	30

Steel
 Plienas
 Acero
 Acier
 Stahl



PLATE FOR FEET AND WHEELS

PIASTRA PER PIEDI E RUOTE PLETINA
 PARA PIES Y RUEDAS
 PLAQUE POUR PIEDES ET ROUES
 PLATTE FÜR FÜSSE UND RÄDER

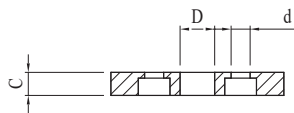
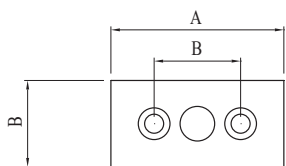

Kodas	Pastaba	d	A	D	B	s	g
084.405.023		8,5	60	M12	30	8	32
084.405.027		8,5	80	M12	40	12	80
084.405.005		8,5	80	M16	40	12	80
084.405.010		8,5	90	M10	45	12	85
084.405.013		8,5	90	M12	45	12	84
084.405.001		8,5	90	M16	45	12	83
084.405.011		8,5	90	M20	45	12	80
084.405.004		8,5	90	1/4"	45	12	120
084.405.007		8,5	90	3/8"	45	12	114
084.405.015		8,5	90	1/2"	45	12	110
084.405.016		8,5	90	-	45	10	100
084.405.017		13	100	M10	50	12	133
084.405.018		13	100	M12	50	12	130
084.405.019		13	100	M16	50	12	125
084.405.020		13	100	M20	50	12	120

Aluminium
 Alluminis
 Aluminio
 Aluminium
 Aluminium





TARPIKLIS 45x90
GUARNIZIONE JUNTA
JOINT DICHTUNG

Kodas	Pastaba	g
084.536.001	Seal for 45x90 - Guarnizione di tenuta per 45x90 - Junta de estanqueidad para 45x90 - Joint d'étanchéité pour 45x90 - Dichtung für 45x90	12



EPDM

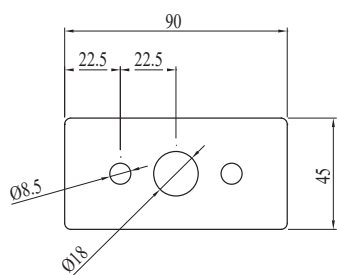



PLOKŠTĖ KOJŲ IR RATUKŲ TVIRTINIMUI

PIASTRA PER PIEDI E RUOTE PLETINA PARA PIES Y
RUEDAS PLAQUE POUR PIEDES ET ROUES PLATTE
FÜR FÜSSE UND RÄDER



Kodas	Pastaba	d	A	D	B	s	g
084.405.024		8,50	60	M12	30	10	85
084.405.006		6,50	80	M16	40	15	234
084.405.025		13	90	M16	45	15	220
084.405.026		13	90	M20	45	15	220
084.405.021		13	100	M16	50	15	420
084.405.022		13	100	M20	50	15	400

Anodised aluminium
Anodizuotas aliuminis
Aluminium anodisé
Eloxiertes Aluminium

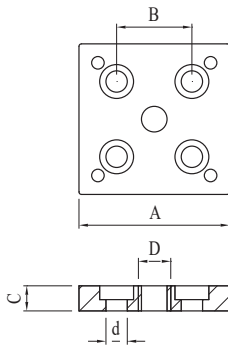



KAMPINIS LAIKIKLIS
RINFORZO ANGOLARE
REFUERZO ANGULAR RENFORT
D'ANGLE WINKELFÖRMIGE
VERSTÄRKUNG

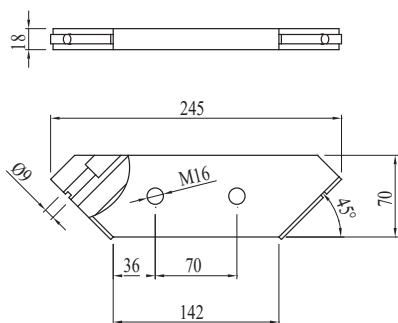

Kodas	Pastaba	g
084.406.001	To fasten to the structure with two M8x40 screws - Tvirtinimas prie konstrukcijos dviem M8x40 varžtais - Sefija a la estructura con dos tornillos M8x40 - À fixer à la structure avec deux vis M8x40 - Mit zwei Schrauben M8x40 an der Struktur zu befestigen	720

Anodised aluminium
Anodizuotas aliuminis
Aluminium anodisé
Eloxiertes Aluminium



**40x40 TRIKOJIS KOJOMS**BH
10
40

TRÍPIEDE 40X40 TRÍPODE 40X40 TRÉPIED
40X40 DREIFUSS 40X40



Kodas	Pastaba	g
084.408.003	Suitable for M16 articulated feet - Adapteris prie M16 stumdomų ratų- Apto para pies articulados M16 - Adapté aux pieds articulés M16 - Geeignet für Gelenkfüße M16	1010

Black polyamide
Juodas poliamidas
Poliamida color negro
Polyamide noir Polyamid
schwarz

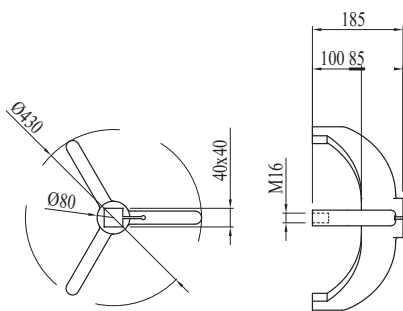
**45x45 TRIKOJIS KOJOMS**SHARED COMPONENT
AC / BHBH L
10
45
BH H
10
45

TRÍPIEDE 45X45 TRÍPODE 45X45 TRÉPIED
45X45 DREIFUSS 45X45



Kodas	Pastaba	g
084.408.001	Suitable for M16 articulated feet - Adapteris prie M16 stumdomų ratų - Apto para pies articulados M16 - Adapté aux pieds articulés M16 - Geeignet für Gelenkfüße M16	984

Black polyamide
Juodas poliamidas
Poliamida color negro
Polyamide noir
Polyamid schwarz

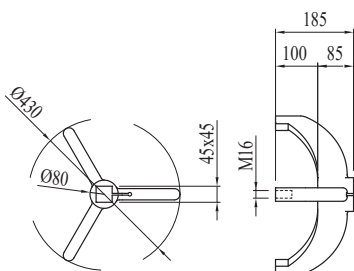



GRINDINIS LAIKIKLIS 30x160



STAFFA A PAVIMENTO
ESCUADRA PARA FIJACIÓN EN SUELO
EQUERRE D'ANCRAGE BODENWINKEL

Kodas	Pastaba	g
084.409.006	For 30 mm profiles - Profiliui 30 mm - Para perfiles de 30 mm - Pour profilés 30 mm - Für Profile 30 mm	173



Grey painted steel
Plienas pilkai dažytas
Acero barnizado en gris
Acier peint gris
Stahl grau lackiert

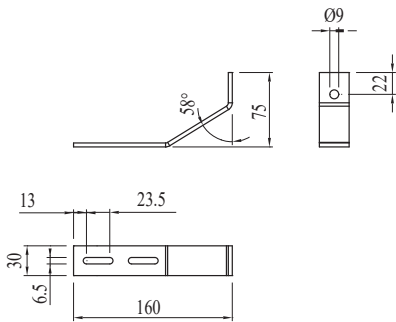

GRINDINIS LAIKIKLIS 40x160



STAFFA A PAVIMENTO
ESCUADRA PARA FIJACIÓN EN SUELO
EQUERRE D'ANCRAGE BODENWINKEL

Kodas	Pastaba	g
084.409.007	For 40 mm profiles - Profiliui 40 mm - Para perfiles de 40 mm - Pour profilés 40 mm - Für Profile 40 mm	242



Grey painted steel
Plienas pilkai dažytas
Acero barnizado en gris
Acier peint gris
Stahl grau lackiert

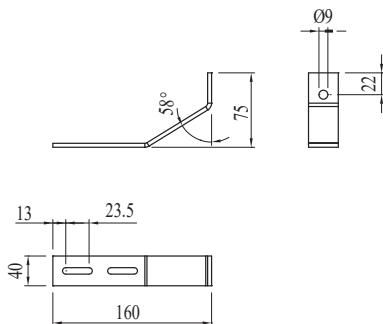

**GRINDINIS LAIKIKLIS 20x160x60**

STAFFA A PAVIMENTO
 ESCUADRA PARA FIJACIÓN EN SUELO EQUERRE
 D'ANCRAGE BODENWINKEL

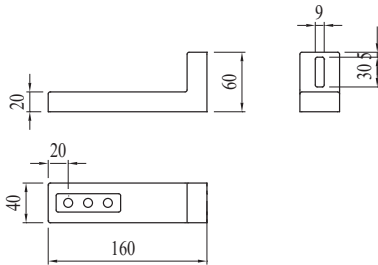

Kodas	Pastaba	g
084.409.008	For 40 mm profiles - Profiliui 40 mm - Para perfiles de 40 mm - Pour profilés 40 mm - Für Profile 40 mm	208

Black painted Zamak
 Zamak dažytas juodai
 Zamak barnizado en negro
 Zamak peint noir
 Zamak schwarz lackiert

**GRINDINIS LAIKIKLIS 30x200**

STAFFA A PAVIMENTO
 ESCUADRA PARA FIJACIÓN EN SUELO
 EQUERRE D'ANCRAGE BODENWINKEL

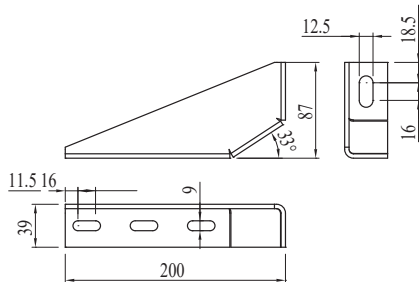

Kodas	Pastaba	g
084.409.015	For 40 mm profiles - Profiliui 40 mm - Para perfiles de 40 mm - Pour profilés 40 mm - Für Profile 40 mm	520

Galvanised steel
 Cinkuotas plienas
 Acero galvanizado
 Acier zingué
 Verzinkter Stahl





GRINDINIS LAIKIKLIS 45x160x75



STAFFA A PAVIMENTO
ESCUADRA PARA FIJACIÓN
EN SUELO EQUERRE D'ANCRAGE BODENWINKEL

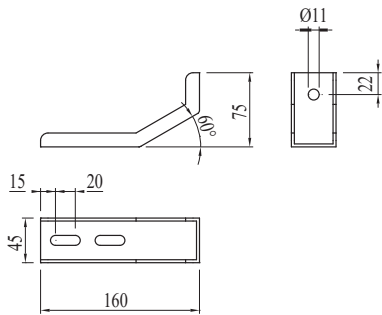

Kodas	Pastaba	g
084.409.001	Profiluiui 45 mm - For 45 mm profiles - Para perfiles de 45 mm - Pour profilés 45 mm - Für Profile 45 mm	303

Grey painted steel
Plienas pilkai dažytas
Acero barnizado en gris
Acier peint gris
Stahl grau lackiert



GRINDINIS LAIKIKLIS 45x200x80



STAFFA A PAVIMENTO
ESCUADRA PARA FIJACIÓN EN SUELO EQUERRE
D'ANCRAGE BODENWINKEL

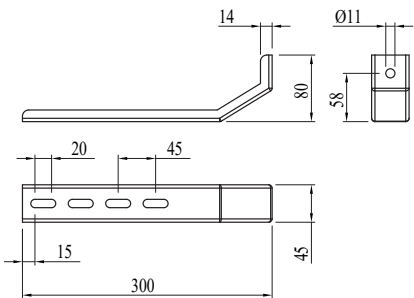

Kodas	Pastaba	g
084.409.016	For 45 mm profiles - Per profili 45 mm - Para perfiles de 45 mm - Pour profilés 45 mm - Für Profile 45 mm	303

Grey painted steel
Plienas pilkai dažytas
Acero barnizado en gris
Acier peint gris
Stahl grau lackiert





IŠLYGINIMO PĖDELĖ

PIEDE FISSO
 PIE FIJO
 PIED FIXE
 FESTER STELLFUSS



Kodas	Pastaba	g
084.408.002	For 45 mm profiles - Profiliams 40 ir 45 mm - Para perfiles de 45 mm - Pour profilés 45 mm - Für Profile 45 mm	130

Aluminium, EPDM, stainless steel
 Aliuminis, EPDM, nerūdijantis plienas
 Aluminio, EPDM, acero inoxidable
 Aluminium, EPDM, acier inox
 Aluminium, EPDM, rostfreier Stahl

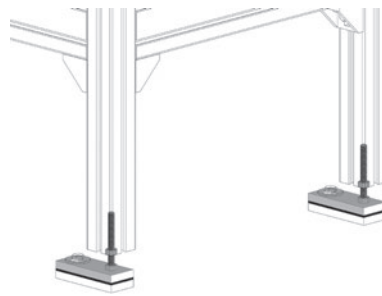
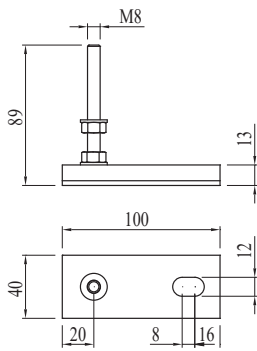

**NESPLYSTANČIOS IŠLYGINANČIOS, PASUKAMOS KOJELĖS**

PIEDI SNODATI ANTIVIBRANTI
 PIES ARTICULADOS ANTIVIBRACIÓN PIEDS ARTICULÉS ANTI-
 VIBRATION GELENKSTELLFÜSSE MIT ANTI-SLIP PLATTE

Kodas	WKg	D	d	A	B	C	E	F	Ch	g
084.401.004	450	40	M6	65	18	47	-	-	-	26
084.401.001	900	40	M8	68	23	45	-	-	6	29
084.401.002	900	50	M8	88	23	65	-	-	6	39
084.401.003	900	50	M10	95	25	70	-	-	8	55



Black polyamide
 Juodas poliamidas
 Poliamida color negro
 Polyamide noir Polyamid
 schwarz

Galvanized steel
 Cinkuotas plienas
 Acero galvanizado
 Acier zingué
 Verzinkter Stahl

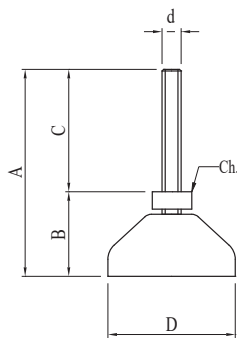



NESPLYSTANČIOS IŠLYGINANČIOS, PASUKAMOS KOJELĖS
 PIEDI SNODATI ANTIVIBRANTI
 PIES ARTICULADOS ANTIVIBRACIÓN PIEDS ARTICULÉS ANTI-VIBRATION
 GELENKSTELLFÜSSE MIT ANTI-SLIP PLATTE

Kodas	W Kg	D	d	A	B	C	E	F	Ch	g
084.402.001	1000	80	M8	74	29	45	54	9	6	53
084.402.002	1000	80	M10	101	31	70	54	9	8	75
084.402.003	1000	80	M12	96	33	63	54	9	10	88
084.402.004	1000	80	M16	97	37	60	54	9	13	141
084.402.008	1000	100	M16	165	40	125	74	9	13	240
084.402.005	2200	100	M16	195	40	155	74	10,5	13	293
084.402.006	2200	100	M20	130	44	86	74	10,5	17	303

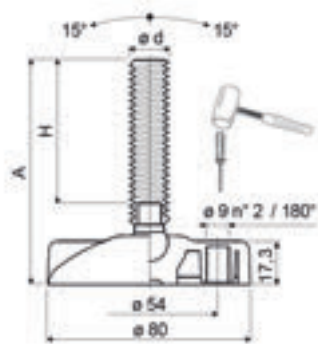

Black polyamide
 Juodas poliamidas
 Poliamida color negro
 Polyamide noir
 Polyamid schwarz

Galvanized steel
 Cinkuotas plienas
 Acero galvanizado
 Acier zingué
 Verzinkter Stahl





PADUKAS NUO SLYDIMO
ANTIVIBRANTI
PLACAS ANTIDESLIZANTES
PASTILLES ANTIVIBRATION ANTISLIP
PLATTEN



Kodas	Pastaba	g
084.403.001	Ø 40	6
084.403.002	Ø 50	12
084.403.003	Ø 80	36
084.403.004	Ø 100	63

Black oil-resistant synthetic rubber
Juoda, aliejui atspari sintetinė guma
Goma sintética antiaceite color negro
Caoutchouc synthétique anti-huile noir
Ölbeständiger Synthesekautschuk schwarz



MONTAVIMO PRIE GRINDŲ PAGRINDAS

BASE A PAVIMENTO
BASE DE ANCLAJE
EMBASE DE FIXATION PFOSTENKONSOLE

Kodas	Pastaba	g
084.410.006	80x80 mm	2360



Grey painted steel
Plienas pilkai dažytas
Acero barnizado en gris
Acier peint gris
Stahl grau lackiert

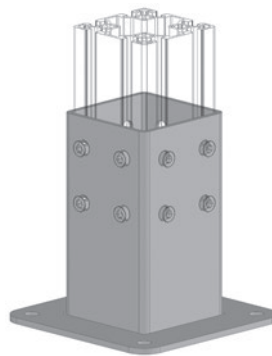
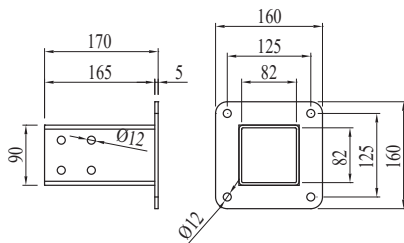

MONTAVIMO PRIE GRINDŲ PAGRINDAS

BASE A PAVIMENTO
BASE DE ANCLAJE
EMBASE DE FIXATION PFOSTENKONSOLE

Kodas	Pastaba	g
084.410.003	90x90 mm	2364



Grey painted steel
Plienas pilkai dažytas
Acero barnizado en gris
Acier peint gris
Stahl grau lackiert

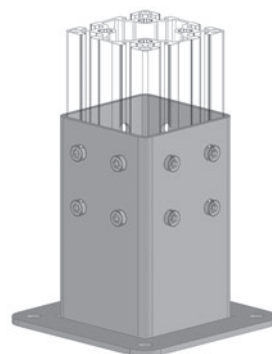
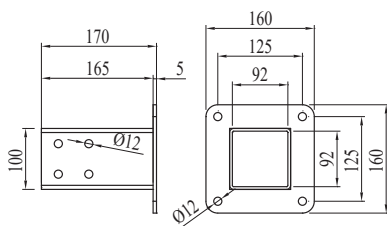



MONTAVIMO PRIE GRINDŲ PAGRINDAS



BASE A PAVIMENTO
BASE DE ANCLAJE
EMBASE DE FIXATION
PPOSTENKONSOLE

Kodas	Pastaba	g
084.409.004	40x40 mm	661

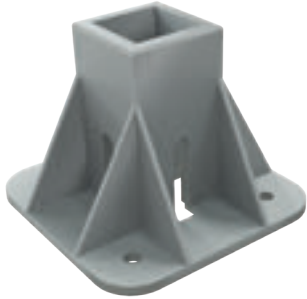

Sandblasted aluminium
Smėliapūte apdorotas aliuminis
Aluminio arenado
Aluminium sablé
Sandgestrahltes Aluminium

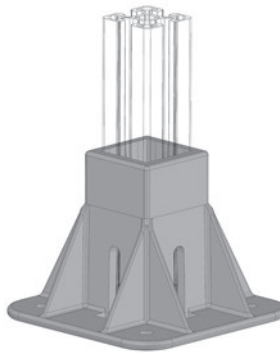
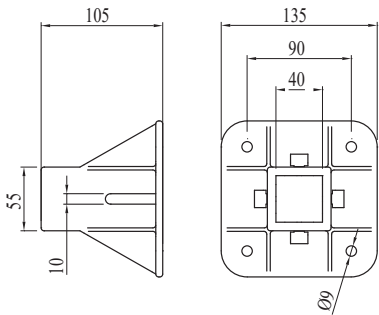

Cap - Dangtelis - Tapòn - Embout - Abdeckkappe			
Kodas	Medž.	g	Sp.
084.207.003	PA	100	B

MONTAVIMO PRIE GRINDŲ PAGRINDAS



BASE A PAVIMENTO
BASE DE ANCLAJE
EMBASE DE FIXATION
PPOSTENKONSOLE

Kodas	Pastaba	g
084.409.005	40x80 mm, 40x120 mm	800



Sandblasted aluminium
Smėliapūte apdorotas aliuminis
Aluminio arenado
Aluminium sablé
Sandgestrahltes Aluminium

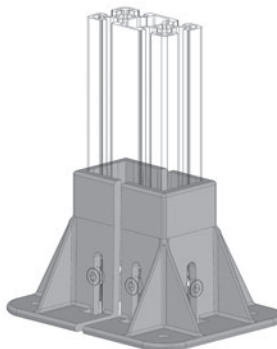
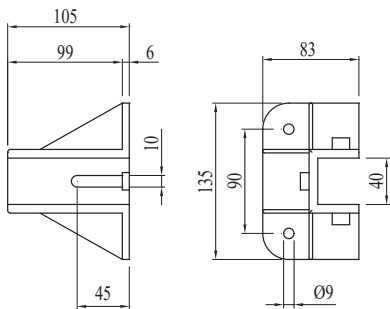

Cap - Dangtelis - Tapòn - Embout - Abdeckkappe			
Kodas	Medž.	g	Sp.
084.207.003	PA	100	B



MONTAVIMO PRIE GRINDŲ PAGRINDAS 100x100x170

NEW

Kodas	Pastaba	g
084.409.018	60x60 mm	1080



Sandblasted aluminium
Smėliapūte apdorotas aliuminis
Aluminio arenado
Aluminium sablé
Sandgestrahltes Aluminium

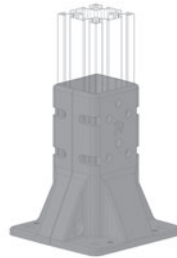
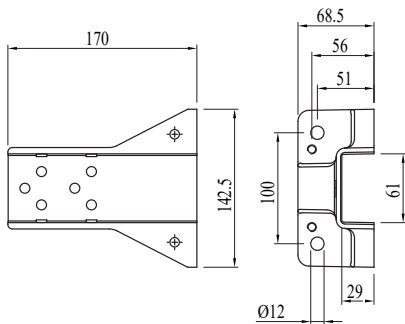

MONTAVIMO PRIE GRINDŲ PAGRINDAS 160x160x170

BASE A PAVIMENTO
BASE DE ANCLAJE
EMBASE DE FIXATION
PFOSTENKONSOLE



Kodas	Pastaba	g
084.409.014	80x80, 80x120, 80x160 mm	1400



Sandblasted aluminium
Smėliapūte apdorotas aliuminis
Aluminio arenado
Aluminium sablé
Sandgestrahltes Aluminium

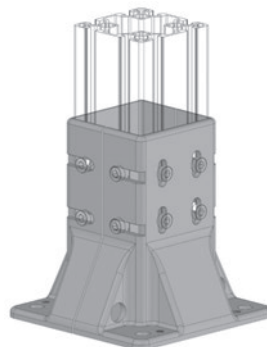
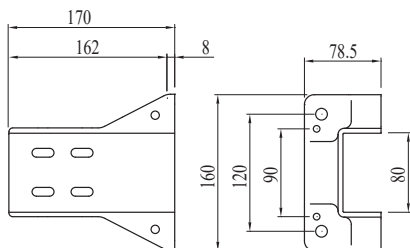



MONTAVIMO PRIE GRINDŲ PAGRINDAS 135x135x105



BASE A PAVIMENTO
BASE DE ANCLAJE
EMBASE DE FIXATION
PFOSTENKONSOLE

Kodas	Pastaba	g
084.409.002	45x45 mm	562

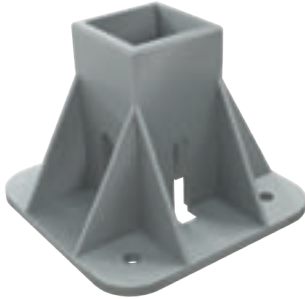

Sandblasted aluminium
Smėliapūte apdorotas aliuminis
Aluminio arenado
Aluminium sablé
Sandgestrahltes Aluminium

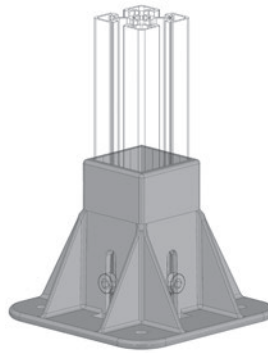
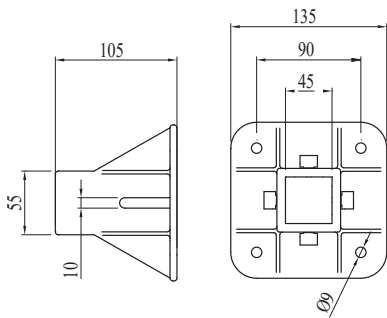

Cap - Dangtelis - Tapòn - Embout - Abdeckkappe			
Kodas	Medž.	g	Sp.
084.207.003	PA	100	B

MONTAVIMO PRIE GRINDŲ PAGRINDAS 135x135x105



BASE A PAVIMENTO
BASE DE ANCLAJE
EMBASE DE FIXATION
PFOSTENKONSOLE

Kodas	Pastaba	g
084.409.003	45x90 mm, 45x135 mm, 45x180 mm	672



Sandblasted aluminium
Smėliapūte apdorotas aliuminis
Aluminio arenado
Aluminium sablé
Sandgestrahltes Aluminium

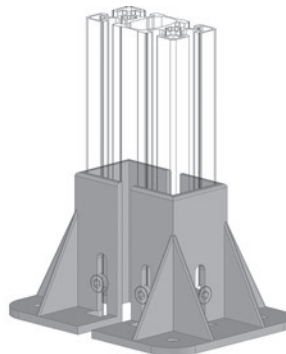
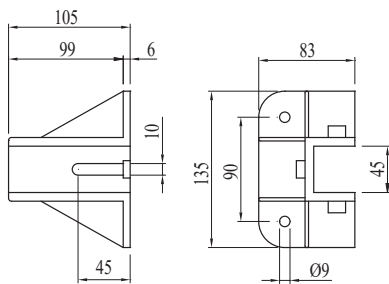



MONTAVIMO PRIE GRINDŲ PAGRINDAS 170x170x170

BASE A PAVIMENTO
 BASE DE ANCLAJE
 EMBASE DE FIXATION
 PFOSTENKONSOLE



Kodas	Pastaba	g
084.409.011	90x90 mm, 90x180 mm	2300



Sandblasted aluminium
 Smėliapūte apdorotas aliuminis
 Aluminio arenado
 Aluminium sablé
 Sandgestrahltes Aluminium

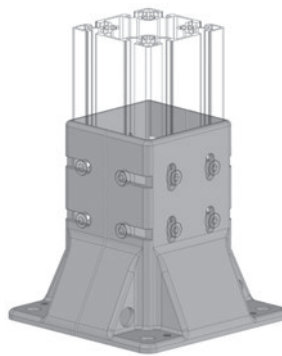
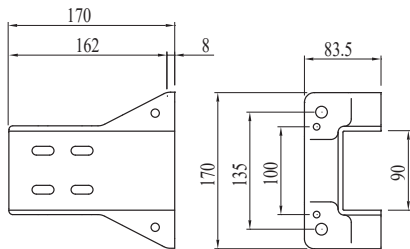

MONTAVIMO PRIE GRINDŲ PAGRINDAS 135x92x105

BASE A PAVIMENTO
 BASE DE ANCLAJE
 EMBASE DE FIXATION
 PFOSTENKONSOLE



Kodas	Pastaba	g
084.409.013	50x50 mm	344



Sandblasted aluminium
 Smėliapūte apdorotas aliuminis
 Aluminio arenado
 Aluminium sablé
 Sandgestrahltes Aluminium

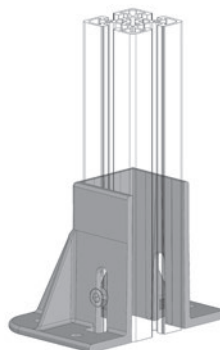
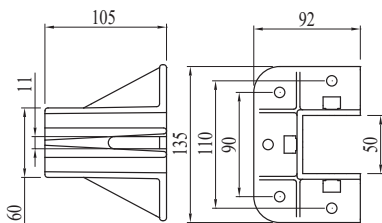



MONTAVIMO PRIE GRINDŲ PAGRINDAS 135x135x105



BASE A PAVIMENTO
BASE DE ANCLAJE
EMBASE DE FIXATION
PFOSTENKONSOLE

Kodas	Pastaba	g
084.409.009	50x50 mm	580

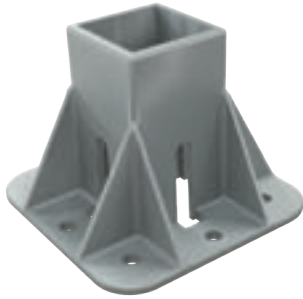

Sandblasted aluminium
Smėliapūte apdorotas aliuminis
Aluminio arenado
Aluminium sablé
Sandgestrahltes Aluminium

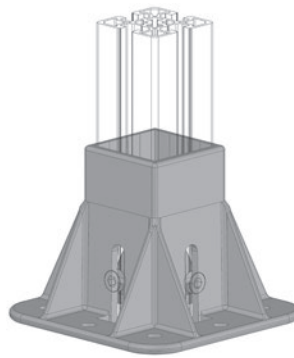
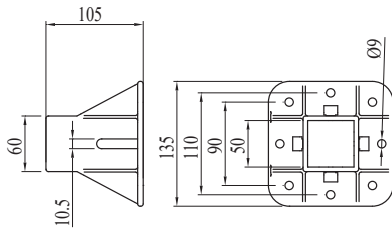

MONTAVIMO PRIE GRINDŲ PAGRINDAS 135x92x105



BASE A PAVIMENTO
BASE DE ANCLAJE
EMBASE DE FIXATION
PFOSTENKONSOLE

Kodas	Pastaba	g
084.409.010	50x100 mm	688



Sandblasted aluminium
Smėliapūte apdorotas aliuminis
Aluminio arenado
Aluminium sablé
Sandgestrahltes Aluminium

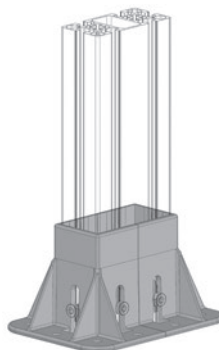
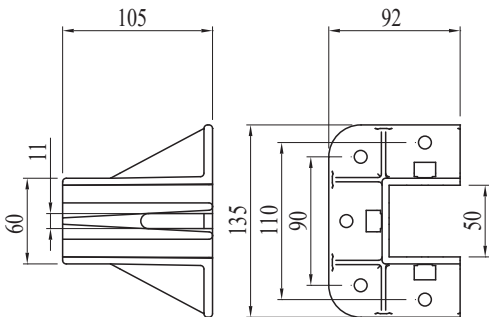



MONTAVIMO PRIE GRINDŲ PAGRINDAS 170x170x170



BASE A PAVIMENTO
 BASE DE ANCLAJE
 EMBASE DE FIXATION
 PFOSTENKONSOLE

Kodas	Pastaba	g
084.409.012	100x100 mm	1500



Sandblasted aluminium
 Smėliapūte apdorotas aliuminis
 Aluminio arenado
 Aluminium sablé
 Sandgestrahltes Aluminium

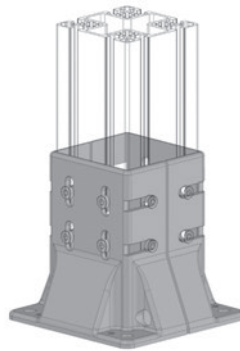
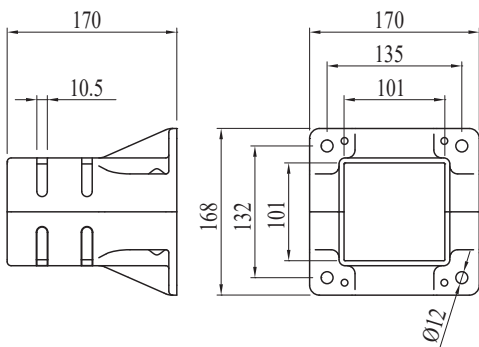

STULPO DANGTELIS, 45x45

TAPPO PER PIANTONE 45X45
 TAPÓN PARA COLUMNA 45X45
 CHAPEAU POUR COLONNE 45X45
 ABDECKKAPPE FÜR PFOSTEN 45X45

Kodas	Pastaba	g
084.207.004	For 45x45 mm square profiles - Profiliams 45x45 mm quadrati - Para perfiles de 45x45 mm cuadrados - Pour profilés 45x45 carrés - Für Profile 45x45 mm viereckig	20



Pilkas poliamidas
 Poliamidas pilkas
 Poliamida color gris
 Polyamide gris
 Polyamid grau

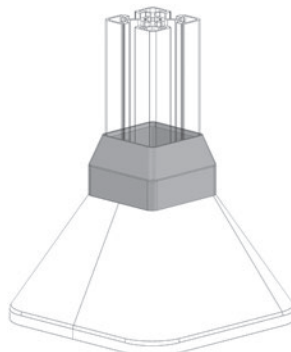
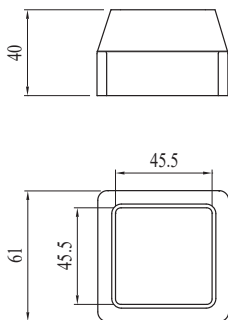

**2 DALIŲ TELESKOPINĖ KĖLIMO KOLONA****135.070.400.2**

H max: 1001 mm / H min: 601 mm

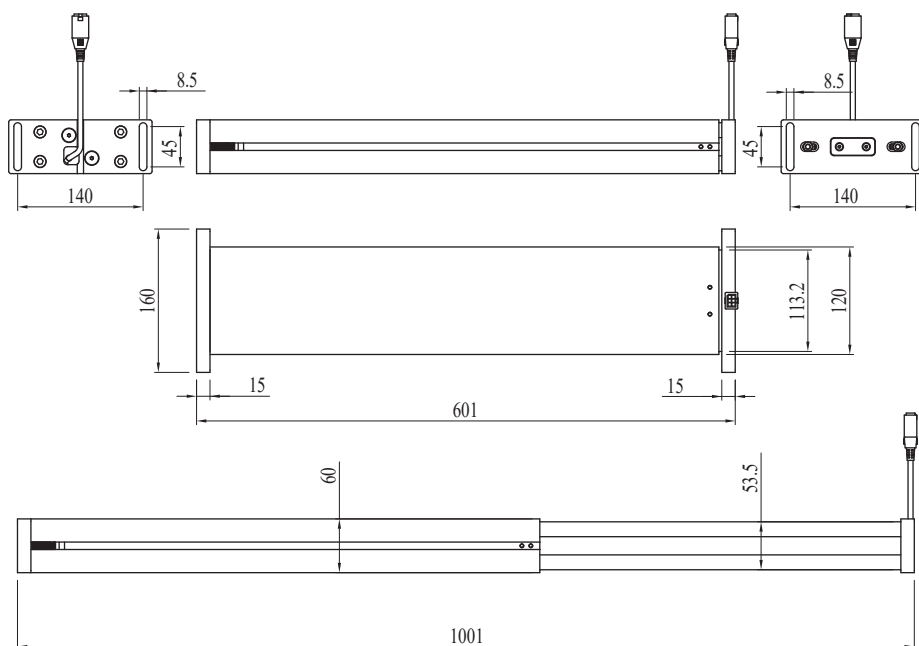
COLONNA DI SOLLEVAMENTO TELESOPICA
COLUMNA DE ELEVACIÓN TELESÓPICA
COLONNE DE LEVAGE TÉLESCOPIQUE

- EN** 135.070.400.2 is a two-stage telescopic lifting column. The outer stage is a 60x120 profile with 8 slots..
- LT** 135.070.400.2 - dviejų pakopų teleskopinė kėlimo kolona. Išorinė pakopa yra 60x120 profilis su 8 plyšiais.
- ES** 135.070.400.2 es una columna de elevación telescópica de dos etapas. La etapa exterior es un perfil de 60x120 con ranuras de 8.
- FR** 135.070.400.2 est une colonne de levage télescopique à deux étages. L'étage extérieur est un profilé de 60x120 avec des rainures de 8.
- DE** 135.070.400.2 ist eine teleskopische Hubsäule mit zwei Stufen. Die äußere Stufe ist ein 60x120-Profil mit 8 Nuten.

Maximum thrust force / Didžiausia darbinė energija / Force maximale de poussée / Maximale Schubkraft	700 N
Speed (no load) / Greitis (be apkrovos) / Velocidad (sin carga) / Vitesse (à vide) / Geschwindigkeit (ohne Last)	38 mm/s
Type / Tipas / Tipo / Type / Typ	2-dalių
Retracted length / Ištrauktas ilgis / Longitud retraída / Longueur rétractée / Eingefahrene Länge	601 mm
Stroke / Eigaa / Carrera / Course / Hub	400 mm
Voltage / Voltai / Voltaje / Tension / Spannung	18 V/DC
Maximum power / Maks. jėga / Potencia máxima / Puissance maximale / Maximale Leistung	180 W
Maximum current draw / Maks. srovė / Consumo máximo / Consommation maximale / Maximaler Stromverbrauch	10 A
Cable length / Kabelio ilgis / Longitud del cable / Longueur du câble / Kabellänge	200 mm
Duty cycle / Darbo ciklas / Ciclo de trabajo / Cycle de travail / Einschaltdauer	10%
Operating temperature/ Darbo temperat. / Temperatura de funcionamiento / Température de fonctionnement / Betriebstemperatur	+10 / +40 °C
Protection rating / Apsaugos klasė / Índice de protección / Indice de protection / Schutzart	iki 54
Insulation class / Izoliacijos klasė / Clase de aislamiento / Classe d'isolation / Isolationsklasse	III
Weight / Svoris / Peso / Poids / Gewicht	5,3 Kg
Integrated end stops / Integruoti galiniai ribotuvai / Finales de carrera integrados / Fins de course intégrés / Integrierte Endschalter	taip



3 DALIŲ TELESKOPINĖ KĖLIMO KOLONA

135.070.660.3

H max: 1193 mm / H min: 533 mm



COLONNA DI SOLLEVAMENTO TELESOPICA
COLUMNA DE ELEVACIÓN TELESÓPICA
COLONNE DE LEVAGE TÉLESCOPIQUE
TELESKOPISCHE HUBSÄULE

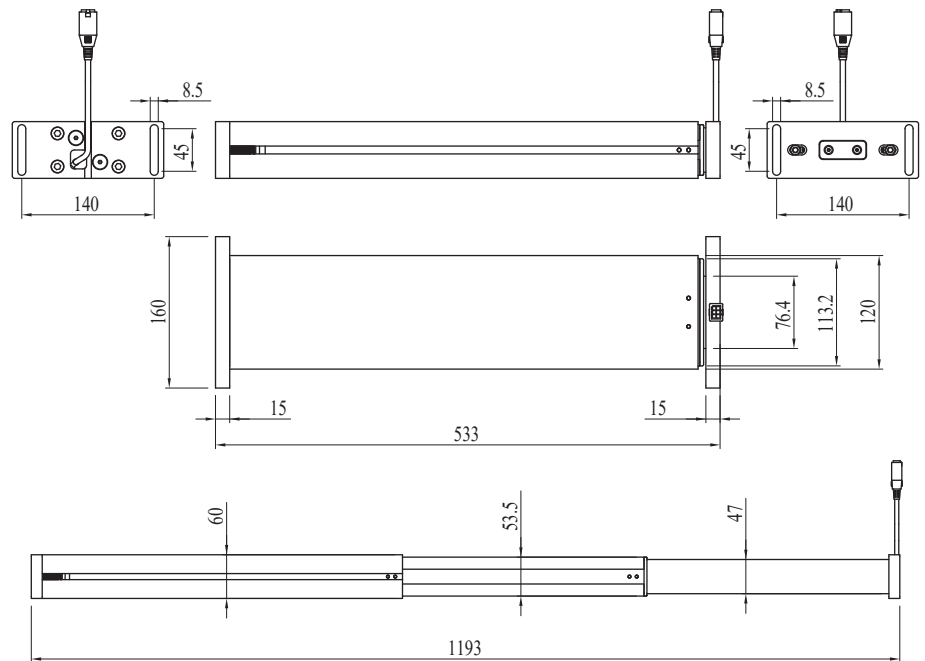

- EN** 135.070.660.3 is a three-stage telescopic lifting column. The outer stage is a 60x120 profile with 8 slots.
- LT** 135.070.660.3 - trijų pakopų teleskopinė kėlimo kolona. Išorinė pakopa yra 60x120 profilis su 8 grioveliais..
- ES** 135.070.660.3 es una columna de elevación telescópica de tres etapas. La etapa exterior es un perfil de 60x120 con ranuras de 8.
- FR** 135.070.660.3 est une colonne de levage télescopique à trois étages. L'étage extérieur est un profilé de 60x120 avec des rainures de 8.
- DE** 135.070.660.3 ist eine teleskopische Hubsäule mit drei Stufen. Die äußere Stufe ist ein 60x120-Profil mit 8 Nuten.

Maximum thrust force / Maksimali traukos jėga / Didžiausia darbinė energija / Force maximale de poussée / Maximale Schubkraft	700 N
Speed (no load) / Greitis (neapkrautas) / Velocidad (sin carga) / Vitesse (à vide) / Geschwindigkeit (ohne Last)	38 mm/s
Type / Tipas / Tipo / Type / Typ	3-dalių
Retracted length / Ištrauktas ilgis / Longitud retraída / Longueur rétractée / Eingefahrene Länge	533 mm
Stroke / Eiga / Carrera / Course / Hub	660 mm
Voltage / Voltai/ Voltaje / Tension / Spannung	18 V/DC
Maximum power / Maks. galia / Potencia máxima / Puissance maximale / Maximale Leistung	180 W
Maximum current draw / Maks srovė / Consumo máximo / Consommation maximale / Maximaler Stromverbrauch	10 A
Cable length / Kabelio ilgis / Longitud del cable / Longueur du câble / Kabellänge	200 mm
Duty cycle / Darbo ciklas / Ciclo de trabajo / Cycle de travail / Einschaltdauer	10%
Operating temperature/ Darbo temperatūra/ Temperatura de funcionamiento / Température de fonctionnement / Betriebstemperatur	+10 / +40 °C
Protection rating / Saugos lygis/ Índice di protezione / Índice de protección / Indice de protection / Schutzart	iki 54
Insulation class / Izoliacijos klasė / Clase de aislamiento / Classe d'isolation / Isolationsklasse	III
Weight / Svoris / Peso / Poids / Gewicht	5,6 Kg
Integrated end stops / Integruoti galiniai ribotuvai / Finales de carrera integrados / Fins de course intégrés / Integrierte Endschalter	Taip



200 W VALDYMO BLOKAS

CENTRALINA 200W
UNIDAD DE CONTROL DE 200W
CENTRALE DE 200W
200W-STEUERGERÄT

Kodas	Pastaba	g
135.401.001	2 channels 230 V AC, 50Hz - 2 kanalai 230 V AC, 50Hz - 2 canales 230 V CA, 50Hz - 2 canaux 230 V CA, 50Hz - 2 Kanäle 230 V AC, 50Hz	400

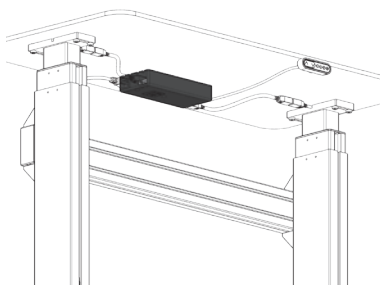
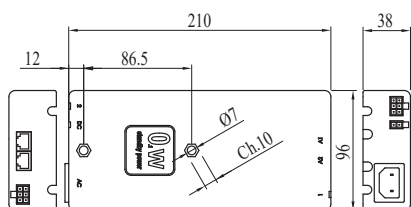

300 W VALDYMO BLOKAS

CENTRALINA 300W
UNIDAD DE CONTROL DE 300W
CENTRALE DE 300W
300W-STEUERGERÄT

Kodas	Pastaba	g
135.401.002	4 channels 100-240 V AC, 50-60Hz - 4 kanalai 100-240 V AC, 50-60Hz - 4 canales 100-240 V CA, 50-60Hz - 4 canaux 100-240 V CA, 50-60Hz - 4 Kanäle 100-240 V AC, 50-60Hz	500

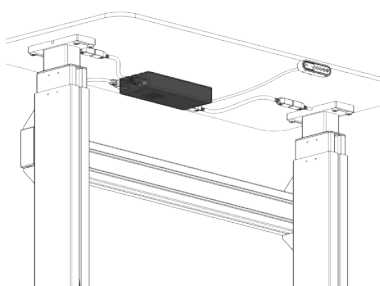
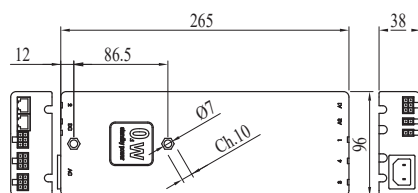



LOAD SPEED GRAPHS CONTROL UNITS

KOLONOS KĖLIMO GREIČIO DIAGRAMOS/ GRÁFICOS DE VELOCIDAD DE CARGA UNIDADES DE CONTROL
GRAPHIQUES DE VITESSE DE CHARGE CENTRALES / LASTGESCHWINDIGKEITSDIAGRAMME STEUERGERÄTE

2x 135.070 - With 135.400.001 or 135.400.002 /

Su 135.400.001 ar 135.400.002 / Con 135.400.001 o 135.400.002 / Avec 135.400.001 ou 135.400.002 / Mit 135.400.001 oder 135.400.002

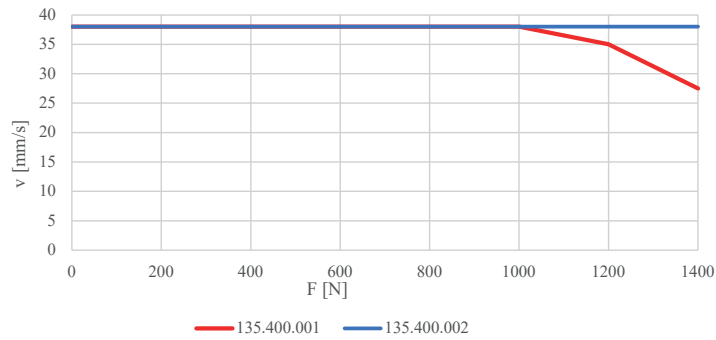

3x 135.070 - With 135.400.002

Su 135.400.002 / Con 135.400.002 / Avec 135.400.002 / Mit 135.400.002

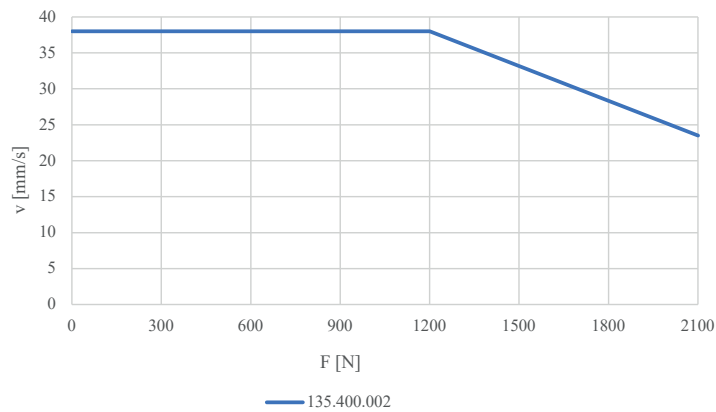

4x 135.070 - With 135.400.002

Su 135.400.002 / Con 135.400.002 / Avec 135.400.002 / Mit 135.400.002

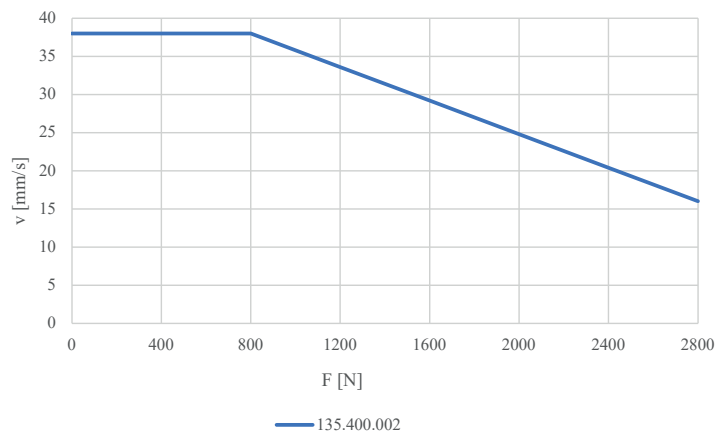



VALDYMO SKYDELIS

PANNELLO DI CONTROLLO
PANEL DE CONTROL
PANNEAU DE CONTRÔLE
BEDIENFELD

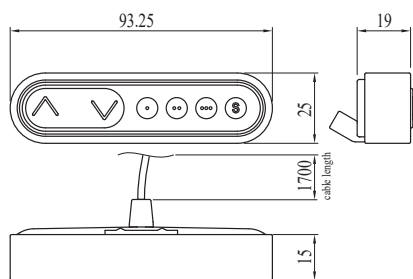

Kodas	Pastaba	g
135.401.101	With 3 memory slots for pre-programmed positions / Su 3 atminties lizdais iš anksto užprogramuotoms pozicijoms / Con 3 ranuras de memoria para posiciones preprogramadas / Avec 3 emplacements mémoire pour positions préprogrammées / Mit 3 Speicherslots für vorprogrammierte Positionen	80

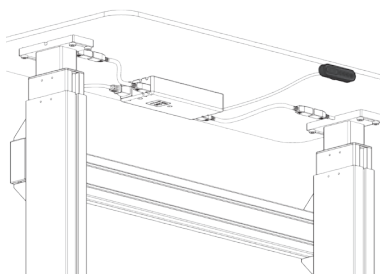

VALDYMO SKYDELIO MONTAVIMO LAIKIKLIS

STAFFA DI FISSAGGIO PANNELLO DI CONTROLLO
SOPORTE DE MONTAJE DEL PANEL DE CONTROL
SUPPORT DE FIXATION POUR PANNEAU DE CONTRÔLE
HALTERUNG FÜR BEDIENFELD

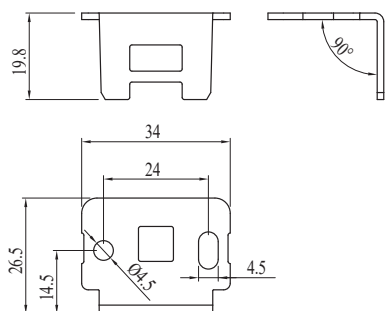

Kodas	Pastaba	g
135.401.102	-	13

Galvanised steel
Cinkuotas plienas
Acero galvanizado
Acier zingué
Verzinkter Stahl

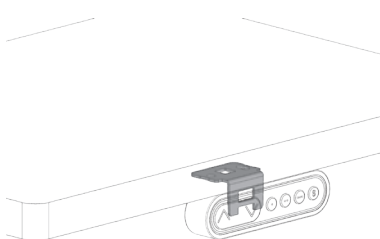



VARIKLIO LAIDAS

CAVO MOTORE
CABLE DE MOTOR
CÂBLE MOTEUR
MOTORKABEL

Kodas	Pastaba	g
135.401.201.1000	L=1000mm	55

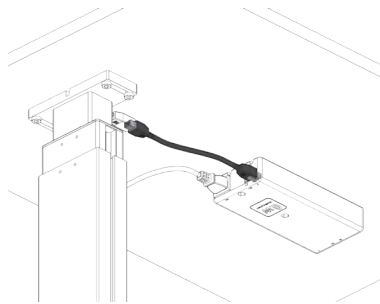

GALIOS KABELIS

CAVO ALIMENTAZIONE
CABLE DE ALIMENTACIÓN
CÂBLE D'ALIMENTATION
STROMKABEL

Kodas	Pastaba	g
135.401.202	L=2000mm	180

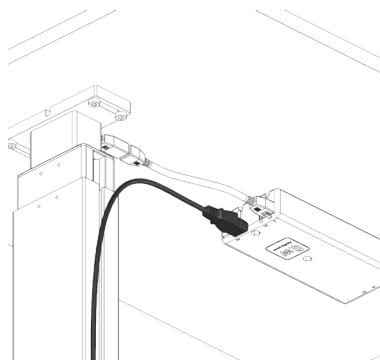



KĖLIMO KOLONŲ PAGRINDAS

BASE PER COLONNE DI SOLLEVAMENTO
BASE PARA COLUMNAS DE ELEVACIÓN
BASE POUR COLONNES DE LEVAGE
BASIS FÜR HUBKOLONNEN

Kodas	Pastaba	g
135.301.007	-	1400



Galvanised steel
Cinkuotas plienas
Acero galvanizado
Acier zingué
Verzinkter Stahl

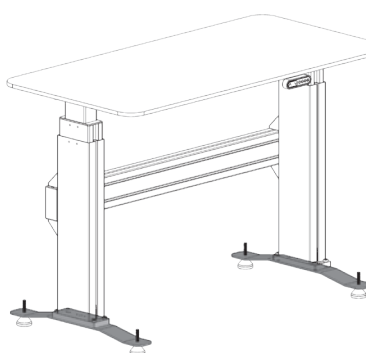
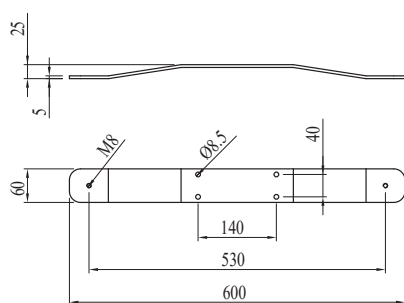



TAIKYMO PAVYZDYS
ESEMPIO APPLICATIVO / EJEMPLO DE
APLICACIÓN EJEMPLO D'APPLICATION /

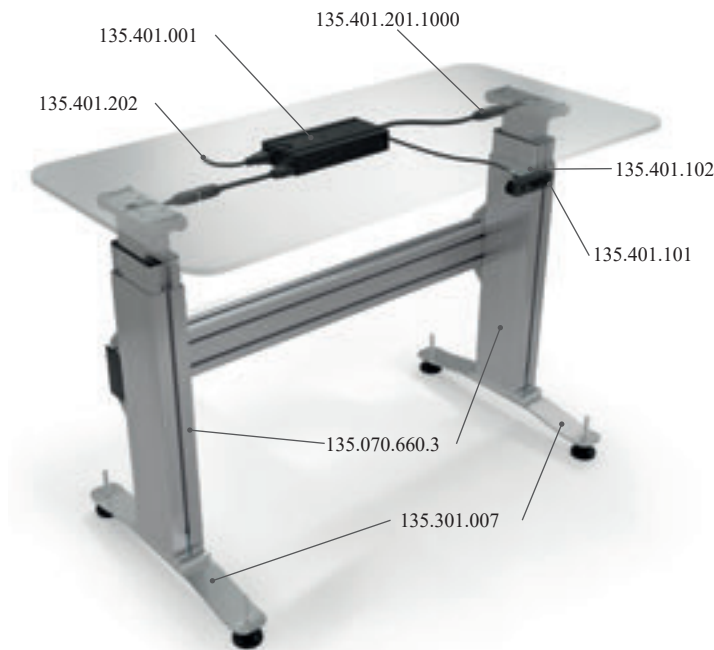

maks aukštis 1193mm
135.070.660.3 maks
aukštis 1001mm
135.070.400.2

min aukštis 601mm
135.070.660.3
min aukštis 533mm
135.070.400.2

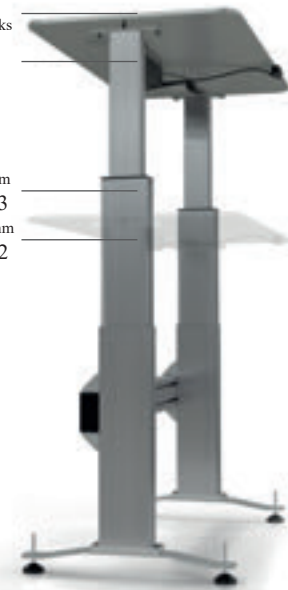

Height-adjustable workbench, with two three-stage telescopic columns. Complete with control panel and power supply
Reguliuojamo aukščio darbastalis su dviem trijų pakopų teleskopinėmis kolonomis. Komplekte yra valdymo pultas ir maitinimo šaltinis.
Mesa de trabajo ajustable en altura, con dos columnas telescópicas de tres etapas. Completo con panel de control y fuente de alimentación. Plan de travail réglable en hauteur, avec deux colonnes télescopiques à trois niveaux. Complet avec boîtier de commande et alimentation. Höhenverstellbare Arbeitsplatte mit zwei dreistufigen Teleskopsäulen. Komplett mit Bedienfeld und Netzteil.

CONTROL PANEL FUNCTIONS
VALDYMO PULTO FUNKCIJOS / FUNCIONES DEL PANEL DE CONTROL
FONCTIONS DU PANNEAU DE CONTRÔLE / FUNKTIONEN DES BEDIENFELDS

The control panel allows you to set the desired table height and save up to three positions
Valdymo pultas leidžia nustatyti norimą stalo aukštį ir išsaugoti iki trijų pozicijų.
El panel de control permite ajustar la altura deseada de la mesa y guardar hasta tres posiciones.
Le panneau de contrôle permet de régler la hauteur souhaitée du plan de travail et de mémoriser jusqu'à trois positions. Das Bedienfeld ermöglicht es, die gewünschte Tischhöhe einzustellen und bis zu drei Positionen zu speichern.

Norėdami išsaugoti iš anksto užprogramuotą aukštį, paspauskite mygtuką „S“. Tada per kitas dvi sekundes paspauskite vieną iš „Mem“ mygtukų.

Per memorizzare un'altezza preprogrammata, premere il tasto "S". Poi, nei seguenti due secondi, uno dei tasti "Mem".

Para guardar una altura preprogramada, presione el botón "S". Luego, dentro de los siguientes dos segundos, presione uno de los botones "Mem".

Pour mémoriser une hauteur préprogrammée, appuyez sur le bouton "S". Ensuite, dans les deux secondes suivantes, appuyez sur l'un des boutons "Mem".

Um eine vorprogrammierte Höhe zu speichern, drücken Sie die Taste "S". Drücken Sie dann innerhalb der nächsten zwei Sekunden eine der "Mem"-Tasten.

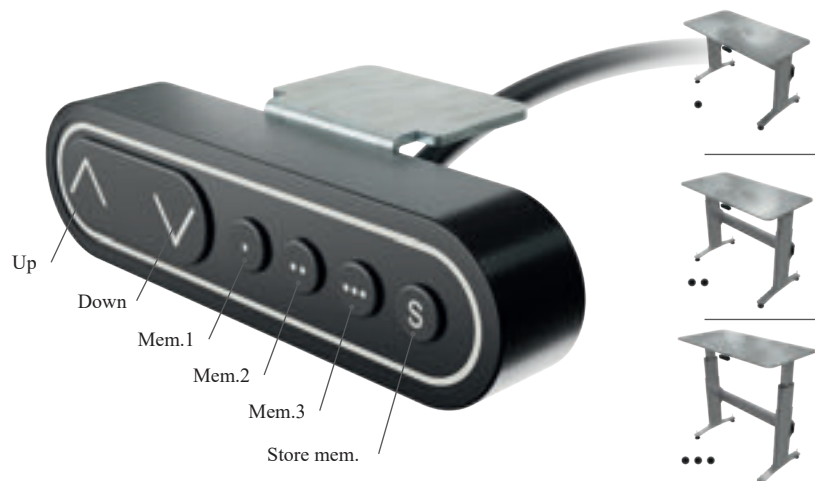



**CENTRINIO TVIRTINIMO
PASISUKANTIS RATUKAS Ø60**

RUOTA GIREVOLE
RUEDA GIRATORIA
ROULETTE PIVOTANTE
LENKROLLE

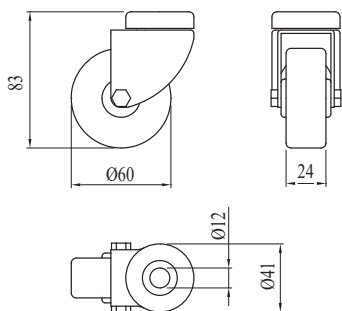

Kodas	Pastaba	g
084.404.001	Central screw fastening - Centrinis tvirtinimas varžtu - Fijación con tornillo central - Fixation à vis centrale - Befestigung mittels mittlerer Schraube	228

Rubber wheel
Guminis ratukas
Rueda de goma
Roue en caoutchouc
Rad aus Gummi
50Kg

Chromed steel bracket
Chromuotas plieninis laikiklis
Soporte de acero cromado
Support en acier chromé
Halterung aus verchromtem Stahl

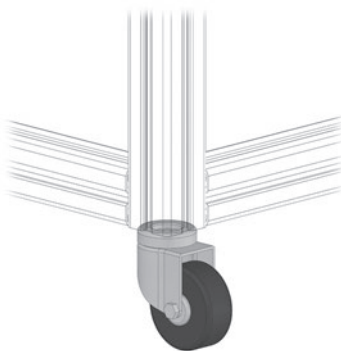

**FLANŠINIO TVIRTINIMO
PASISUKANTIS RATUKAS Ø60**

RUOTA GIREVOLE
RUEDA GIRATORIA
ROULETTE PIVOTANTE
LENKROLLE

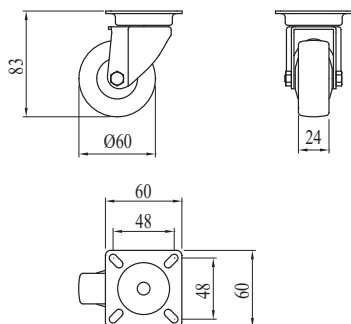

Kodas	Pastaba	g
084.404.006	Flange fastening - Flanšinis tvirtinimasa - Fijación con brida - Fixation à bride - Befestigung mittels Flansch	330

Rubber wheel
Guminis ratukas
Rueda de goma
Roue en caoutchouc
Rad aus Gummi
50Kg

Chromed steel bracket
Chromuotas plieninis laikiklis
Soporte de acero cromado
Support en acier chromé
Halterung aus verchromtem Stahl

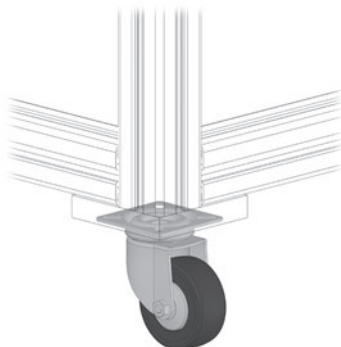



CENTRINIO TVIRTINIMO PASISUKANTIS RATUKAS Ø60 SU STABDŽIU

RUOTA GIREVOLE CON FRENO
RUEDA GIRATORIA CON FRENO
ROULETTE PIVOTANTE AVEC FREIN
LENKROLLE MIT FESTSTELLER

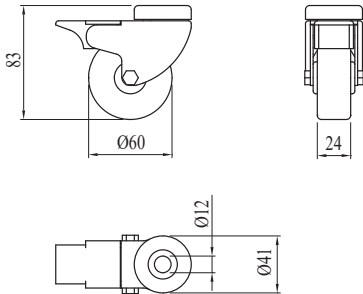

Kodas	Pastaba	g
084.404.003	Central screw fastening and brake - Centrinis tvirtinimas varžtu su stabdžiu - Fijación con tornillo central y freno - Fixation à vis centrale et frein - Befestigung mittels mittlerer Schraube und Bremse	330

Rubber wheel
Guminis ratukas
Rueda de goma
Roue en caoutchouc
Rad aus Gummi
50Kg

Chromed steel bracket
Chromuotas plieninis laikiklis
Soporte de acero cromado
Support en acier chromé
Halterung aus verchromtem Stahl

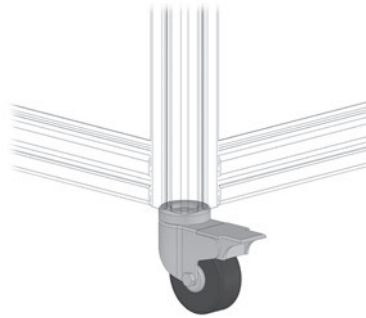

FLANŠINIO TVIRTINIMO PASISUKANTIS RATUKAS Ø60 SU STABDŽIU

RUOTA GIREVOLE CON FRENO
RUEDA GIRATORIA CON FRENO

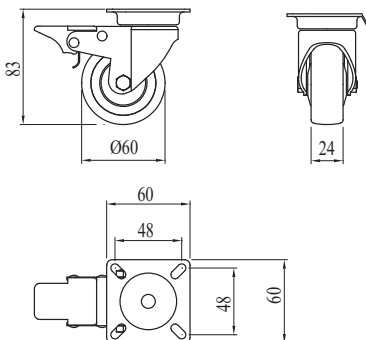

Kodas	Pastaba	g
084.404.008	Flange fastening and brake - Flanšinis tvirtinimas su stabdžiu - Fijación con brida y freno - Fixation à bride et frein - Befestigung mittels Flansch und Bremse	400

Rubber wheel
Guminis ratukas
Rueda de goma
Roue en caoutchouc
Rad aus Gummi
50Kg

Chromed steel bracket
Chromuotas plieninis laikiklis
Soporte de acero cromado
Support en acier chromé
Halterung aus verchromtem Stahl

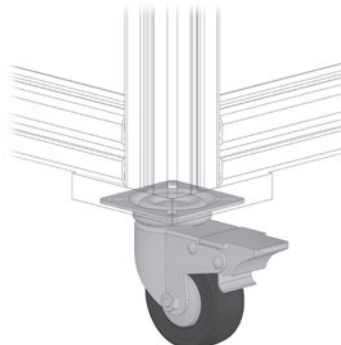



**FLANŠINIO TVIRTINIMO
PASISUKANTIS RATUKAS Ø60**

RUOTA GIREVOLE
RUEDA GIRATORIA
ROULETTE PIVOTANTE LENKROLLE

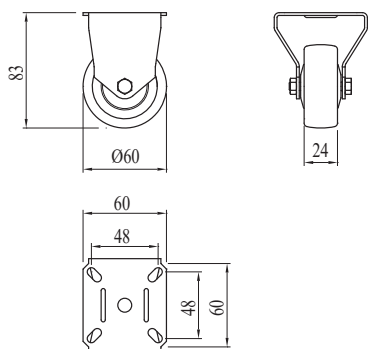

Kodas	Pastaba	g
084.404.007	Flange fastening - Flanšinis tvirtinimas - Fijación con brida - Fixation à bride - Befestigung mittels Flansch	260

Rubber wheel
Guminis ratukas
Rueda de goma
Roue en caoutchouc
Rad aus Gummi
50Kg

Chromed steel bracket
Chromuotas plieninis laikiklis
Soporte de acero cromado
Support en acier chromé
Halterung aus verchromtem Stahl

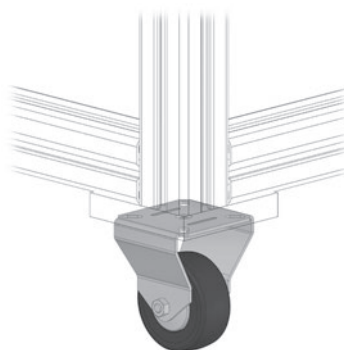



FLANŠINIO TVIRTINIMO PASISUKANTIS RATUKAS Ø100

RUOTA GIREVOLE
RUEDA GIRATORIA
ROULETTE PIVOTANTE LENKROLLE

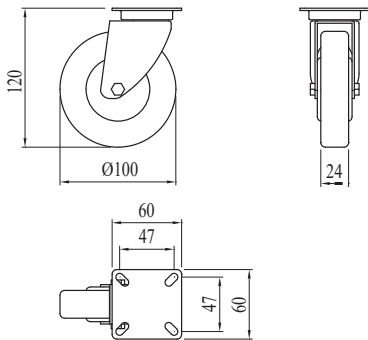

Kodas	Pastaba	g
084.404.002	Flange fastening - Flanšinis tvirtinimas - Fijación con brida - Fixation à bride - Befestigung mittels Flansch	427

Rubber wheel
Guminis ratukas
Rueda de goma
Roue en caoutchouc
Rad aus Gummi
55Kg

Chromed steel bracket
Chromuotas plieninis laikiklis
Soporte de acero cromado
Support en acier chromé
Halterung aus verchromtem Stahl

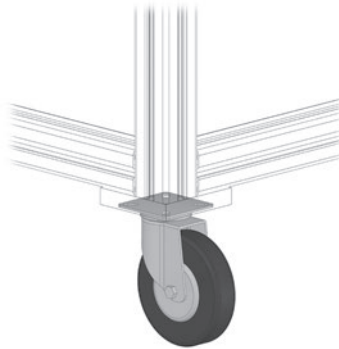

FLANŠINIO TVIRTINIMO PASISUKANTIS RATUKAS Ø100, SU STABDŽIU

RUOTA GIREVOLE CON FRENO
RUEDA GIRATORIA CON FRENO
ROULETTE PIVOTANTE AVEC FREIN
LENKROLLE MIT FESTSTELLER

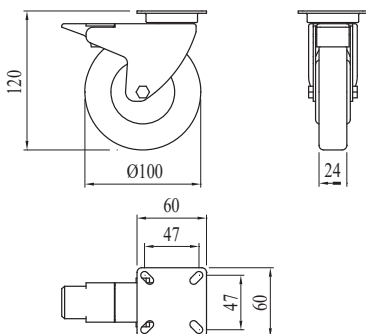

Kodas	Pastaba	g
084.404.004	Flange fastening and brake - Flanšinis tvirtinimas su stabdžiu - Fijación con brida y freno - Fixation à bride et frein - Befestigung mittels Flansch und Bremse	487

Rubber wheel
Guminis ratukas
Rueda de goma
Roue en caoutchouc
Rad aus Gummi
55Kg

Chromed steel bracket
Chromuotas plieninis laikiklis
Soporte de acero cromado
Support en acier chromé
Halterung aus verchromtem Stahl

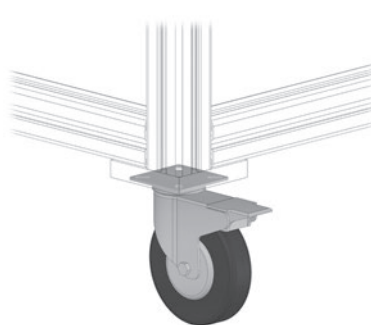



FLANŠINIO TVIRTINIMO PASISUKANTIS RATUKAS Ø100

RUOTA GIREVOLE
RUEDA GIRATORIA
ROULETTE PIVOTANTE LENKROLLE

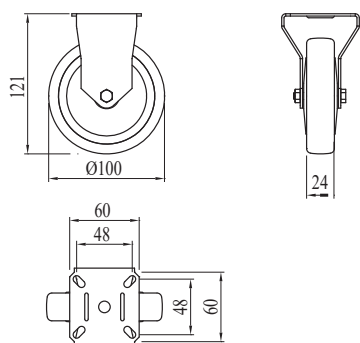

Kodas	Pastaba	g
084.404.009	Flange fastening - Flanšinis tvirtinimas - Fijación con brida - Fixation à bride - Befestigung mittels Flansch	400

Rubber wheel
Guminis ratukas
Rueda de goma
Roue en caoutchouc
Rad aus Gummi
55Kg

Chromed steel bracket
Chromuotas plieninis laikiklis
Soporte de acero cromado
Support en acier chromé
Halterung aus verchromtem Stahl

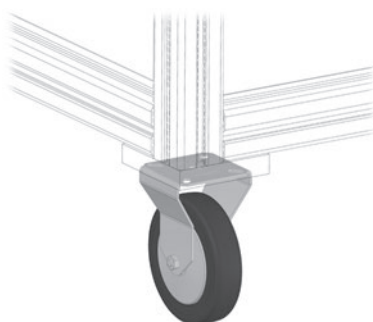

PASISUKANTIS RATUKAS SU STABDŽIU Ø100

RUOTA GIREVOLE CON FRENO
RUEDA GIRATORIA CON FRENO
ROULETTE PIVOTANTE AVEC FREIN
LENKROLLE MIT FESTSTELLER

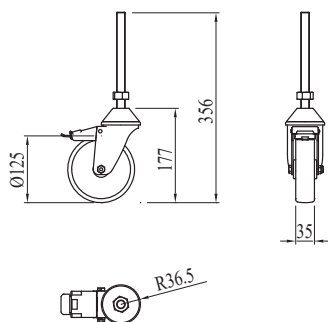

Kodas	Pastaba	g
084.404.005	Fastening with M16 pin and brake - Tvirtinimas M16 kaiščiu ir stabdžiu - Fijación con perno M16 y freno - Fixation avec pivot M16 et frein - Befestigung mit Bolzen M16 und Bremse	1500

Rubber wheel
Guminis ratukas
Rueda de goma
Roue en caoutchouc
Rad aus Gummi
180Kg

Stainless steel bracket
Supporto in nerūdijantis plienas
Soporte de acero inoxidable
Support en acier chromé
Halterung aus rostfreiem Stahl

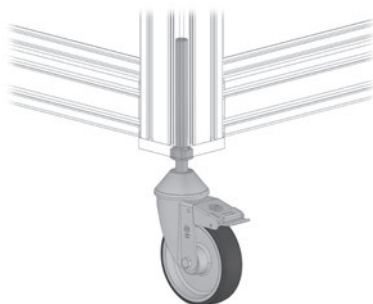



STOP RIEDĖJIMUI

FERMO PER CARRELLO
RETÉN PARA CARRO
BUTÉE POUR CHARIOT
FESTSTELLER FÜR WAGEN



Kodas	Pastaba	g
511.011.000R	E	69
511.011.000B	D	69
511.011.000V	F	69
511.011.000G	G	69

Polyamide
Poliamidas
Poliamida
Polyamide
Polyamid

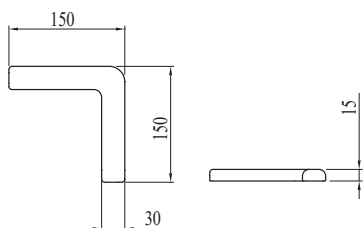



SAUGUS SKYDŲ TVIRTINIMO FIKSATORIUS

PATENT



FISSAGGIO PANNELLI CON SICUREZZA
FIJACIÓN PANELES CON SEGURIDAD
FIXATION PANNEAUX AVEC SÉCURITÉ
PLATTENBEFESTIG. MIT SICHERHEITSEINRICHTUNG



Table with 3 columns: Kodas, Pastaba, g. Row 1: 084.407.003, Kit with quick release fastener and safety ejector - Kompletas su greito atleidimo ir apsauginiais išmetikliais - Kit con cierre rápido y expulsores de seguridad - Kit à fermeture rapide et dispositifs d'expulsion de sécurité - Kit mit Schnellverschluss und Sicherheitsauswerfern, 331

Pilkas poliamidas
Poliamidas pilkas
Poliamida color gris
Polyamide gris
Polyamid grau

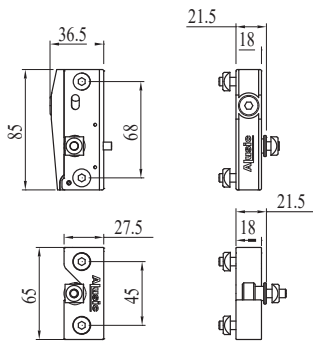

APERTURA: RUOTARE IN SENSO ANTIORARIO
OPENING: ROTATE COUNTERCLOCKWISE
APERTURA: GIRAR EN EL SENTIDO ANTIHORARIO
OUVERTURE: TOURNER DANS LE SENS ANTI-HORAIRE
ÖFFNUNG: DREHUNG ENGEGEN DEM UHRZEIGERSINN



CHIUSURA: RUOTARE IN SENSO ORARIO
CLOSING: ROTATE CLOCKWISE
CERRE: GIRAR EN EL SENTIDO HORARIO
FERMETURE: TOURNER DANS LE SENS HORAIRE
VERSCHLUSS: DREHUNG IM UHRZEIGERSINN



GREITO SKYDŲ TVIRTINIMO FIKSATORIUS

FISSAGGIO PANNELI RAPIDO FIJACIÓN DE
PANELES RÁPIDO FIXATION RAPIDE PANNEAUX
SCHNELLBESTIGUNG PLATTEN

BH 10 L 40 BH L 10 45 BH H 10 45 BH 10 50



Kodas	Pastaba	g
084.407.010	Complete with bushing - Komplektuojama su įvore - Incluye casquillo - Doté de douille - Einschließlich Buchse	47

Anodised aluminium
Anodizuotas aliuminis
Aluminium anodisé
Eloxiertes Aluminium
L=6040 mm

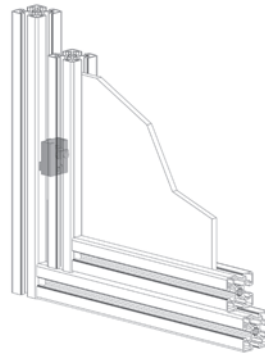
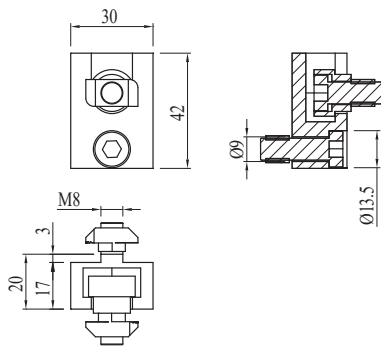



REGULIUOJAMAS TVIRTINIMO DETALIŲ BLOKAS 12x29

BLOCCHETTO DI FISSAGGIO REGOLABILE
BLOQUE DE FIJACIÓN REGULABLE
BLOC DE FIXATION RÉGLABLE
EINSTELLBARER BEFESTIGUNGSBLOCK

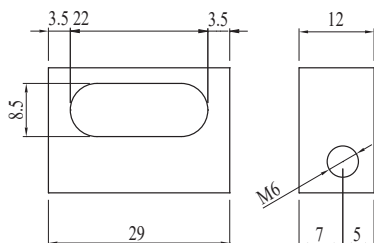

Kodas	Pastaba	g
084.507.001	Panel thickness 1-8 mm - Plokštės storis 1-8 mm - Grosor de los paneles 1-8 mm - Épaisseur panneaux 1-8 mm - Plattendicke 1-8 mm	10

Sandblasted aluminium
Smėliapūte apdorotas aliuminis
Aluminio arenado
Aluminium sablé
Sandgestrahltes Aluminium

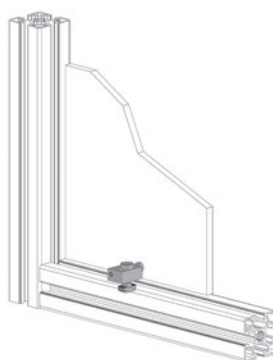

TRIKAMPIS STIKLO FIKSAVIMO BLOKAS

BLOCCHETTO FERMAVETRO
BLOQUE SUJETA-CRISTAL
BLOC DE FIXATION VERRE SCHEIBENSTOPPERBLOCK

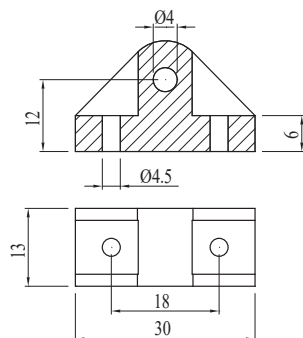

Kodas	Pastaba	g
084.509.001	Panel thickness 1-8 mm - Plokštės storis 1-8 mm - Grosor de los paneles 1-8 mm - Épaisseur panneaux 1-8 mm - Plattendicke 1-8 mm	4

Pilkas poliamidas
Poliamidas pilkas
Poliamida color gris
Polyamide gris
Polyamid grau

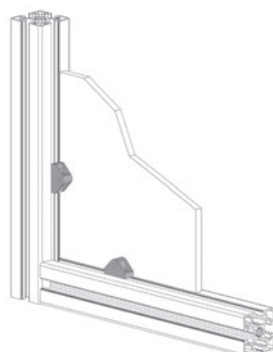



STIKLO FIKSAVIMO POVERŽLĖ

RONDELLA FERMAVETRO
 ARANDELA SUJETA-CRISTAL
 RONDELLE DE FIXATION VERRE
 SCHEIBENSTOPPERRING

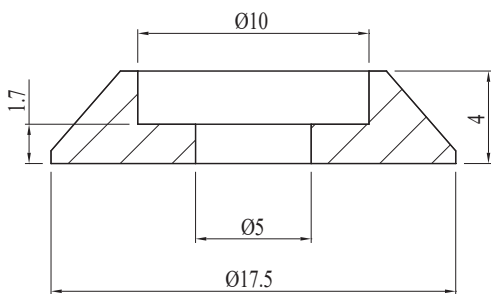

Kodas	Pastaba	g
084.509.002	For 084.509.001 - Su 084.509.001 - Para 084.509.001 - Pour 084.509.001 - Für 084.509.001	1

Pilkas poliamidas
 Poliamidas pilkas
 Poliamida color gris
 Polyamide gris
 Polyamid grau

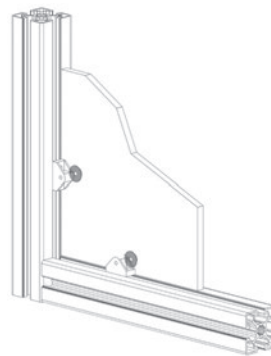

STIKLO TVIRTINIMO SPAUSTUVAS

MORSETTO PANNELLO IN VETRO
 MORDAZA PANEL DE VIDRIO
 PINCE DE FIXATION PANNEAU EN VERRE
 KLEMME FÜR GLASSCHEIBE

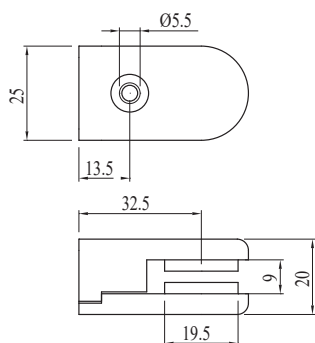

Kodas	Pastaba	g
084.509.003	Panel thickness 2-10 mm - Plokštės storis 2-10 mm - Grosor de los paneles 2-10 mm - Épaisseur panneaux 2-10 mm - Plattendicke 2-10 mm	74

Zamak
 Zamak
 Zamak
 Zamak
 Zamak

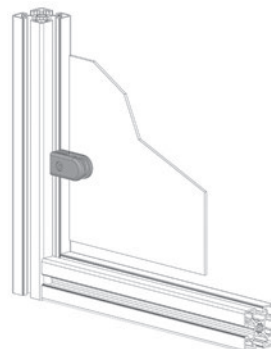



TVIRTINIMO DETALIŲ BLOKAS

BLOCCHETTO DI FISSAGGIO
BLOQUE DE FIJACIÓN
BLOC DE FIXATION
BEFESTIGUNGSBLOCK

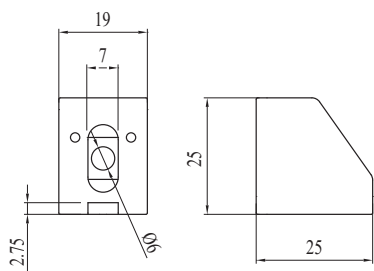

Kodas	Pastaba	g
084.510.001	Panel thickness 1-8 mm - Plokštės storis 1-8 mm - Grosor de los paneles 1-8 mm - Épaisseur panneaux 1-8 mm - Plattendicke 1-8 mm	10

Black polyamide
Juodas poliamidas
Poliamida color negro
Polyamide noir
Polyamid schwarz

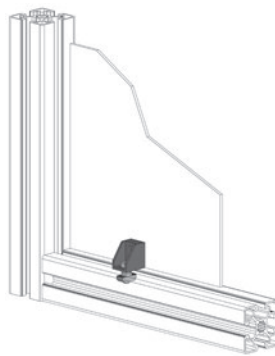

SANDARIKLIS PRIE 084.510.001

DISTANZIALE PER 084.510.001
DISTANCIADOR PARA 084.510.001
ENTRETOISE POUR 084.510.001
DISTANZSTÜCK FÜR 084.510.001

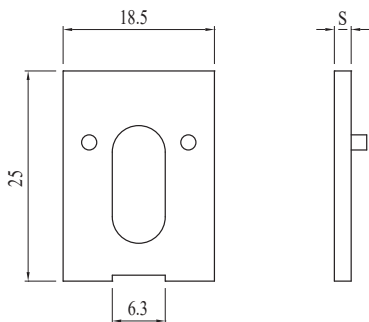

Kodas	Pastaba	g
084.510.002	2 mm	1
084.510.003	3 mm	1
084.510.004	5 mm	2

Black polyamide
Juodas poliamidas
Poliamida color negro
Polyamide noir
Polyamid schwarz

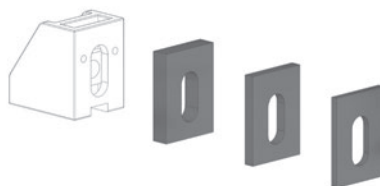



TVIRTINIMO DETALIŲ BLOKAS

BLOCCETTO DI FISSAGGIO
BLOQUE DE FIJACIÓN
BLOC DE FIXATION
BEFESTIGUNGSBLOCK



Kodas	Pastaba	g
084.510.009	Complete with M6 nut - Komplekte su M6 veržle - Incluye tuerca M6 - Doté d'écrou M6 - Ein schließlich Mutter M6	10

Pilkas poliamidas
Poliamidas pilkas
Poliamida color gris
Polyamide gris
Polyamid grau

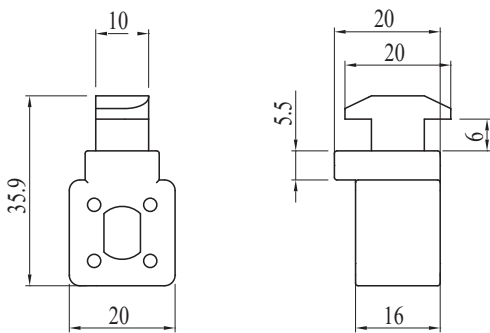

SANDARIKLIS PRIE 084.510.009

DISTANZIALE PER 084.510.009
DISTANCIADOR PARA 084.510.009
ENTRETOISE POUR 084.510.009
DISTANZSTÜCK FÜR 084.510.009



Kodas	Pastaba	g
084.510.010	2 mm	1
084.510.011	3 mm	1
084.510.012	5 mm	2

Pilkas poliamidas
Poliamidas pilkas
Poliamida color gris
Polyamide gris
Polyamid grau

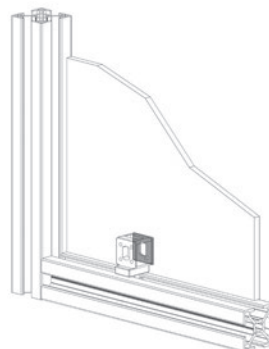
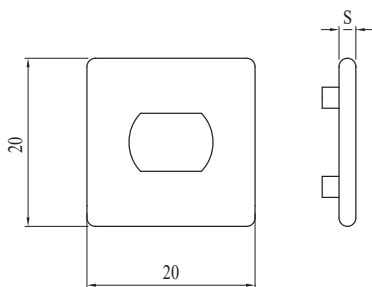



TVIRTINIMO DETALIŲ BLOKAS



BLOCCHETTO DI FISSAGGIO
BLOQUE DE FIJACIÓN
BLOC DE FIXATION
BEFESTIGUNGSBLOCK



Kodas	Pastaba	g
084.510.017	M6 nut included - Komplekte su veržle M6 - Tuerca M6 incluida - Écrou M6 inclus - Nutenstein M6 im Lieferumfang enthalten	11

Black polyamide
Juodas poliamidas
Poliamida color negro
Polyamide noir
Polyamid schwarz

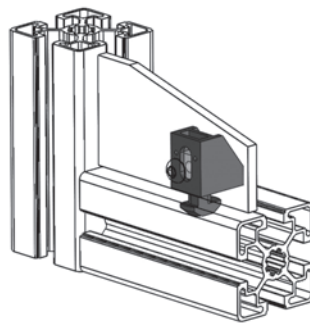
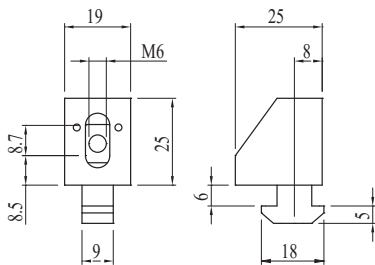

TVIRTINIMO DETALIŲ BLOKAS



BLOCCHETTO DI FISSAGGIO
BLOQUE DE FIJACIÓN
BLOC DE FIXATION
BEFESTIGUNGSBLOCK



Kodas	Pastaba	g
084.510.020	Interlock fastening - Blokavimo tvirtinimas - Fijación por encastre - Fixation par emboîtement - Klemm befestigung	10

Black polyamide
Juodas poliamidas
Poliamida color negro
Polyamide noir
Polyamid schwarz

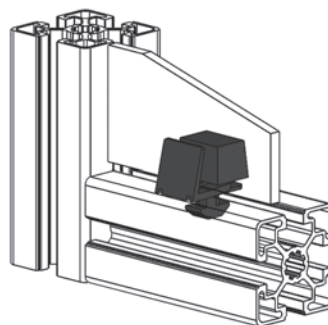
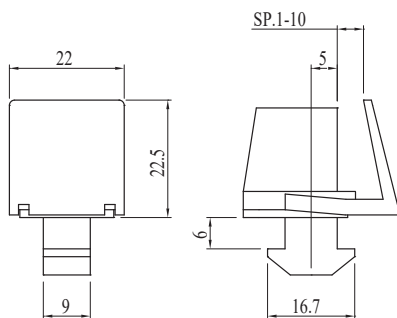



TVIRTINIMO DETALIŲ BLOKAS

BH
8
30

BLOCCHETTO DI FISSAGGIO
BLOQUE DE FIJACIÓN
BLOC DE FIXATION
BEFESTIGUNGSBLOCK



Kodas	Pastaba	g
084.519.003	For RH removable panels - RH nuimamoms plokštėms - Para paneles extraíbles derecha - Pour panneaux extractibles droite - Für herausziehbare Platten rechts	33

Pilkas poliamidas
Poliamidas pilkas
Poliamida color gris
Polyamide gris
Polyamid grau

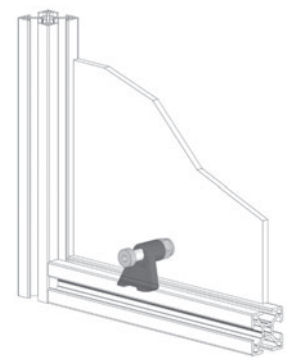
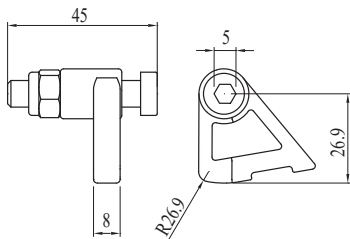

TVIRTINIMO DETALIŲ BLOKAS

BH
8
30

BLOCCHETTO DI FISSAGGIO
BLOQUE DE FIJACIÓN
BLOC DE FIXATION
BEFESTIGUNGSBLOCK



Kodas	Pastaba	g
084.519.004	For LH removable panels - LH nuimamoms plokštėms - Para paneles extraíbles izquierda - Pour panneaux extractibles gauche - Für herausziehbare Platten links	33

Pilkas poliamidas
Poliamidas pilkas
Poliamida color gris
Polyamide gris
Polyamid grau

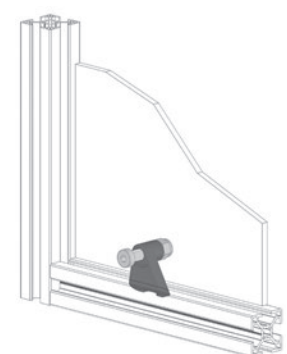
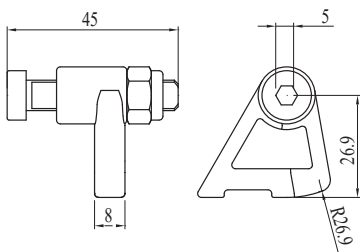



DAUGIAFUNKCIS ELEMENTAS



MULTIUSO
MULTIUSO
MULTIFONCTION
MEHRZWECKELEMENT

Kodas	Pastaba	g/m
084.514.013	L = 2 m	258



Juodas polietilenas
Polietyleno color negro
Polyéthylène noir
Polyethylen schwarz

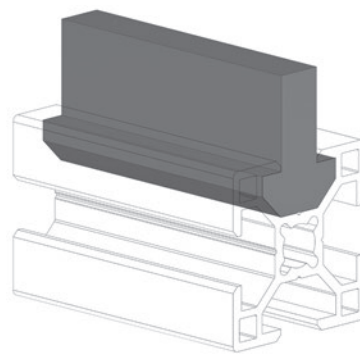
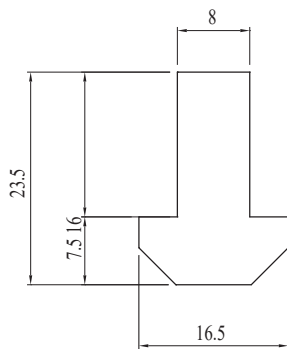

DAUGIAFUNKCIS ELEMENTAS



MULTIUSO
MULTIUSO
MULTIFONCTION
MEHRZWECKELEMENT

Kodas	Pastaba	g/m
084.514.014	L = 2 m	293



Juodas polietilenas
Polietyleno color negro
Polyéthylène noir
Polyethylen schwarz

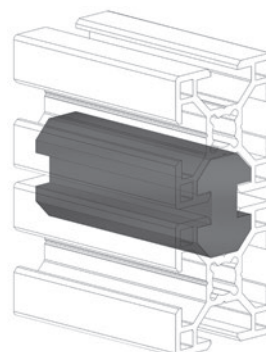
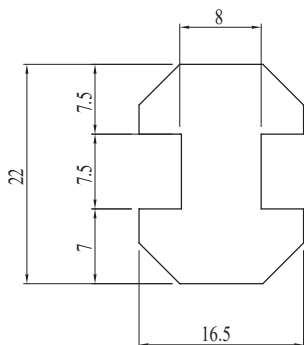



DAUGIAFUNKCIS ELEMENTAS

MULTIUSO
MULTIUSO
MULTIFONCTION
MEHRZWECKELEMENT

BH L BH H BH H
10 45 10 45 10 50

Kodas	Pastaba	g/m
084.514.012	L = 2 m	750



Juodas polietilenas
Polietileno color negro
Polyéthylène noir
Polyethylen schwarz

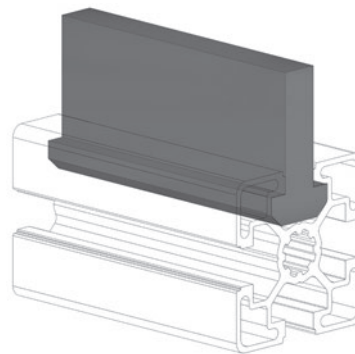
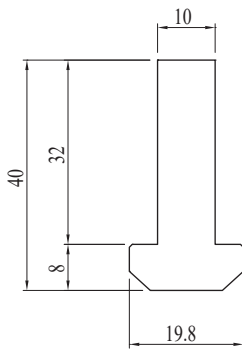

DAUGIAFUNKCIS ELEMENTAS

MULTIUSO
MULTIUSO
MULTIFONCTION
MEHRZWECKELEMENT

BH L BH H BH H
10 45 10 45 10 50

Kodas	Pastaba	g/m
084.514.016	L = 2 m	503



Juodas polietilenas
Polietileno color negro
Polyéthylène noir
Polyethylen schwarz

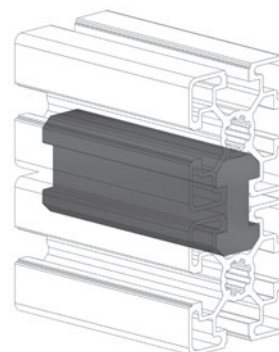
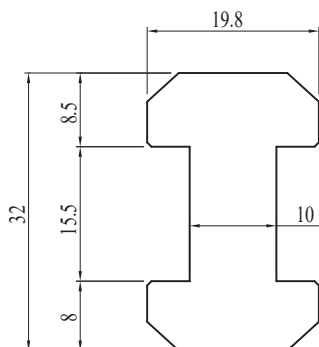



SKYDŲ TARPIKLIS

BH
6
20

GUARNIZIONE PER PANNELLO
JUNTA PARA PANEL
JOINT POUR PANNEAU
SCHEIBENDICHTUNG

Kodas	S	Sp.	S	g/m
084.512.003	2	A	200 m	50

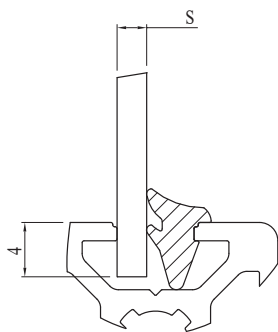

Thermoplastic rubber
Termoplastinė guma
Goma termoplástica
Caoutchouc thermoplastique
Thermoplastischer Gummi

SKYDŲ TARPIKLIS

BH
8
30

GUARNIZIONE PER PANNELLO
JUNTA PARA PANEL
JOINT POUR PANNEAU
SCHEIBENDICHTUNG

Kodas	S	Sp.	S	g/m
084.512.006	1	A	90 m	106
5004A/3170	2	A	120 m	100
084.512.004	3	A	150 m	64
084.512.003	4	A	200 m	50
084.512.056	5	A	125 m	34
084.512.056G	5	B	125 m	34
084.512.006G	1	B	90 m	106
084.512.006T	1	<input checked="" type="checkbox"/>	90 m	106

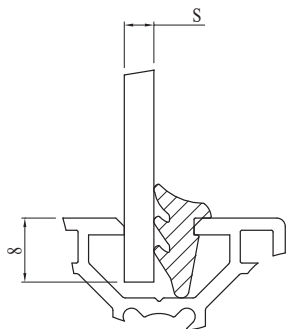

Thermoplastic rubber
Termoplastinė guma
Goma termoplástica
Caoutchouc thermoplastique
Thermoplastischer Gummi



SKYDŲ TARPIKLIS

BH 10 40	BH L 10 45	BH H 10 45	BH 10 50
----------------	------------------	------------------	----------------

GUARNIZIONE PER
PANNELLO JUNTA
PARA PANEL
JOINT POUR PANNEAU
SCHEIBENDICHTUNG

Kodas	S	Sp.	S	g/m
084.512.030	5	A	90 m	50
084.512.030G	5	B	90 m	50

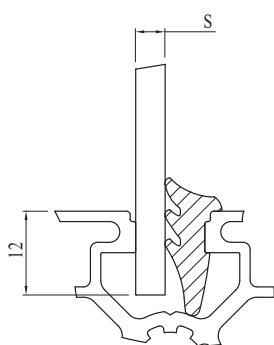

Thermoplastic rubber
Termoplastinė guma
Goma termoplástica
Caoutchouc thermoplastique
Thermoplastischer Gummi

TVIRTAS GRIOVELIO DANGTELIS

BH 8 30

CHIUDICAVA RIGIDO
TAPA-RANURA RÍGIDO
FERMETURE RAINURE RIGIDE
STARRES VERSCHLIESSELEMENT FÜR NUTEN

Kodas	Pastaba	g/m
084.203.024	Panel thickness: 2-4 mm - Plokštės storis: 2-4 mm - Grosor de los paneles: 2-4 mm - Épaisseur panneaux: 2-4 mm - Plattendicke: 2-4 mm	40



Rigid black PVC
Juodas kietas PVC
PVC rígido color negro
PVC rigide noir
Hart-PVC schwarz
L=2000m

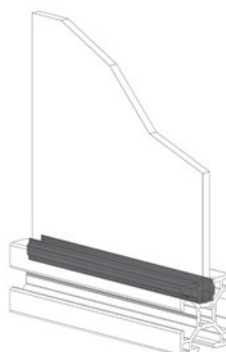
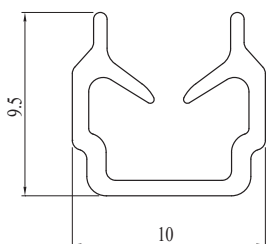



SUJUNGIAMAS SANDARIKLIS

GUARNIZIONE AD INCASTRO
JUNTA POR ENCAJE
JOINT À ENCASTREMENT
STECKDICHTUNG

Kodas	Pastaba	g/m
084.512.010	Panel thickness: 3-6 mm - Plokštės storis: 3-6 mm - Grosor de los paneles: 3-6 mm - Épaisseur panneaux: 3-6 mm - Plattendicke: 3-6 mm	45



Rigid and soft grey PVC
Kietas PVC šviesiai pilkas
L=2000mm

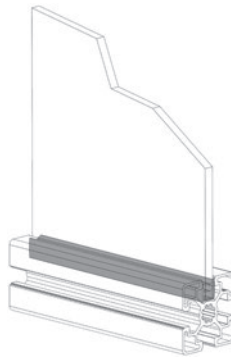
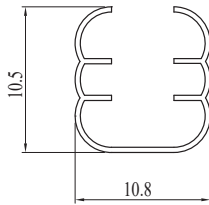



PET PILOKŠTĖS

PANNELLO IN PET
 PANEL DE PET
 PANNEAU EN PET
 PLATTE AUS PET

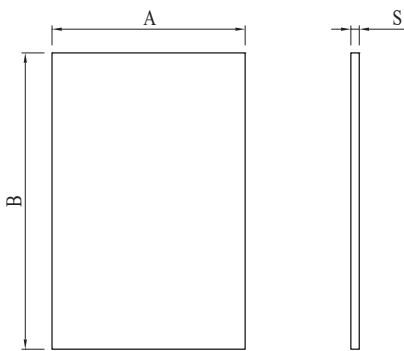

Kodas	Spalva	S	AxB	Kg/m ²
084.538.001	Skaidrus	1 mm	2050 x 3050	1,35
084.538.002	Opalo	1 mm	2050 x 3050	1,35

Shockproof and Fire classification B-s1, d0
 Atsparumas smūgiams ir ugniai B-s1, d0 klasifikacija
 Resistente a los golpes y con reacción al fuego de clase B-s1, d0
 Résistant aux chocs et résistance au feu classée B-s1, d0
 Stoßfest und in Baustoffklasse B-s1, d0 eingestuft (Brandverhalten)

POLIKARBONATO PLOKŠTĖ

PANNELLO IN POLICARBONATO
 PANEL DE POLICARBONATO
 PANNEAU EN POLYCARBONATE
 PLATTE AUS POLYCARBONAT

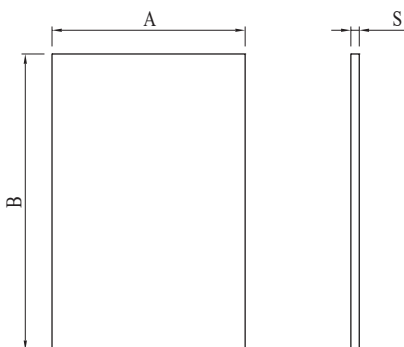

Kodas	Spalva	S	AxB	Kg/m ²
030LEX	Skaidri	3 mm	2050 x 3050	3,6
031LEX	Skaidri	4 mm	2050 x 3050	4,8
032LEX	Skaidri	5 mm	2050 x 3050	6
034LEX	Skaidri	8 mm	2050 x 3050	9,6
035LEX	Skaidri	10 mm	2050 x 3050	12

Shockproof and weather resistant (-40°C/+120°C)
 Atspari smūgiams ir oro sąlygoms (-40°C/+120°C)
 Antichoque y resistente a la intemperie (-40°C/+120°C)
 Antichoc et résistant aux intempéries (-40°C/+120°C)
 Anti-Stoß und witterungsbeständig (-40°C/+120°C)

**POLIKARBONATO PLOKŠTĖ**

PANNELLO IN POLICARBONATO
 PANEL DE POLICARBONATO
 PANNEAU EN POLYCARBONATE
 PLATTE AUS POLYCARBONAT

Kodas	Spalva	S	AxB	Kg/m ²
062LEX	Dūminė	5 mm	2050 x 3050	6

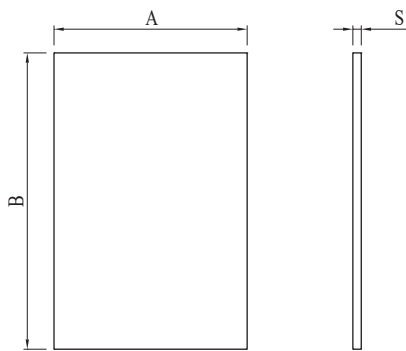

Shockproof and weather resistant (-40°C/+120°C)
 Atspari smūgiams ir oro sąlygoms (-40°C/+120°C)
 Antichoque y resistente a la intemperie (-40°C/+120°C)
 Antichoc et résistant aux intempéries (-40°C/+120°C)
 Anti-Stoß und witterungsbeständig (-40°C/+120°C)

ALUMINIO KOMPOZITINĖ PLOKŠTĖ

PANNELLO COMPOSITO IN ALLUMINIO
 PANEL COMPUESTO DE ALUMINIO ANNEAU
 COMPOSITE EN ALUMINIUM
 SANDWICH PANEEL AUS ALUMINIUM

Kodas	Spalva	S	AxB	Kg/m ²
DILITE3	Sidabrinė/Balta	3 mm	1500 x 3050	3,50

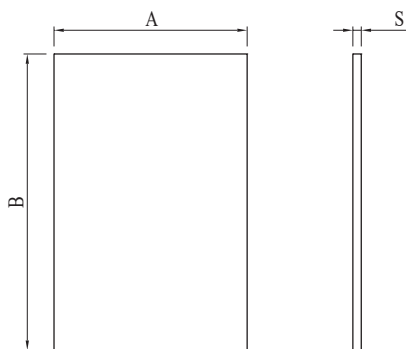

Aluminium and polythene
 Aliuminis ir polietilenas
 Aluminio y polietileno
 Aluminium et polyéthylène
 Aluminium und Polyethylen



PVC PUTŲ PLOKŠTĖS PLOKŠTĖ

PANNELLO IN PVC ES PANSO
 PANEL DE PVC EX PANDIDO
 PANNEAU EN PVC EX PANSÉ
 PLATTE AUS PVC-SCHAUM

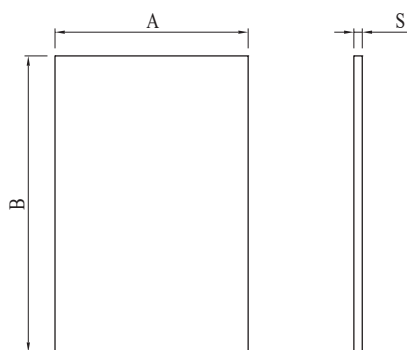

Kodas	Spalva	S	AxB	Kg/m ²
008VEKA103	Balta	3 mm	2050 x 3050	2,10
008VEKA111	Lengvai mėlyna	3 mm	2050 x 3050	2,10
008VEKA115	Juoda	3 mm	2050 x 3050	2,10

Shockproof, water- and acid-resistant, self-extinguishing
 Atsparios smūgiams, vandeniui ir rūgštims, savaime užsigesinančios
 Antichoque, resistente al agua, ácidos y autoextinguible
 Antichoc, résistant à l'eau et aux acides, auto-éteignible
 Anti-Stoß, wasserfest, säurebeständig und selbstverlöschend

LAMINUOTA PLOKŠTĖ

PANNELLO LAMITATO STRATIFICATO
 PANEL LAMINADO ESTRATIFICADO
 PANNEAU LAMINÉ STRATIFIÉ
 LAMINIERTE SCHICHTPLATTE

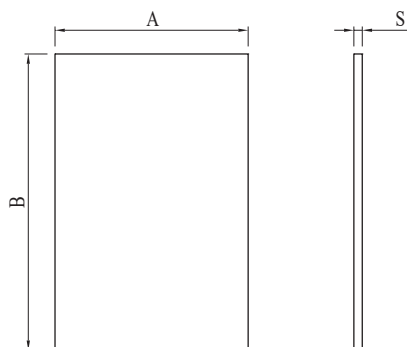

Kodas	Spalva	S	AxB	Kg/m ²
STR3MM	Balta	3 mm	1300 x 3050	4,50
STR4MM	Balta	4 mm	1300 x 3050	6
STR5MM	Balta	5 mm	1300 x 3050	7,50

Shockproof and water resistant
 Atspariosus smūgiams ir vandeniui
 Antichoque y resistente al agua
 Antichoc et résistant à l'eau
 Anti-Stoß und wasserfest



ELEKTRA SUVIRINTAS TINKLAS

RETE ELETTROSALDATA
MALLA ELECTROSOLDADA
GRILLE ÉLECTROSOUDÉE
BAUSTAHLGEWEBE

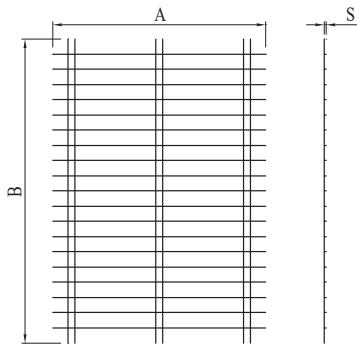
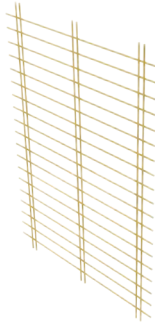

Kodas	Spalva	S	AxB	Kg/m ²
RETE 11x66	Neapdorotas	3 mm	1240 x 2400	4
RETE TEC 1003	Geltona RAL 1003	3 mm	1240 x 2400	4
RETE 11x66 INOX	AISI 304	3 mm	1240 x 2400	4

Steel, 15x105x15 (stainless steel or powder coated)
Plienas, 15x105x15 (nerūdijantis plienas arba miltelinu būdu dažytas)
Acero 15x105x15 (inoxidable o barnizado con pintura en polvo)
Acier 15x105x15 (inox ou peint à la poudre)
Stahl 15x105x15 (rostfrei oder pulverlackiert)

**ELEKTRA SUVIRINTAS
TINKLAS**

RETE ELETTROSALDATA
MALLA ELECTROSOLDADA
GRILLE ÉLECTROSOUDÉE
BAUSTAHLGEWEBE

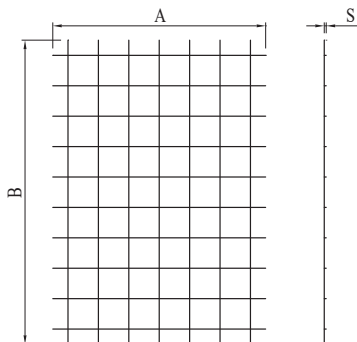
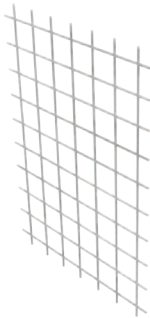

Kodas	Spalva	S	AxB	Kg/m ²
RETE 40X40X4	Neapdorotas	4 mm	1600 x 2000	4,50
670.001.000	Juodas	4 mm	2000 x 1000	4,50

40x40 steel
40x40 plienas
Acero 40x40
Acier 40x40
Stahl 40x40



ALIUMINIO VYRIS 50x50

BH
8
30

CERNIERA IN ALLUMINIO
BISAGRA DE ALUMINIO
CHARNIÈRE EN ALUMINIUM
ALUMINIUMSCHARNIER



Kodas	Pastaba	g
084.503.001	M5x20 UNI 5933 screws not included - M5x20 UNI 5933 varžtai nepridedami - Tornillos M5x20 UNI 5933, no incluidos - Vis M5x20 UNI 5933 non fournies - M5x20 UNI5933 Schrauben nicht inklusive	49

Anodised aluminium
Anodizuotas aliuminis
Aluminium anodisé
Eloxiertes Aluminium
L=6040 mm Aluminium

AISI 303 stainless-steel pin, Ø6 mm
AISI 303 nerūdijančio plieno kaištis, Ø6 mm
Perno de acero inoxidable AISI 303 Ø6
Pivot acier inox AISI 303 Ø 6
Bolzen aus rostfreiem Stahl AISI 303 Ø6

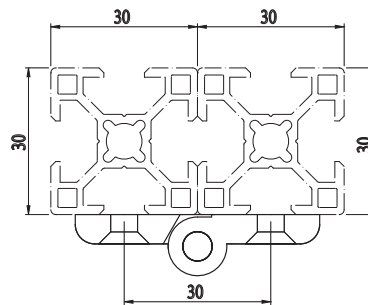
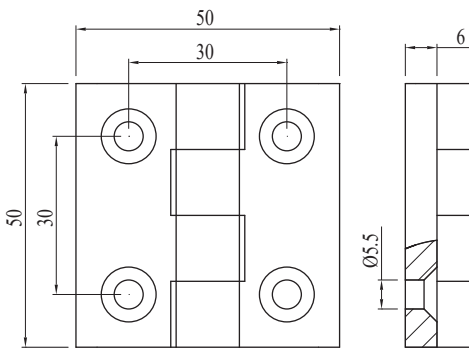

ALIUMINIO VYRIS Z 81x64

BH
10
40

CERNIERA IN ALLUMINIO
BISAGRA DE ALUMINIO
CHARNIÈRE EN ALUMINIUM
ALUMINIUMSCHARNIER



Kodas	Pastaba	g
084.502.006	M6x16 DIN 7984 screws not included - M6x16 DIN 7984 varžtai nepridedami - Tornillos M6x16 DIN 7984, no incluidos - Vis M6x16 DIN 7984 non fournies - Schrauben M6x16 DIN 7984 nicht inklusive	86

Anodised aluminium
Anodizuotas aliuminis
Aluminium anodisé
Eloxiertes Aluminium
L=6040 mm Aluminium

AISI 303 stainless-steel pin, Ø5 mm
AISI 303 nerūdijančio plieno kaištis, Ø5
Perno de acero inoxidable AISI 303 Ø5
Pivot acier inox AISI 303 Ø 5
Bolzen aus rostfreiem Stahl AISI 303 Ø5

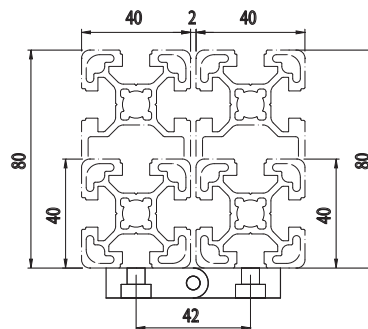
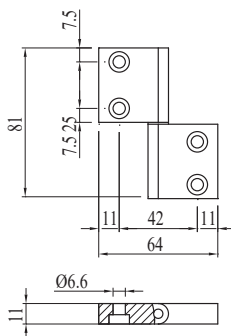



ALUMINIO VYRIS Z 81x62



CERNIERA IN ALLUMINIO
BISAGRA DE ALUMINIO
CHARNIÈRE EN ALUMINIUM
ALUMINIUMSCHARNIER



Kodas	Pastaba	g
084.502.003	Screws M6x16 DIN 7984 not included - M6X16 DIN7984 varžtai neįeina - Tornillos M6x16 DIN 7984 no incluidos - Vis M6x16 DIN 7984 non fournies - Schrauben M6x16 DIN 7984 nicht inklusive	86

Anodised aluminium
Anodizuotas aliuminis
Aluminium anodisé
Eloxiertes Aluminium
L=6040 mm Aluminium

AISI 303 stainless-steel pin, Ø5 mm
AISI nerūdijančio plieno kaištis 303 Ø5
Perno de acero inoxidable AISI 303 Ø5
Pivot acier inox AISI 303 Ø 5
Bolzen aus rostfreiem Stahl AISI 303 Ø5

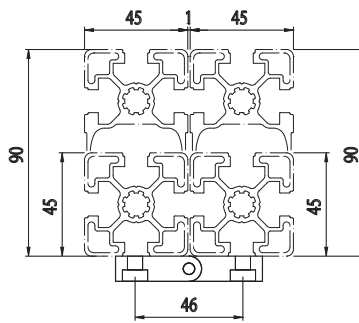
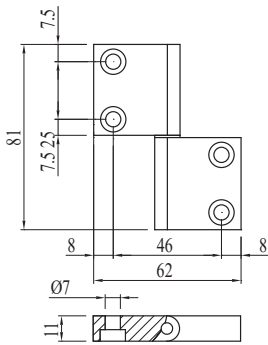

ALUMINIO VYRIS Z 81x79



CERNIERA IN ALLUMINIO
BISAGRA DE ALUMINIO
CHARNIÈRE EN ALUMINIUM
ALUMINIUMSCHARNIER



Kodas	Pastaba	g
084.502.005	Screws M6x16 DIN 7984 not included - M6X16 DIN7984 varžtai neįeina - Tornillos M6x16 DIN 7984 no incluidos - Vis M6x16 DIN 7984 non fournies - Schrauben M6x16 DIN 7984 nicht inklusive	86

Anodised aluminium
Anodizuotas aliuminis
Aluminium anodisé
Eloxiertes Aluminium
L=6040 mm

AISI 303 stainless-steel pin, Ø5 mm
AISI nerūdijančio plieno kaištis 303 Ø5
Perno de acero inoxidable AISI 303 Ø5
Pivot acier inox AISI 303 Ø 5
Bolzen aus rostfreiem Stahl AISI 303 Ø5

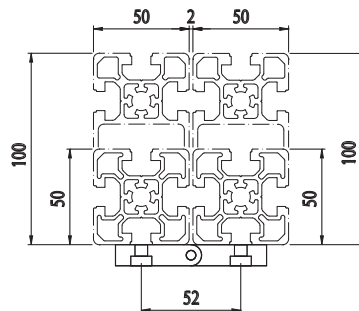
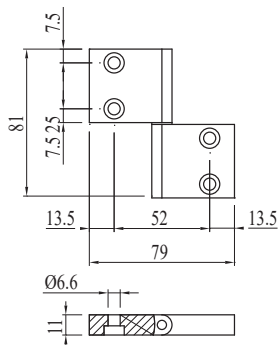



ALUMINIO VYRIS

CERNIERA IN ALLUMINIO
BISAGRA DE ALUMINIO
CHARNIÈRE EN ALUMINIUM
ALUMINIUMSCHARNIER



Kodas	Pastaba	g
084.503.002	M5x20 DIN 7984 screws not included -Varžtai M5x20 DIN 7984 neieina - Tornillos M5x20 DIN 7984 no incluidos - Vis M5x20 DIN 7984 non fournies - Schrauben M5x20 DIN 7984 nicht inklusive	75

Anodised aluminium
Anodizuotas aliuminis
Aluminium anodisé
Eloxiertes Aluminium
L=6040 mm Aluminium

AISI 303 stainless-steel pin, Ø8 mm
AISI nerūdijančio plieno kaištis 303 Ø8
Perno de acero inoxidable AISI 303 Ø8
Pivot acier inox AISI 303 Ø 8
Bolzen aus rostfreiem Stahl AISI 303 Ø8

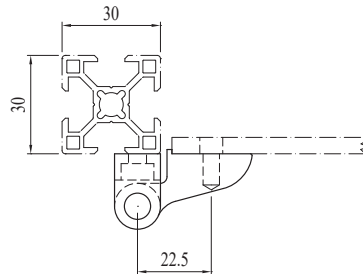
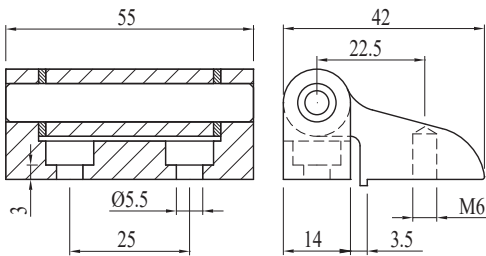

ALUMINIO VYRIS

CERNIERA IN ALLUMINIO
BISAGRA DE ALUMINIO
CHARNIÈRE EN ALUMINIUM
ALUMINIUMSCHARNIER



Kodas	Pastaba	g
084.503.003	M5x20 UNI 5933 screws not included -Varžtai M5x20 UNI 5933 neieina - Tornillos M5x20 UNI 5933 no incluidos - Vis M5x20 UNI 5933 non fournies - Schrauben M5x20 UNI 5933 nicht inklusive	85

Anodised aluminium
Anodizuotas aliuminis
Aluminium anodisé
Eloxiertes Aluminium
L=6040 mm Aluminium

AISI 303 stainless-steel pin, Ø8 mm
AISI nerūdijančio plieno kaištis 303 Ø8
Perno de acero inoxidable AISI 303 Ø8
Pivot acier inox AISI 303 Ø 8
Bolzen aus rostfreiem Stahl AISI 303 Ø8

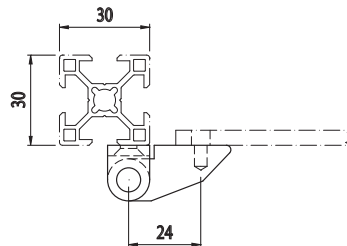
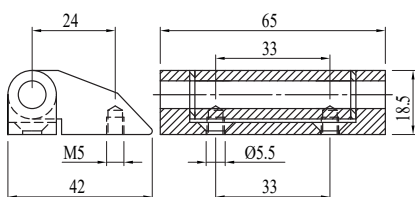



ALUMINIO VYRIS Z 81x81



CERNIERA IN ALLUMINIO
BISAGRA DE ALUMINIO
CHARNIÈRE EN ALUMINIUM
ALUMINIUMSCHARNIER

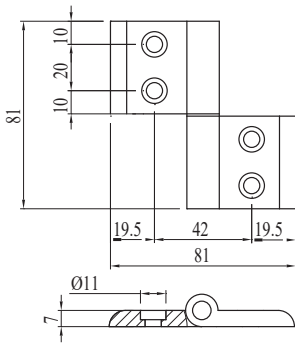

Kodas	Pastaba	g
084.500.016	M6x16 DIN 7984 screws not included - M6X16 DIN7984 varžtai neįeina - Tornillos M6x16 DIN 7984 no incluidos - Vis M6x16 DIN 7984 non fournies - Schrauben M6x16 DIN 7984 nicht inklusive	100

Anodised aluminium
Anodizuotas aliuminis
Aluminium anodisé
Eloxiertes Aluminium
L=6040 mm Aluminium

AISI 303 stainless-steel pin, Ø8 mm
AISI nerūdijančio plieno kaištis 303 Ø8
Perno de acero inoxidable AISI 303 Ø8
Pivot acier inox AISI 303 Ø 8
Bolzen aus rostfreiem Stahl AISI 303 Ø8

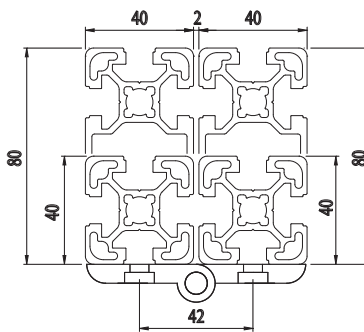

ALUMINIO VYRIS Z 81x80



CERNIERA IN ALLUMINIO
BISAGRA DE ALUMINIO
CHARNIÈRE EN ALUMINIUM
ALUMINIUMSCHARNIER

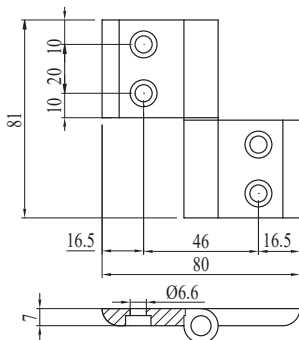

Kodas	Pastaba	g
084.500.003	M6x16 DIN 7984 screws not included -Varžtai DIN M6x16 neįeina - Tornillos M6x16 DIN 7984 no incluidos - Vis M6x16 DIN 7984 non fournies - Schrauben M6x16 DIN 7984 nicht inklusive	99

Anodised aluminium
Anodizuotas aliuminis
Aluminium anodisé
Eloxiertes Aluminium
L=6040 mm Aluminium

AISI 303 stainless-steel pin, Ø8 mm
AISI nerūdijančio plieno kaištis 303 Ø8
Perno de acero inoxidable AISI 303 Ø8
Pivot acier inox AISI 303 Ø 8
Bolzen aus rostfreiem Stahl AISI 303 Ø8

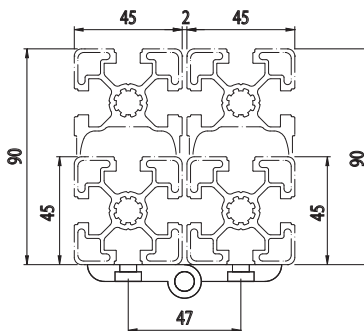

**ALIUMINIO VYRIS Z81x 80**BH
10
50

CERNIERA IN ALLUMINIO BISAGRA
DE ALUMINIO CHARNIÈRE EN
ALUMINIUM
ALUMINIUMSCHARNIER

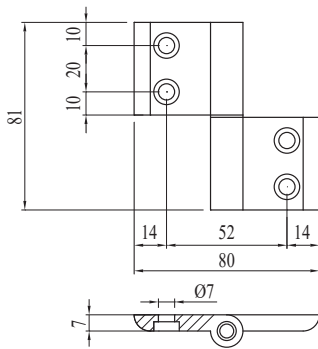

Kodas	Pastaba	g
084.500.015	M6x16 DIN 7984 screws not included - M6X16 DIN7984 varžtai neįeina - Tornillos M6x16 DIN 7984, no incluidos - Vis M6x16 DIN 7984 non fournies - Schrauben M6x16 DIN 7984 nicht inklusive	100

Anodised aluminium
Anodizuotas aliuminis
Aluminium anodisé
Eloxiertes Aluminium
L=6040 mm
Eloxiertes Aluminium

AISI 303 stainless-steel pin, Ø8 mm
AISI nerūdijančio plieno kaištis 303 Ø8
Perno de acero inoxidable AISI 303 Ø8
Pivot acier inox AISI 303 Ø 8
Bolzen aus rostfreiem Stahl AISI 303 Ø8

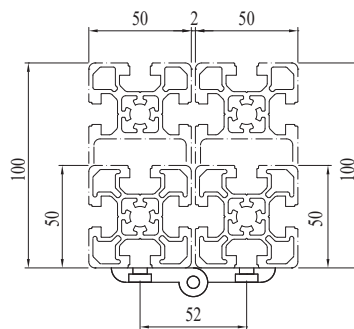
**ALIUMINIO VYRIS 100x81**BH
10
40

CERNIERA IN ALLUMINIO
BISAGRA DE ALUMINIO
CHARNIÈRE EN ALUMINIUM
ALUMINIUMSCHARNIER

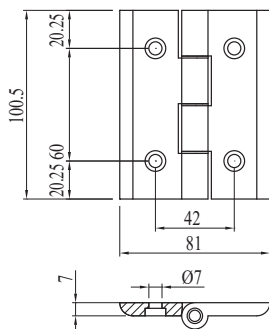

Kodas	Pastaba	g
084.500.018	M6x16 DIN 7984 screws not included - M6X16 DIN7984 varžtai neįeina - Tornillos M6x16 DIN 7984 no incluidos - Vis M6x16 DIN 7984 non fournies - Schrauben M6x16 DIN 7984 nicht inklusive	183

Anodised aluminium
Anodizuotas aliuminis
Aluminium anodisé
Eloxiertes Aluminium
L=6040 mm
Eloxiertes Aluminium

AISI 303 stainless-steel pin, Ø8 mm
AISI nerūdijančio plieno kaištis 303 Ø8
Perno de acero inoxidable AISI 303 Ø8
Pivot acier inox AISI 303 Ø 8
Bolzen aus rostfreiem Stahl AISI 303 Ø8

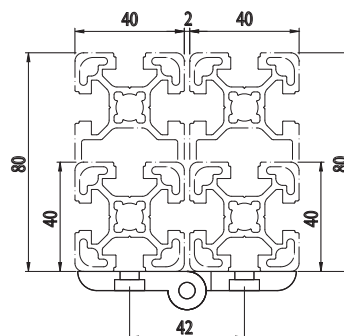



ALUMINIO VYRIS 100x80



CERNIERA IN ALLUMINIO
BISAGRA DE ALUMINIO
CHARNIÈRE EN ALUMINIUM
ALUMINIUMSCHARNIER



Kodas	Pastaba	g
084.500.006	M6x16 DIN 7984 screws not included - M6X16 DIN7984 varžtai neįeina - Tornillos M6x16 DIN 7984 no incluidos - Vis M6x16 DIN 7984 non fournies - Schrauben M6x16 DIN 7984 nicht inklusive	180

Anodised aluminium
Anodizuotas aliuminis
Aluminium anodisé
Eloxiertes Aluminium
L=6040 mm Aluminium

AISI 303 stainless-steel pin, Ø8 mm
AISI nerūdijančio plieno kaištis 303 Ø8
Perno de acero inoxidable AISI 303 Ø8
Pivot acier inox AISI 303 Ø 8
Bolzen aus rostfreiem Stahl AISI 303 Ø8

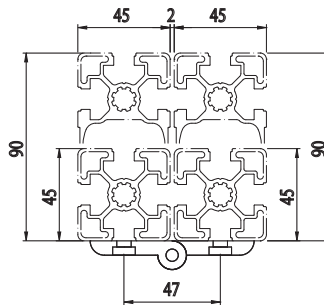
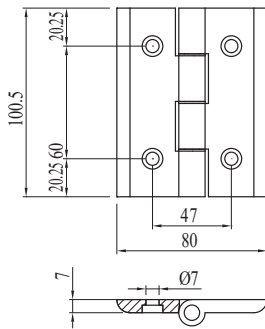

ALUMINIO VYRIS 100x80



CERNIERA IN ALLUMINIO
BISAGRA DE ALUMINIO
CHARNIÈRE EN ALUMINIUM
ALUMINIUMSCHARNIER



Kodas	Pastaba	g
084.500.017	M6x16 DIN 7984 screws not included - M6X16 DIN7984 varžtai neįeina - Tornillos M6x16 DIN 7984, no incluidos - Vis M6x16 DIN 7984 non fournies - Schrauben M6x16 DIN 7984 nicht inklusive	183

Anodised aluminium
Anodizuotas aliuminis
Aluminium anodisé
Eloxiertes Aluminium
L=6040 mm Aluminium

AISI 303 stainless-steel pin, Ø8 mm
AISI nerūdijančio plieno kaištis 303 Ø8
Perno de acero inoxidable AISI 303 Ø8
Pivot acier inox AISI 303 Ø 8
Bolzen aus rostfreiem Stahl AISI 303 Ø8

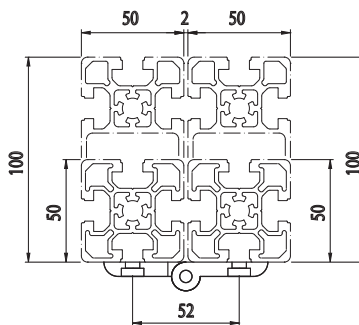
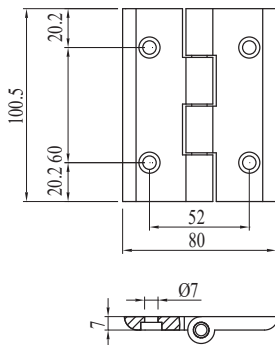

**ALIUMINIO VYRIS 60x38**

CERNIERA IN ALLUMINIO
BISAGRA DE ALUMINIO
CHARNIÈRE EN ALUMINIUM
ALUMINIUMSCHARNIER

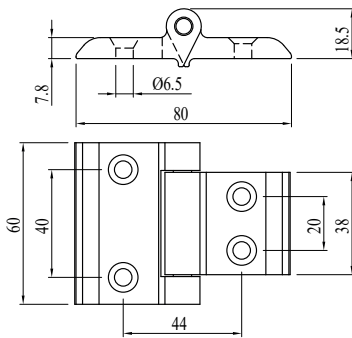

Kodas	Pastaba	g
084.500.023	M6x20 DIN 7984 screws not included - Varžtai M6x20 DIN 7984 neieina - Tornillos M6x20 DIN 7984 no incluidos - Vis M6x20 DIN 7984 non fournies - Schrauben M6x20 DIN 7984 nicht inklusive	102,5

Anodised aluminium
Anodizuotas aliuminis
Aluminium anodisé
Eloxiertes Aluminium
L=6040 mm Aluminium

AISI 303 stainless-steel pin, Ø8 mm
AISI nerūdijančio plieno kaištis 303 Ø8
Perno de acero inoxidable AISI 303 Ø8
Pivot acier inox AISI 303 Ø 8
Bolzen aus rostfreiem Stahl AISI 303 Ø8

ALIUMINIO VYRIS 76x113

CERNIERA IN ALLUMINIO
BISAGRA DE ALUMINIO
CHARNIÈRE EN ALUMINIUM
ALUMINIUMSCHARNIER

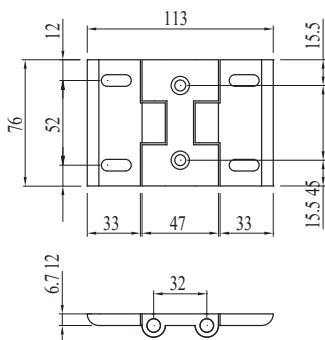

Kodas	Pastaba	g
084.500.009	M6x16 DIN 7984 screws not included - M6X16 DIN7984 varžtai neieina - Tornillos M6x16 DIN 7984 no incluidos - Vis M6x16 DIN 7984 non fournies - Schrauben M6x16 DIN 7984 nicht inklusive	152

Anodised aluminium
Anodizuotas aliuminis
Aluminium anodisé
Eloxiertes Aluminium
L=6040 mm Aluminium

AISI 303 stainless-steel pin, Ø8 mm
AISI nerūdijančio plieno kaištis 303 Ø8
Perno de acero inoxidable AISI 303 Ø8
Pivot acier inox AISI 303 Ø 8
Bolzen aus rostfreiem Stahl AISI 303 Ø8

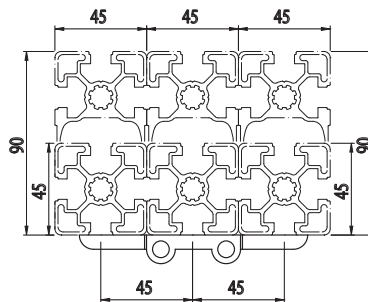



ALUMINIO VYRIS Lx52

CERNIERA IN ALLUMINIO
BISAGRA DE ALUMINIO
CHARNIÈRE EN ALUMINIUM
ALUMINIUMSCHARNIER



Kodas	Pastaba	ms
084.500.020	M6x20 DIN 7984 screws not included - Varžtai M6x20 DIN 7984 neieina - Tornillos M6x20 DIN 7984 no incluidos - Vis M6x20 DIN 7984 non fournies - Schrauben M6x20 DIN 7984 nicht inklusive	1,80

Anodised aluminium
Anodizuotas aliuminis
Aluminium anodisé
Eloxiertes Aluminium
L=6040 mm Aluminium

Medž.eriale inglese
Medž.eriale italiano
Medž.eriale spagnolo
Medž.eriale francese
Medž.eriale tedesco

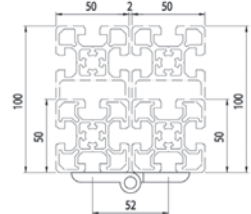
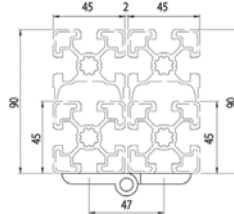
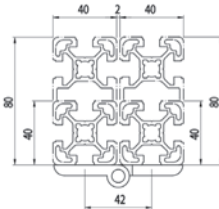
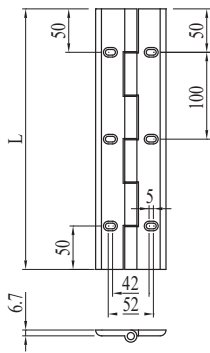

KODAS FOR ORDER
UŽSAKYMO KODAS / CÓDIGO PARA
PEDIR KODAS POUR ORDRE / TEIL NR. ZUR

084.500.020.

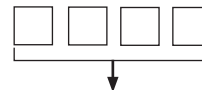

L external hinge length (multiple sizes of 100m, min. 200/max 3000mm)
L išorinio vyrio ilgis (įvairūs dydžiai 100mm, min 200/ max 3000mm)
L longitud externa de la bisagra (medidas múltiples de 100mm, min 200/ max 3000mm)
L longueur extérieure de la charnière (mesures multiples de 100mm, min 200/ max 3000mm)
L äußere Länge der Scharniere (vielfach von 100mm, min 200/ max 3000mm)

**ALUMINIO VYRIS 81x45**

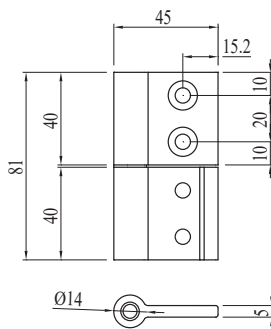

CERNIERA IN ALLUMINIO
BISAGRA DE ALUMINIO
CHARNIÈRE EN ALUMINIUM
ALUMINIUMSCHARNIER



Kodas	Pastaba	g
084.500.012	M6x12 UNI 5933 screws not included -Varžtai M6x12 UNI 5933 neieina - Tornillos M6x12 UNI 5933 no incluidos - Vis M6x12 UNI 5933 non fournies - Schrauben M6x12 UNI 5933 nicht inklusive	85

Anodised aluminium
Anodizuotas aliuminis
Aluminium anodisé
Eloxiertes Aluminium
L=6040 mm Aluminium

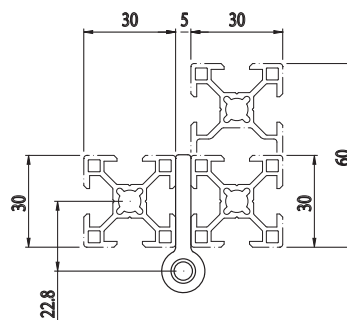
AISI 303 stainless-steel pin, Ø8 mm
AISI nerūdijančio plieno kaištis 303 Ø8
Perno de acero inoxidable AISI 303 Ø8
Pivot acier inox AISI 303 Ø 8
Bolzen aus rostfreiem Stahl AISI 303 Ø8

**ALUMINIO VYRIS 81x45**

CERNIERA IN ALLUMINIO
BISAGRA DE ALUMINIO
CHARNIÈRE EN ALUMINIUM
ALUMINIUMSCHARNIER

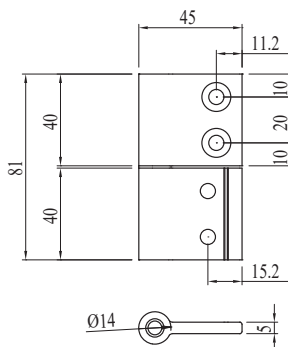

Kodas	Pastaba	g
084.500.021	M6x12 and M6x16 UNI 5933 screws not included -Varžtai M6x12 ir M6x16 UNI 5933 neieina - Tornillos M6x12 e M6x16 UNI 5933 no incluidos - Vis M6x12 e M6x16 UNI 5933 non fournies - Schrauben M6x12 e M6x16 UNI 5933 nicht inklusive	85

Anodised aluminium
Anodizuotas aliuminis
Aluminium anodisé
Eloxiertes Aluminium
L=6040 mm Aluminium

AISI 303 stainless-steel pin, Ø8 mm
AISI nerūdijančio plieno kaištis 303 Ø8
Perno de acero inoxidable AISI 303 Ø8
Pivot acier inox AISI 303 Ø 8
Bolzen aus rostfreiem Stahl AISI 303 Ø8

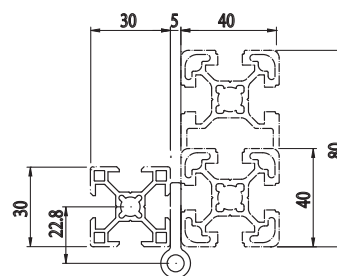



ALUMINIO VYRIS 81x45

CERNIERA IN ALLUMINIO
BISAGRA DE ALUMINIO
CHARNIÈRE EN ALUMINIUM
ALUMINIUMSCHARNIER

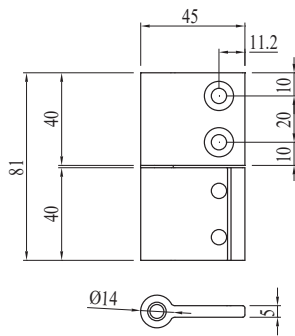

Kodas	Pastaba	g
084.500.011	M6x16 UNI 5933 screws not included -Varžtai M6x16 UNI 5933 neieina - Tornillos M6x16 UNI 5933 no incluidos - Vis M6x16 UNI 5933 non fournies - Schrauben M6x16 UNI 5933 nicht inklusive	85

Anodised aluminium
Anodizuotas aliuminis
Aluminium anodisé
Eloxiertes Aluminium
L=6040 mm Aluminium

AISI 303 stainless-steel pin, Ø8 mm
AISI nerūdijančio plieno kaištis 303 Ø8
Perno de acero inoxidable AISI 303 Ø8
Pivot acier inox AISI 303 Ø 8
Bolzen aus rostfreiem Stahl AISI 303 Ø8

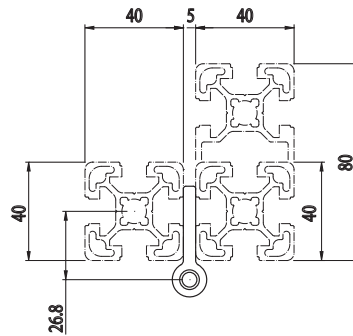

ALUMINIO VYRIS 81x45

CERNIERA IN ALLUMINIO
BISAGRA DE ALUMINIO
CHARNIÈRE EN ALUMINIUM
ALUMINIUMSCHARNIER

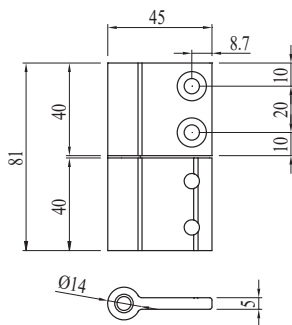

Kodas	Pastaba	g
084.500.010	M6x20 UNI 5933 screws not included -Varžtai M6x20 UNI 5933 neieina - Tornillos M6x20 UNI 5933 no incluidos - Vis M6x20 UNI 5933 non fournies - Schrauben M6x20 UNI 5933 nicht inklusive	85

Anodised aluminium
Anodizuotas aliuminis
Aluminium anodisé
Eloxiertes Aluminium
L=6040 mm Aluminium

AISI 303 stainless-steel pin, Ø8 mm
AISI nerūdijančio plieno kaištis 303 Ø8
Perno de acero inoxidable AISI 303 Ø8
Pivot acier inox AISI 303 Ø 8
Bolzen aus rostfreiem Stahl AISI 303 Ø8

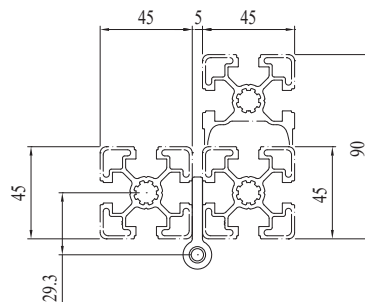

**ZAMAK VYRIS 40x39**

CERNIERA IN ZAMA
BISAGRA DE ZAMAK
CHARNIÈRE EN ZAMAK
ZAMAKSCHARNIER

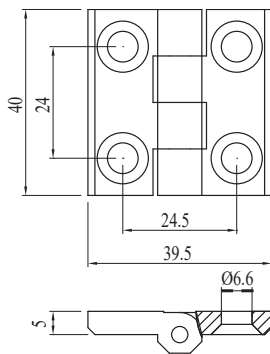

Kodas	Pastaba	g
084.501.020	M6x8 UNI 5933 screws not included - Varžtai M6x8 UNI 5933 neieina - Tornillos M6x8 UNI 5933 no incluidos - Vis M6x8 UNI 5933 non fournies - Schrauben M6x8 UNI 5933 nicht inklusive	120

Black painted zamak
Zamak dažytas juodai
Zamak barnizado negro
Zamak peint noir
Schwarz lackierte Zamak-Legierung

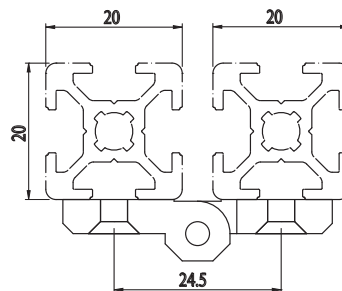
**ZAMAK VYRIS 50x48**

CERNIERA IN ZAMA
BISAGRA DE ZAMAK
CHARNIÈRE EN ZAMAK
ZAMAKSCHARNIER

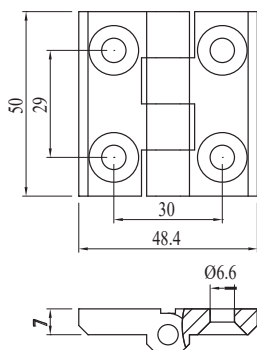

Kodas	Pastaba	g
084.501.019	M6x16 UNI 5933 screws not included - Varžtai M6x16 UNI 5933 neieina - Tornillos M6x16 UNI 5933 no incluidos - Vis M6x16 UNI 5933 non fournies - Schrauben M6x16 UNI 5933 nicht inklusive	120

Black painted zamak
Zamak dažytas juodai
Zamak barnizado negro
Zamak peint noir
Schwarz lackierte Zamak-Legierung

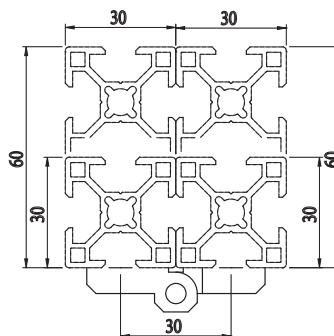



ZAMAK VYRIS 40x27
CERNIERA IN ZAMAK
BISAGRA DE ZAMAK
CHARNIÈRE EN ZAMAK
ZAMAKSCHARNIER



Kodas	Pastaba	g
084.501.017	M8x16 DIN 7984 screws -Varžtai M8x16 DIN 7984 neieina - Tornillos M8x16 DIN 7984 no incluidos - Vis M8x16 DIN 7984 non fournies - Schrau ben M8x16 DIN 7984 nicht inklusive	215

Black painted zamak
Zamak dažytas juodai
Zamak barnizado negro
Zamak peint noir
Schwarz lackierte Zamak-Legierung

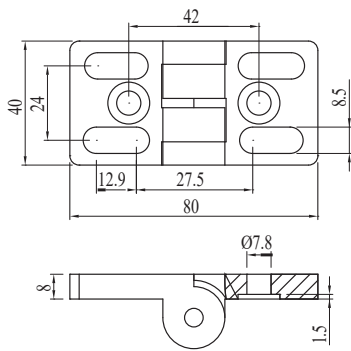

**POLIAMIDO VYRIS 30x39**BH
6
20

CERNIERA IN POLIAMMIDE
BISAGRA DE POLIAMIDA
CHARNIÈRE EN POLYAMIDE
POLYAMIDSCHARNIER

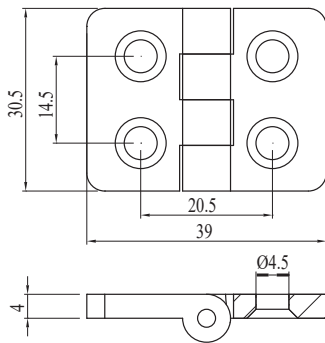

Kodas	Pastaba	g
084.501.011	M4x8 UNI 5933 screws not included - Varžtai M4x8 UNI 5933 neieina - Tornillos M4x8 UNI 5933 no incluidos - Vis M4x8 UNI 5933 non fournies - Schrauben M4x8 UNI 5933 nicht inklusive	13

Black polyamide
Juodas poliamidas
Poliamida color negro
Polyamide noir
Schwarzes Polyamid

AISI 303 stainless-steel pin, Ø5 mm
AISI nerūdijančio plieno kaištis 303 Ø5
Perno de acero inoxidable AISI 303 Ø5
Pivot acier inox AISI 303 Ø 5
Bolzen aus rostfreiem Stahl AISI 303 Ø5

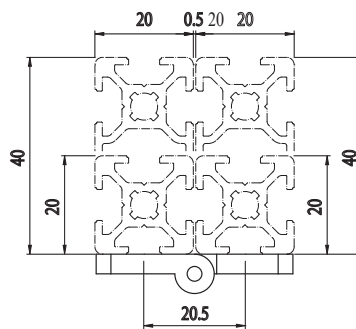
**POLIAMIDO VYRIS 50x30**BH
8
30

CERNIERA IN POLIAMMIDE
BISAGRA DE POLIAMIDA
CHARNIÈRE EN POLYAMIDE
POLYAMIDSCHARNIER

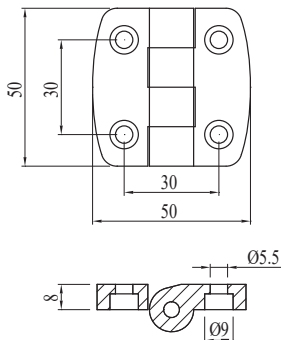

Kodas	Pastaba	g
084.501.008	M5x16 DIN 7984 screws not included - Varžtai M5x16 DIN 7984 neieina - Tornillos M5x16 DIN 7984 no incluidos - Vis M5x16 DIN 7984 non fournies - Schrauben M5x16 DIN 7984 nicht inklusive	32

Black polyamide
Juodas poliamidas
Poliamida color negro
Polyamide noir
Schwarzes Polyamid

AISI 303 stainless-steel pin, Ø5 mm
AISI nerūdijančio plieno kaištis 303 Ø5
Perno de acero inoxidable AISI 303 Ø5
Pivot acier inox AISI 303 Ø 5
Bolzen aus rostfreiem Stahl AISI 303 Ø5

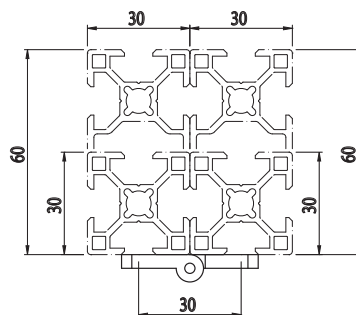



POLIAMIDO VYRIS 45x53

CERNIERA IN POLIAMMIDE
BISAGRA DE POLIAMIDA
CHARNIÈRE EN POLYAMIDE
POLYAMIDSCHARNIER

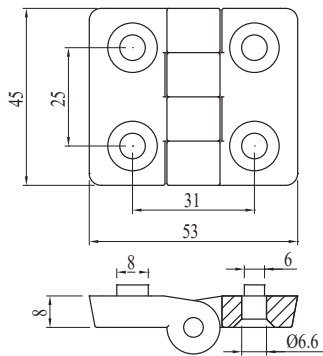

Kodas	Pastaba	g
084.501.013	M6x16 UNI 5933 screws not included -Varžtai M6x16 UNI 5933 neieina - Tornillos M6x16 UNI 5933 no incluidos - Vis M6x16 UNI 5933 non fournies - Schrauben M6x16 UNI 5933 nicht inklusive	26

Black polyamide
Juodas poliamidas
Poliamida color negro
Polyamide noir
Schwarzes Polyamid

AISI 303 stainless-steel pin, Ø5 mm
AISI nerūdijančio plieno kaištis 303 Ø5
Perno de acero inoxidable AISI 303 Ø5
Pivot acier inox AISI 303 Ø 5
Bolzen aus rostfreiem Stahl AISI 303 Ø5

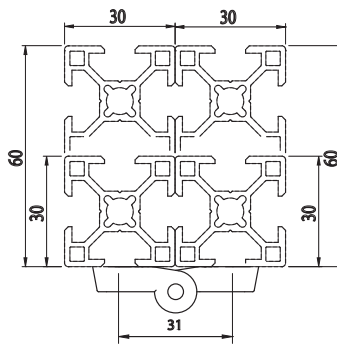

POLIAMIDO VYRIS 44x53

CERNIERA IN POLIAMMIDE
BISAGRA DE POLIAMIDA
CHARNIÈRE EN POLYAMIDE
POLYAMIDSCHARNIER

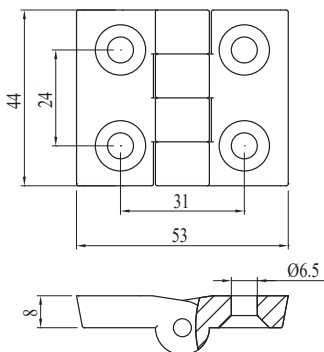

Kodas	Pastaba	g
084.501.021	M6x16 UNI 5933 screws not included -Varžtai M6x16 UNI 5933 neieina - Tornillos M6x16 UNI 5933 no incluidos - Vis M6x16 UNI 5933 non fournies - Schrauben M6x16 UNI 5933 nicht inklusive	29

Black polyamide
Juodas poliamidas
Poliamida color negro
Polyamide noir
Schwarzes Polyamid

AISI 303 stainless-steel pin, Ø5 mm
AISI nerūdijančio plieno kaištis 303 Ø5
Perno de acero inoxidable AISI 303 Ø5
Pivot acier inox AISI 303 Ø 5
Bolzen aus rostfreiem Stahl AISI 303 Ø5

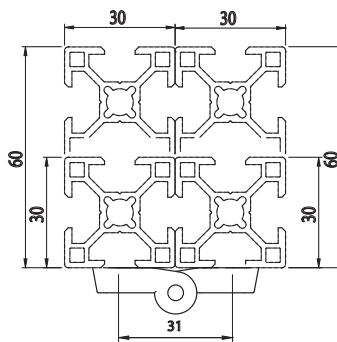

**POLIAMIDO VYRIS 50x70**BH
10
40

CERNIERA IN POLIAMMIDE
BISAGRA DE POLIAMIDA
CHARNIÈRE EN POLYAMIDE
POLYAMIDSCHARNIER



Kodas	Pastaba	g
084.501.009	M6x12 DIN 7984 screws not included -Varžtai DIN M6x12 DIN 7984 neieina - Tornillos M6x12 DIN 7984 no incluidos - Vis M6x12 DIN 7984 non fournies - Schrauben M6x12 DIN 7984 nicht inklusive	40

Black polyamide
Juodas poliamidas
Poliamida color negro
Polyamide noir
Schwarzes Polyamid

AISI 303 stainless-steel pin, Ø5 mm
AISI nerūdijančio plieno kaištis 303 Ø5
Perno de acero inoxidable AISI 303 Ø5
Pivot acier inox AISI 303 Ø 5
Bolzen aus rostfreiem Stahl AISI 303 Ø5

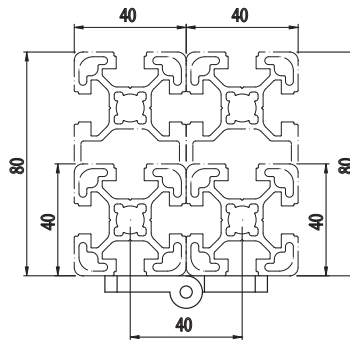
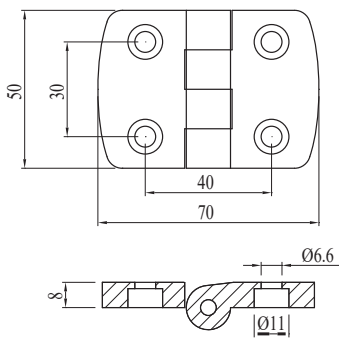
**POLIAMIDO VYRIS 50x62**

CERNIERA IN POLIAMMIDE
BISAGRA DE POLIAMIDA
CHARNIÈRE EN POLYAMIDE
POLYAMIDSCHARNIER



Kodas	Pastaba	g
084.501.014	M8x12 DIN 7984 screws not included -Varžtai M8x12 DIN 7984 neieina - Tornillos M8x12 DIN 7984 no incluidos - Vis M8x12 DIN 7984 non fournies - Schrauben M8x12 DIN 7984 nicht inklusive	37

Black polyamide
Juodas poliamidas
Poliamida color negro
Polyamide noir
Schwarzes Polyamid

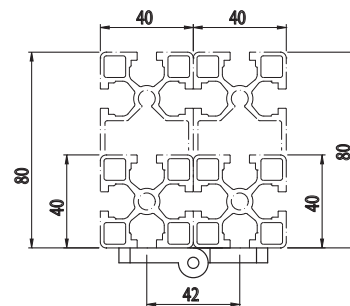
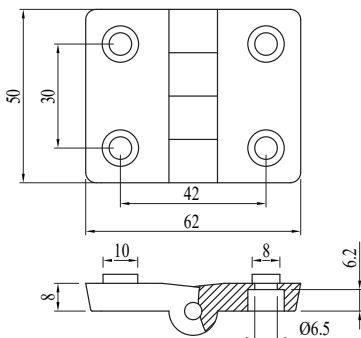



POLIAMIDO VYRIS 50x70



CERNIERA IN POLIAMMIDE
BISAGRA DE POLIAMIDA
CHARNIÈRE EN POLYAMIDE
POLYAMIDSCHARNIER



Kodas	Pastaba	g
084.501.010	M8x16 DIN 7984 screws not included -Varžtai M8x16 DIN 7984 neieina - Tornillos M8x16 DIN 7984 no incluidos - Vis M8x16 DIN 7984 non fournies - Schrauben M8x16 DIN 7984 nicht inklusive	39

Black polyamide
Juodas poliamidas
Poliamida color negro
Polyamide noir
Schwarzes Polyamid

AISI 303 stainless-steel pin, Ø5 mm
AISI nerūdijančio plieno kaištis 303 Ø5
Perno de acero inoxidable AISI 303 Ø5
Pivot acier inox AISI 303 Ø 5
Bolzen aus rostfreiem Stahl AISI 303 Ø5

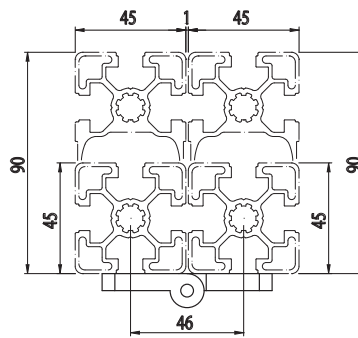
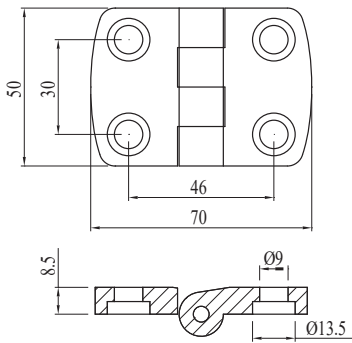

POLIAMIDO VYRIS 50x70

CERNIERA IN POLIAMMIDE
BISAGRA DE POLIAMIDA
CHARNIÈRE EN POLYAMIDE
POLYAMIDSCHARNIER



Kodas	Pastaba	g
084.501.015	Screws M8x20 UNI 5933 not included -Varžtai M8x20 UNI 5933 neieina - Tornillos M8x20 UNI 5933 no incluidos - Vis M8x20 UNI 5933 non fournies - Schrauben M8x20 UNI 5933 nicht inklusive	44

Black polyamide
Juodas poliamidas
Poliamida color negro
Polyamide noir
Schwarzes Polyamid

AISI 303 stainless-steel pin, Ø5 mm
AISI nerūdijančio plieno kaištis 303 Ø5
Perno de acero inoxidable AISI 303 Ø5
Pivot acier inox AISI 303 Ø 5
Bolzen aus rostfreiem Stahl AISI 303 Ø5

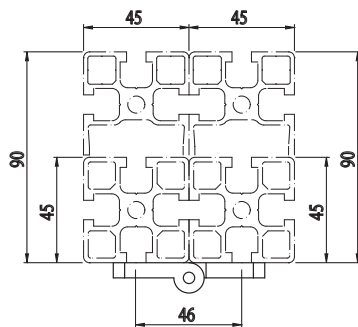
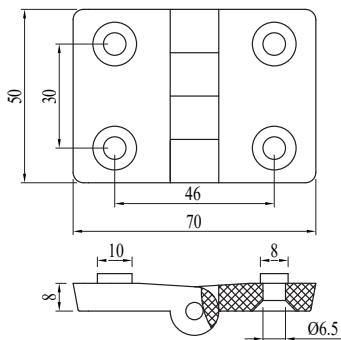

**POLIAMIDO VYRIS 40x73**

CERNIERA IN POLIAMMIDE
BISAGRA DE POLIAMIDA
CHARNIÈRE EN POLYAMIDE
POLYAMIDSCHARNIER

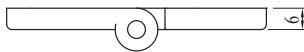
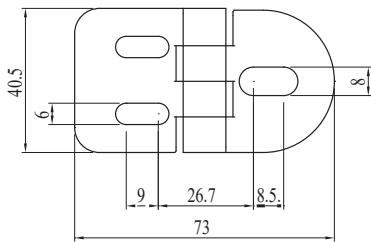

Kodas	Pastaba	g
084.501.016	M5 and M8 DIN 7984 screws not included -Varžtai M5 e M8 DIN 7984 neieina - Tornillos M5 y M8 DIN 7984 no incluidos - Vis M5 et M8 DIN 7984 non fournies - Schrauben M5 und M8 DIN 7984 nicht inklusive	25

Black polyamide
Juodas poliamidas
Poliamida color negro
Polyamide noir
Schwarzes Polyamid

AISI 303 stainless-steel pin, Ø5 mm
AISI nerūdijančio plieno kaištis 303 Ø5
Perno de acero inoxidable AISI 303 Ø5
Pivot acier inox AISI 303 Ø 5
Bolzen aus rostfreiem Stahl AISI 303 Ø5



RANKENA

MANIGLIA
ASIDERO
POIGNÉE
GRIFF

Kodas	Pastaba	d	A	D	B	s	g
084.504.001	-	6,50	108	38	93	21	26
084.504.002 -		9	129	44	112,5	28	34
084.504.003	-	9	146	44	128,50	28,5	37



Black polyamide
Juodas poliamidas
Poliamida color negro
Polyamide noir
Schwarzes Polyamid

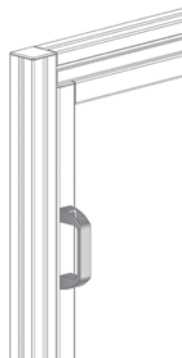
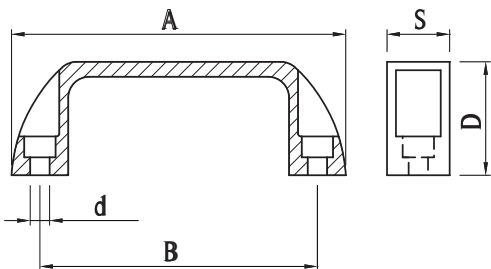

RANKENA 43x138

MANIGLIA ASIDERO POIGNÉE
GRIFF

Kodas	Pastaba	g
013.506.009	Inclined handle -Arkinė rankena - Asidero inclinado - Poignée inclinée - Geneigter Griff	42,6



PA6+GF, RAL 7023

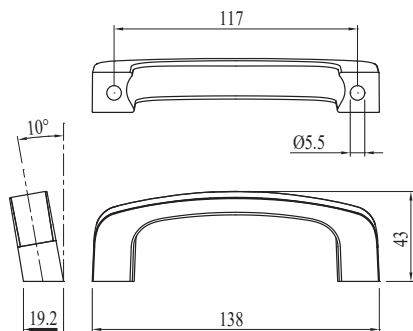

Dangtelis - Cap - Tapon - Embout - Abdeckkappe			
Kodas	Medž.	g	Sp.
013.506.010A	PA6GF	10	C
013.506.010G	PA6GF	10	B

**RANKENA 43x138**MANIGLIA ASIDERO
POIGNÉE GRIFF

Kodas	Pastaba	g
013.506.008	Inclined handle - Arkinė rankena - Asidero inclinado - Poignée inclinée - Geneigter Griff	47,1

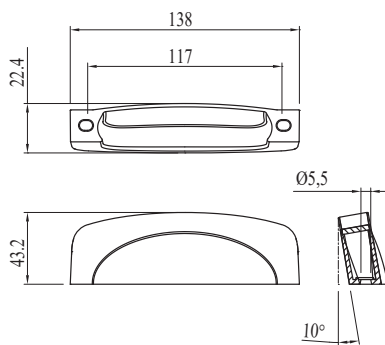
**PA6+GF, RAL 7023**

Dangtelis - Cap - Tapon - Embout - Abdeckkappe			
Kodas	Medž.	g	Sp.
013.506.010A	PA6GF	10	C
013.506.010G	PA6GF	10	B

**D FORMOS RANKENA SU ATRAMOMIS**

MANIGLIA ASIDERO POIGNÉE GRIFF

Kodas	Pastaba	g
084.506.011	D-handle with orange inserts - D formos rankena su oranžiniais įdėklais - Asidero en forma de puente con insertos naranjas - Poignée à pont avec inserts oranges - Brückengriff mit orangefarbenen Einsätzen	29

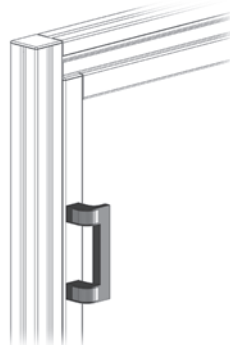
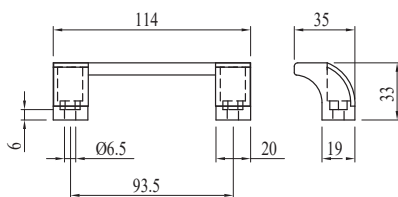
Black polyamide
Juodas poliamidas
Poliamida color negro
Polyamide noir
Schwarzes Polyamid



D FORMOS RANKENA BE ATRAMŲ

MANIGLIA ASIDERO POIGNÉE
GRIFF

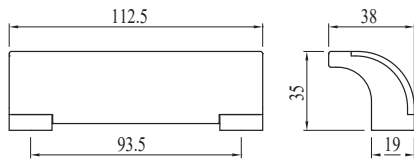

Kodas	Pastaba	g
084.506.005A	C	46
084.506.005B	D	46
084.506.005N	A	46

Black polyamide
Juodas poliamidas
Poliamida color negro
Polyamide noir
Schwarzes Polyamid

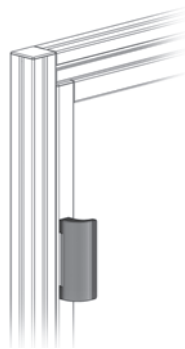

ATVIRA RANKENA

MANIGLIA ASIDERO POIGNÉE
GRIFF

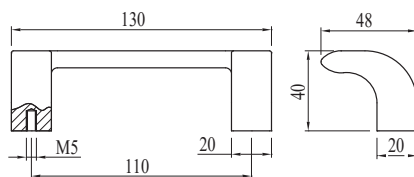

Kodas	Pastaba	g
084.506.008	Open - Atvira - Abierta - Ouverte - Offen	25

RAL 7023 polyamide
Poliamidas RAL 7023
Poliamida color RAL 7023
Polyamide RAL 7023
Polyamid RAL 7023





SPYRUOKLINĖ RANKENA

MANIGLIA A MOLLA
ASIDERO DE RESORTE
POIGNÉE À RESSORT
GRIFF MIT FEDER

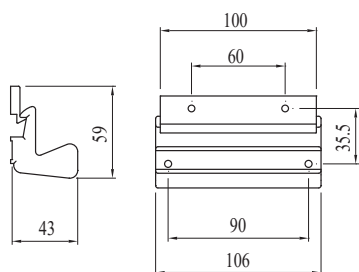

Kodas	Pastaba	g
084.506.003	Suitable for sliding door closing - Tinka stumdomų durų uždarymui- Apta para el enganche de puertas corredizas - Adaptée à la fixation de volets coulissants - Zum Schließen von Schiebetüren geeignet	185

Black painted steel, grey polyamide
Juodai dažytas plienas, pilkas poliamidas
Aluminio barnizado en negro y poliamida color gris
Aluminium peint noir polyamide gris
Aluminium – schwarz lackiert und Polyamid grau

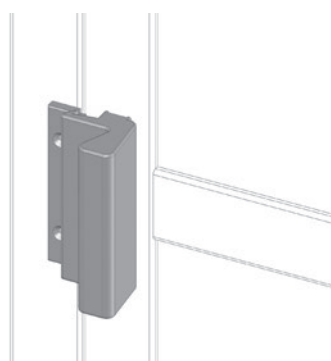
ANODIZUOTA VAMZDINĖ RANKENA
35x220

MANIGLIA A TUBO ASIDERO DE TUBO
POIGNÉE À TUBE ROHRGRIFF

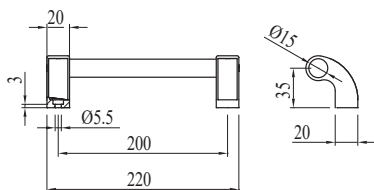

Kodas	Pastaba	g
084.506.007N	Ø15 mm anodised tube - Anodizuotas vamzdis Ø15 - Tubo anodizado Ø15 - Tube anodisé Ø 15 - Eloxiertes Rohr Ø15	65

Anodised aluminium
Anodizuotas aliuminis
Aluminium anodisé
Eloxiertes Aluminium
L=6040 mm Aluminium

Black polyamide
Juodas poliamidas
Poliamida color negro
Polyamide noir
Schwarzes Polyamid

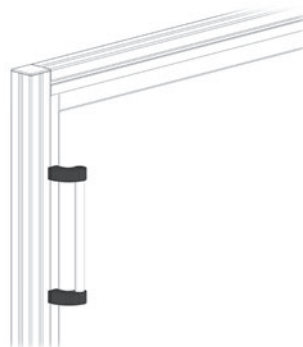

**GUMUOTA VAMZDINĖ
RANKENA 35x220**

MANIGLIA A TUBO
ASIDERO DE TUBO
POIGNÉE À TUBE
ROHRGRIFF

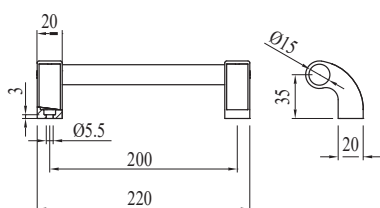

Kodas	Pastaba	g
084.506.007NR	Ø15 mm rubberised tube - Gumuotas vamzdis Ø15 - Tubo engomado Ø15 - Tube caoutchouté Ø 15 - Kautschutiertes Rohr Ø15	65

Anodised aluminium
Anodizuotas aliuminis
Aluminium anodisé
Eloxiertes Aluminium
L=6040 mm Aluminium

Black polyamide
Juodas poliamidas
Poliamida color negro
Polyamide noir
Schwarzes Polyamid

**ANODIZUOTA VAMZDINĖ
RANKENA 35x220**

MANIGLIA A TUBO ASIDERO DE TUBO
POIGNÉE À TUBE ROHRGRIFF

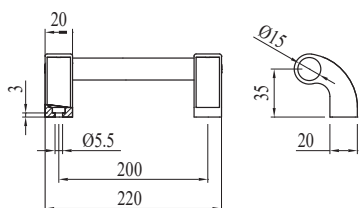

Kodas	Pastaba	g
084.506.007G	Ø15 mm anodised tube - Anodizuotas vamzdis Ø15 - Tubo anodizado Ø15 - Tube anodisé Ø 15 - Eloxiertes Rohr Ø15	65

Anodised aluminium
Anodizuotas aliuminis
Aluminium anodisé
Eloxiertes Aluminium
L=6040 mm Aluminium

Pilkas poliamidas
Poliamidas pilkas
Poliamida color gris
Polyamide gris
Graues Polyamid



GUMUOTA VAMZDINĖ RANKENA 35x220

MANIGLIA A TUBO
ASIDERO DE TUBO
POIGNÉE À TUBE
ROHRGRIFF

Kodas	Pastaba	g
084.506.007GR	Ø15 mm rubberised tube - Gumuotas vamzdis Ø15 - Tubo engomado Ø15 - Tube caoutchouté Ø15 - Kautschutiertes Rohr Ø15	65



Anodised aluminium
Anodizuotas aliuminis
Aluminium anodisé
Eloxiertes Aluminium
L=6040 mm Aluminium

Pilkas poliamidas
Poliamidas pilkas
Poliamida color gris
Polyamide gris Graues
Polyamid

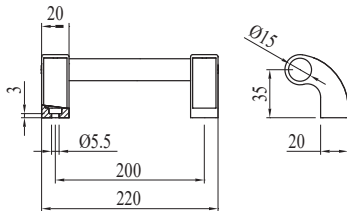



LAIKIKLIS RANKENAI

SUPPORTI PER MANIGLIA
SOPORTES PARA ASIDERO
SUPPORTS POUR POIGNÉE
HALTERUNG FÜR GRIFF



Kodas	Pastaba	g
084.506.006	For Ø32 tube - Vamzdžiui Ø32 - Para tubo Ø32 - Pour tube Ø 32 - Für Rohr Ø32	93
084.506.006G	For Ø32 mm tube - Vamzdžiui Ø32 - Para tubo Ø32 - Pour tube Ø 32 - Für Rohr Ø32	93

Black polyamide
Juodas poliamidas
Poliamida color negro
Polyamide noir
Schwarzes Polyamid

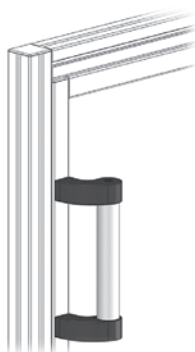
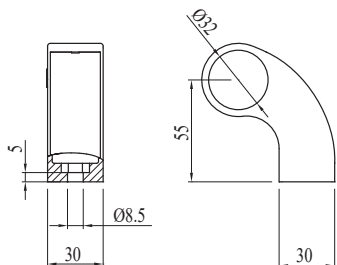

KODAS FOR ORDER COMPLETE HANDEL KIT

KODAS, NORINT UŽSAKYTI PILNĄ RANKENOS RINKINĮ / CÓDIGO PARA PEDIR EL KIT DE ASIDERO COMPLETO KODAS POUR COMMANDER KIT POIGNÉE COMPLÈTE / TEIL NR. ZUR BESTELLUNG DES KOMPLETTEN GRIFFSATZ

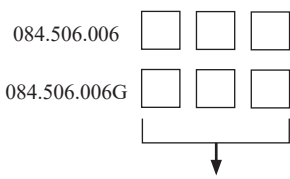

- handle complete with aluminium tube Ø32
rankena su Ø32 aliuminio vamzdžiu
- manija con tubo en aluminio Ø32
- poignée avec tube en aluminium Ø32
- Griff mit Aluminium Rohr Ø32

I distance between the supports
Atstumas tarp atramų
I distancia entre los dos soportes
I distance entre les deux supports
I Abstand zwischen den zwei Halter

Tube / **vamzdis** / tubo / tube / Rohr
A anodized / **anodizuotas** / anodizado / anodisé / eloxiert
B blu coated / **mėlynai dažytas** / pintado azul / peint en bleu / Blau lackiert
R rubberised / **gumuotas** / cauchutado / caoutchouté / gummiert

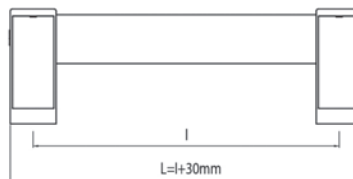

Tube / **vamzdis** / tubo / tube / Rohr = I+25mm



VAMZDIS RANKENAI Ø32

TUBO PER MANIGLIA
TUBO PARA ASIDERO
TUBE POUR POIGNÉE
ROHR FÜR GRIFF

Kodas	Pastaba	kg/m
084.506.006	PA Ø32 mm	0,35



Anodised aluminium
Anodizuotas aliuminis
Aluminium anodisé
Eloxiertes Aluminium
L=6040 mm

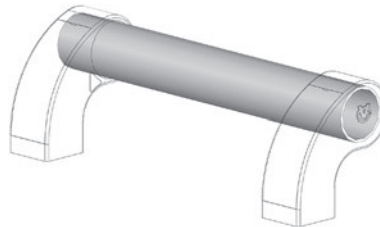
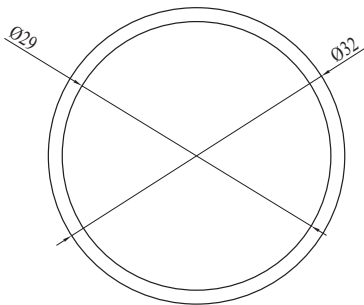

MĒLYNAI DAŽYTAS VAMZDIS RANKENAI Ø32

TUBO PER MANIGLIA
TUBO PARA ASIDERO
TUBE POUR POIGNÉE
ROHR FÜR GRIFF

Kodas	Pastaba	kg/m
059.032.029	Ø32 mm	0,35



Blue painted aluminium
Aluminio dažytas mėlynai
Aluminio barnizado en azul
Aluminium peint bleu
Lackiertes Aluminium blau
L=2000mm

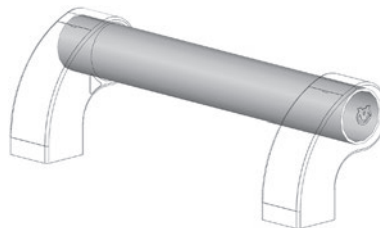
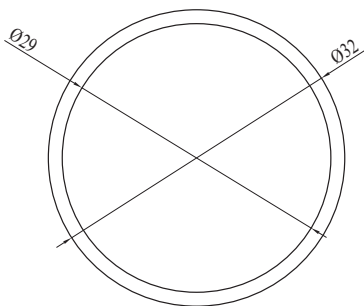

**GUMINIS VAMZDŽIO APVALKALAS, Ø 32 mm**

GUAINA PER TUBO REVESTIMENTO
 PARA TUBO Ø 32
 GAINE POUR TUBE Ø 32
 HÜLLE FÜR ROHR Ø32

Kodas	Pastaba	g/m
084.506.006R	Ø 32 mm	30

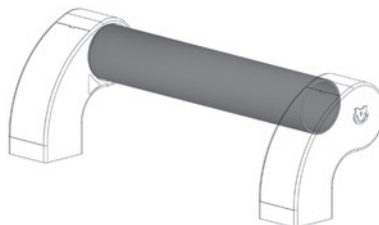
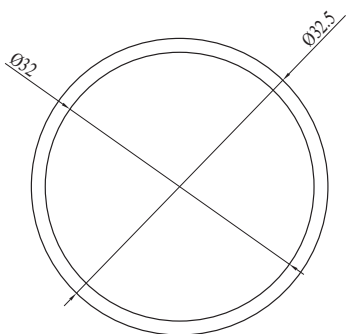

Heat-shrink black rubber
 Juoda susitraukianti guma
 Goma negra termorretráctil
 Caoutchouc noir thermorétractable
 Wärmeschrumpf schwarzer Gummi

**ATRAMA RANKENAI Ø25 VAMZDŽIUI**

SUPPORTI PER MANIGLIA SOPORTES PARA ASIDERO
 SUPPORTS POUR POIGNÉE HALTERUNG FÜR GRIFF

Kodas	Pastaba	g
084.506.009A	For Ø25 tube - Vamzdžiui Ø25 - Para tubo Ø25 - Pour tube Ø25 - Für Rohr Ø25	9,6

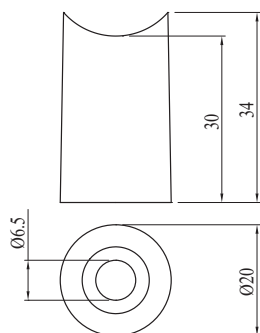
**PA6+GF, RAL 7023**



RANKENOS DANGTELIS Ø25 VAMZDŽIUI

TAPPI MANIGLIA
TA PAS MANEJAR
EMBOUTS POIGNÉE
ABDECKKAPPEN FÜR GRIFF

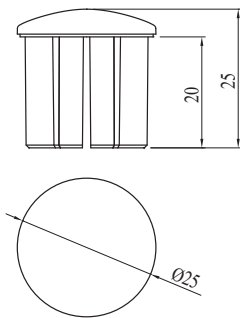

Kodas	Pastaba	g
084.506.009B	For Ø25 tube - Vamzdžiui Ø25 - Para tubo Ø25 - Pour tube Ø25 - Für Rohr Ø25	4,7

PA6+GF, RAL 7023



VAMZDIS RANKENAI Ø25

TUBO PER MANIGLIA
TUBO PARA ASIDERO
TUBE POUR POIGNÉE
ROHR FÜR GRIFF

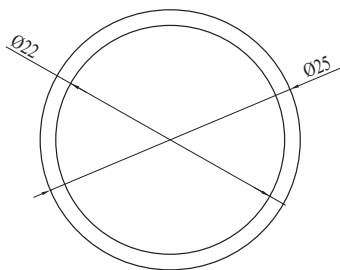

Kodas	Pastaba	g
084.506.009	PA Ø25 mm	0,3

Anodised aluminium
Anodizuotas aliuminis
Aluminium anodisé
Eloxiertes Aluminium
L=6040 mm



**DURŲ VARČIOS SPYNA**

SCROCCHETTO CHIUDI
 ANTA CIERRE
 LOQUET FERMETURE
 BATTANT TÜRVERSCHLUSS

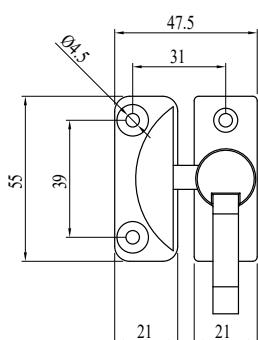

Kodas	Pastaba	g
084.517.001	1 RH + 1 LH complete with self-tapping screws - 1 dešinyšis + 1 kairysis su savisriegiais varžtais - 1 droit + 1 gauche doté de vis taraudeuses 1 dcho. + 1 izdo., incluye tornillos autorroscantes - 1 Re + 1 Li einschließlich gewindeformender Schrauben	34

Black polyamide
 Juodas poliamidas
 Poliamida color negro
 Polyamide noir
 Schwarzes Polyamid

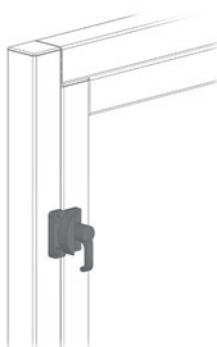
**SPYRUOKLINIS UŽRAKTAS**

SCROCCHETTO A MOLLA CIERRE
 DE RESORTE
 LOQUET À RESSORT
 FEDERVERSCHLUSS

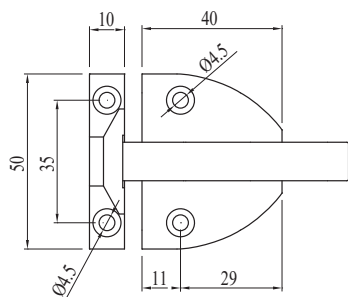

Kodas	Pastaba	g
084.518.002	Complete with self-tapping screws - Su savisriegiais varžtais - Incluye tornillos autorroscantes - Doté de vis taraudeuses - Einschließlich gewindeformender Schrauben	33

Black polyamide
 Juodas poliamidas
 Poliamida color negro
 Polyamide noir
 Schwarzes Polyamid





UŽRAKTAS KOMPLEKTE SU RAKTU

SERRATURA A CHIAVE CERRADURA DE LLAVE
SERRURE À CLÉ SCHLÜSSELSCHLOSS

Kodas	Pastaba	g
084.519.001	Complete with key - Komplekte su raktu - Incluye llave - Doté de clé - Einschließlich Schlüssel	190



Galvanised steel
Cinkuotas plienas
Acero galvanizado
Acier zingué
Verzinkter Stahl

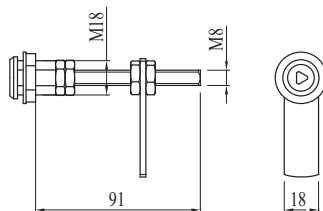

UŽRAKTAS (KOMPLEKTE NĖRA RAKTO)

SERRATURA A CHIAVE CERRADURA DE LLAVE
SERRURE À CLÉ SCHLÜSSELSCHLOSS

Kodas	Pastaba	g
013.100.030	Key not included - Be raktu - Clave no incluida - Clé non fournie - Schlüssel nicht inklusiv	46



Galvanised steel
Cinkuotas plienas
Acero galvanizado
Acier zingué
Verzinkter Stahl

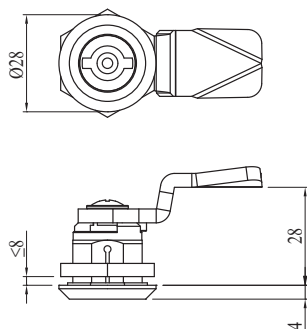

Lavorazione su pannello

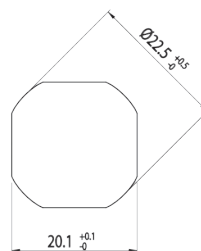

Chiave - Key - Llave - Clé - Schlüssel			
			
Kodas	Medž.	g	Sp.
013.100.031	Zamak	0,5	A



UŽRAKTAS (KOMPLEKTE NĖRA RAKTO)

SERRATURA A CHIAVE CERRADURA DE LLAVE
SERRURE À CLÉ SCHLÜSSELSCHLOSS

Kodas	Pastaba	g
013.100.032	Key not included - Be raktas - Clé nonfournie - Schlüssel nicht inklusiv	81



Galvanised steel
Cinkuotas plienas
Acero galvanizado
Acier zingué
Verzinkter Stahl

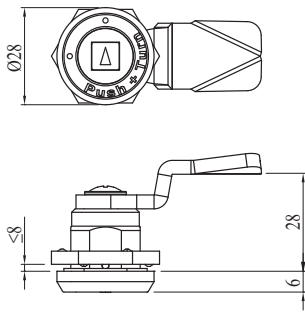

Lavorazione su pannello

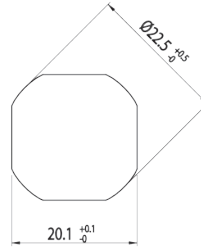

Chiave - Key - Llave - Clé - Schlüssel			
Kodas	Medž.	g	Sp.
013.100.033	Zamak	0,5	A

DURŲ UŽDARYMO SPAUSTUKAI

CLIPS FERMAPORTE
CLIPS DE TOPE DE PUERTAS CLIPS DE
FERMETURE PORTES TÜRSTOPPERCLIPS

Kodas	Pastaba	g
084.519.002	Complete with strike plate -Komplektuojama su spynos plokštele- Incluye placa de apoyo - Doté de plaqueette d'appui - Einschließlich Tragplatte	39

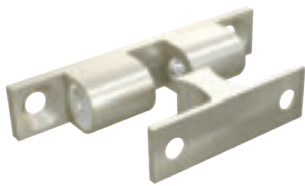

Brass
Žalvaris
Latón
Laiton
Messing

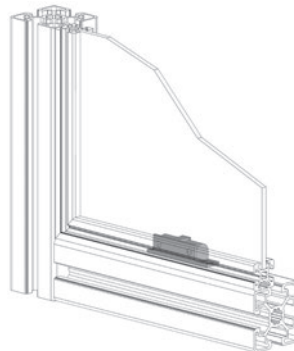
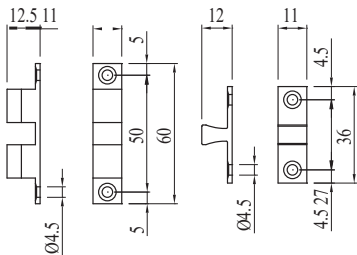



DURŲ UŽDARYMO SPAUSTUKAI

CLIPS FERMAPORTE
CLIPS DE TOPE DE PUERTAS CLIPS DE FERMETURE
PORTES TÜRSTOPPERCLIPS

Kodas	Pastaba	g
084.519.008	With base plate - Su pagrindo plokšte - Con placa base - Avec plaque d'appui - Mit Stützplatte	55

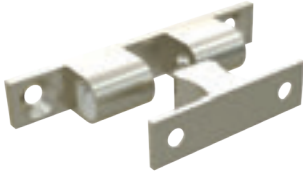

Brass
Žalvaris
Latón
Laiton
Messing

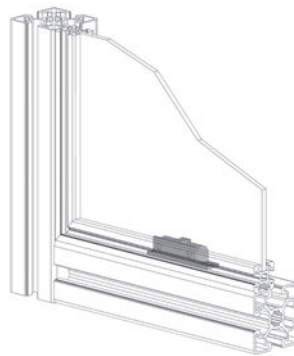
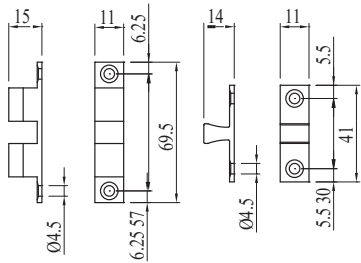

MAGNETINIS DURŲ UŽDARYTUVAS

FERMAPORTE A CALAMITA TOPE CON IMÁN
FERMETURE PORTES À AIMANT
MAGNETISCHER TÜRSTOPPER

Kodas	Pastaba	g
084.525.001	Complete with strike plate and magnet - Komplekte su spynos plokšte ir magnetu - Incluye placa de apoyo e imán - Doté de plaquette d'appui et d'aimant - Einschließlich Tragplatte und Magnet	37



Reinforced polyamide
Sustiprintas poliamidas
Poliamida reforzada
Polyamide renforcé
Verstärktes Polyamid

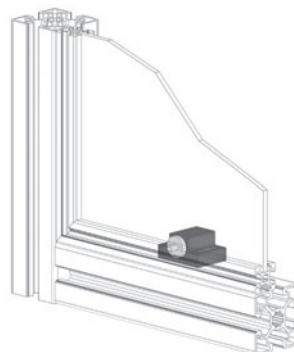
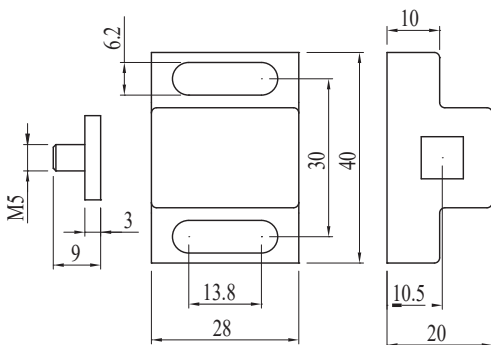



DURŲ UŽDARYTUVAS

FERMAPORTE CON SFERA
TOPE DE PUERTA FERMETURE
PORTES TÜRSTOPPER

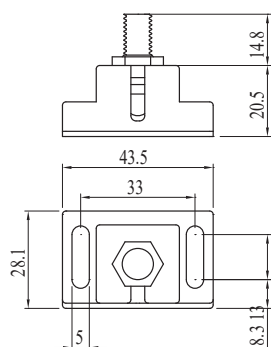

Kodas	Pastaba	g
084.519.007	M8 threaded pin included - Pridedamas M8 srieginis kaištis - Perno roscado M8 incluido - Pivot fileté M8 fourni - Gewindestift M8 enthalten	35

Black polyamide
Juodas poliamidas
Poliamida color negro
Polyamide noir
Schwarzes Polyamid

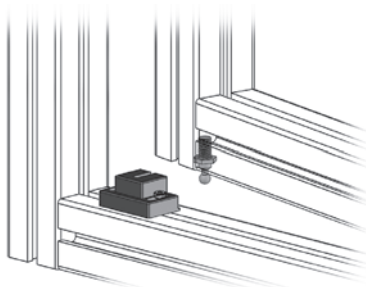

DURŲ UŽDARYTUVAS

FERMAPORTE CON SFERA TOPE DE
PUERTA FERMETURE PORTES
TÜRSTOPPER

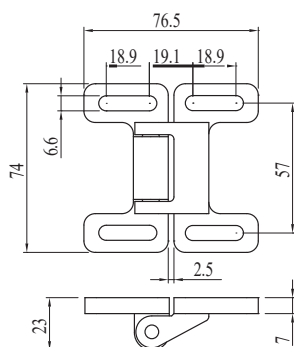

Kodas	Pastaba	g
084.519.006	Fastening with M6 screws, not included - Tvirtinimas M6 varžtais, nepridedami- Fijación con tornillos M6, no incluidos - Montage avec vis M6, non fournies - Montage mit Schrauben M6, nicht enthalten	120

Black polyamide
Juodas poliamidas
Poliamida color negro
Polyamide noir
Schwarzes Polyamid

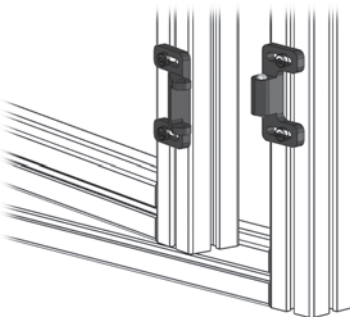

**DURŲ UŽDARYTUVAS**

FERMAPORTE
TOPE DE PUERTA
FERMETURE PORTES
TÜRSTOPPER

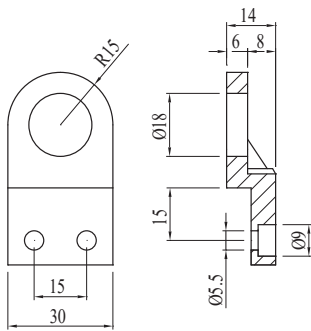

Kodas	Pastaba	g
084.522.002	For M18 magnet - Magnetui M18 - Para imán M18 - Pour aimant M18 - Für Magnet M18	11

Pilkas poliamidas
Poliamidas pilkas
Poliamida color gris
Polyamide gris Grau
Polyamid

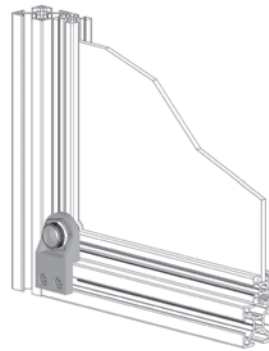
**DURŲ UŽDARYTUVAS**

FERMAPORTE TOPE DE PUERTA
FERMETURE PORTES
TÜRSTOPPER

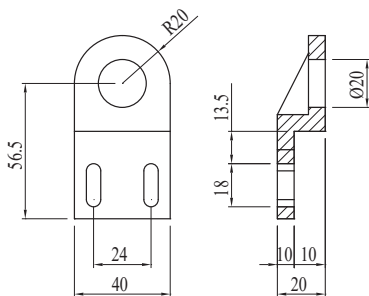

Kodas	Pastaba	g
084.522.001	For M18 magnet - Magnetui M18 - Para imán M18 - Pour aimant M18 - Für Magnet M18	27

Pilkas poliamidas
Poliamidas pilkas
Poliamida color gris
Polyamide gris Grau
Polyamid

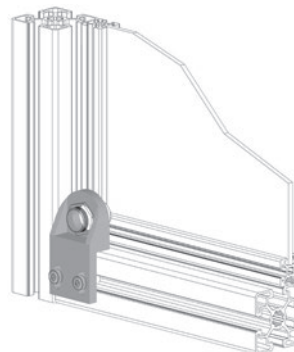



DURŲ UŽDARYTUVAS

FERMAPORTE TOPE DE
PUERTA FERMETURE
PORTES TÜRSTOPPER

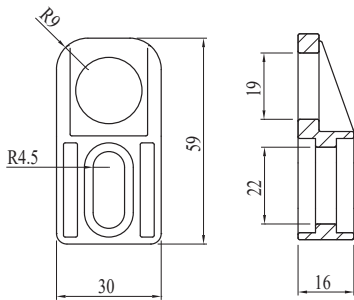

Kodas	Pastaba	g
084.522.003	For M18 magnet -Magnetui M18 - Para imán M18 - Pour aimant M18 - Für Magnet M18	12

Black polyamide
Juodas poliamidas
Poliamida color negro
Polyamide noir
Schwarzes Polyamid

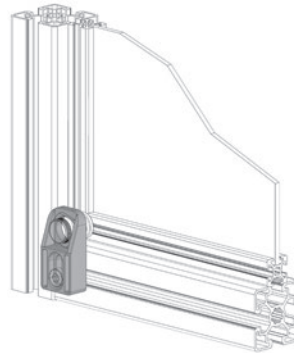

MAGNETAS

MAGNETE
IMÁN
AIMANT
MAGNET

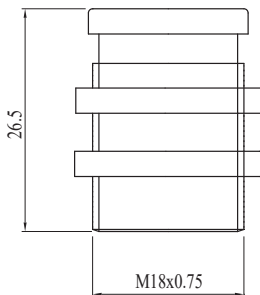

Kodas	Pastaba	g
084.523.001	Attractive force 70 N - Pritraukimo galia 70 N - Fuerza de atracción 70 N - Force attractive 70 N - Anziehungskraft 70 N	52

Zinc plated steel
Cinkuotas plienas
Acero galvanizado
Acier zingué
Verzinkter Stahl

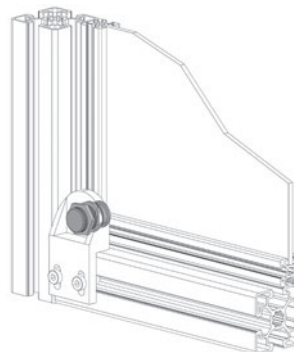



DURŲ UŽDARYTUVAS SU MAGNETU

FERMAPORTE CON MAGNETE TOPE DE PUERTA CON
IMÁN FERMETURE PORTES À AIMANT TÜRSTOPPER
MIT MAGNET

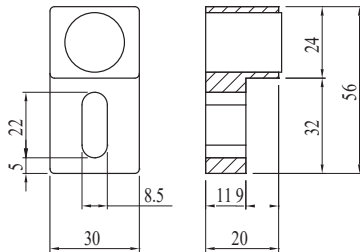

Kodas	Pastaba	g
084.524.001	Complete with magnet, Pritraukimo galia 50 N - Komplekte su magnetu, Forza di attrazione 50 N - Incluye imán, Fuerza de atracción 50 N - Doté d'aimant, Force attractive 50 N - Einschließlich Magnet, Anziehungskraft 50 N	70

Sandblasted aluminium
Smėliapūte apdorotas aliuminis
Aluminio arenado
Aluminium sablé
Sandgestrahltes Aluminium

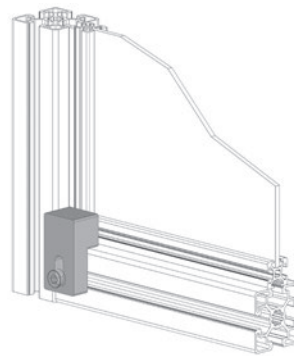

SAVARŽĖLĖS KABLIUKAS

CLIPS HOOKING
AGGANCIO A CLIPS ACOPLAMIENTO CON CLIPS
ACCROCHAGE AVEC CLIPS CLIP BEFESTIGUNG

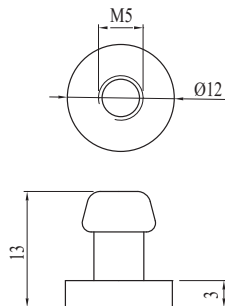

Kodas	Pastaba	g
084.523.003	Stop pin - STOP kabliukas - Perno de guía - Goupille de butée - Klemmnuss	5

Galvanised steel
Cinkuotas plienas
Acero galvanizado
Acier zingué
Verzinkter Stahl

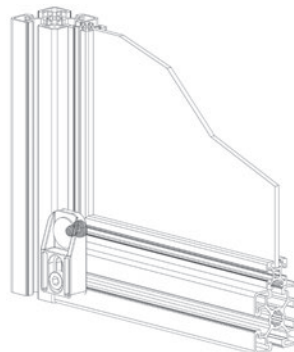



KABLIŲ SEGTUKAI

CLIPS HOOKING
 AGGANCIO A CLIPS
 ACOPLAMIENTO CON CLIPS
 ACCROCHAGE AVEC CLIPS
 CLIP BEFESTIGUNG

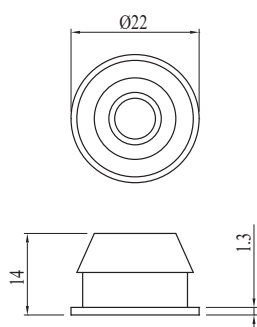

Kodas	Pastaba	g
084.523.002	Segtukas	4

Thermoplastic rubber
 Termoplastinė guma
 Goma termoplástica
 Caoutchouc thermoplastique
 Thermoplastischer Gummi

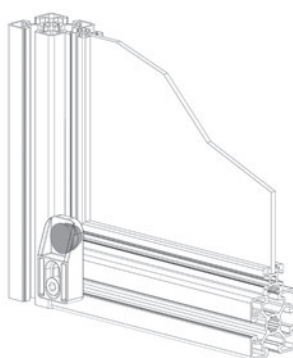

KABELIO SEGTUKAS

CABLE CLIP
 BLOCCHETTO FERMACAVI
 BLOQUE OCULTA-
 CABLES EMBASE
 KABELHALTERBLOCK

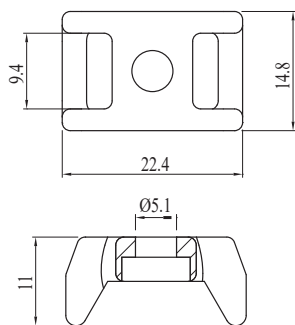

Kodas	Pastaba	g
084.510.013	Fastening with M5 screws, not included - Tvirtinimas M5 varžtais, neieina - Fijación con tornillos M5, no incluidos - Fixation avec vis M5 non fournies - Befestigung mit Schrauben M5 (nicht im Lieferumfang enthalten)	2

Pilkas poliamidas
 Poliamidas pilkas
 Poliamida color gris
 Polyamide gris Grau
 Polyamid





KABELIO SURIŠĖJAS

BH 10 40 BH L 10 45 BH H 10 45 BH 10 50

CLIP CABLE BINDER
BLOCCHETTO FERMACAVI
BLOQUE DE FIJACIÓN
CABLES BLOC FIDE CABLES
CLIP-KABELBINDER

Kodas	Pastaba	g
084.510.018	Segiklis	10

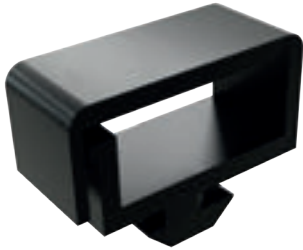

Black polyamide
Juodas poliamidas
Poliamida color negro
Polyamide noir
Schwarzes Polyamid

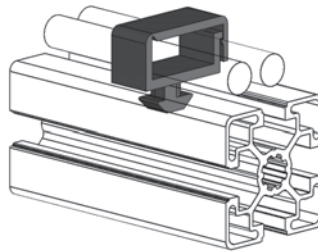
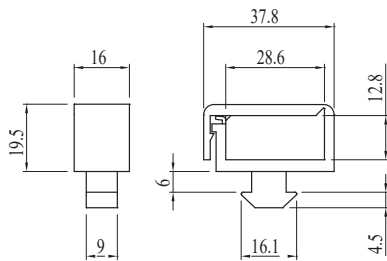

KABELIO SURIŠĖJAS

BH 10 40 BH L 10 45 BH H 10 45 BH 10 50

CLIP CABLE BINDER
BLOCCHETTO FERMACAVI
BLOQUE DE FIJACIÓN
CABLES BLOC FIDE CABLES
CLIP-KABELBINDER

Kodas	Pastaba	g
084.510.019	Segiklis	13



Black polyamide
Juodas poliamidas
Poliamida color negro
Polyamide noir
Schwarzes Polyamid

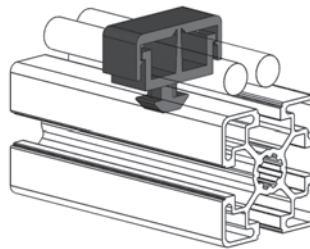
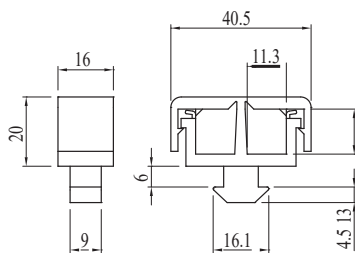



KABELIO SURIŠĖJAS

BH 10 40 BH L 10 45 BH H 10 45 BH 10 50

CLIP CABLE BINDER
BLOCCHETTO FERMACAVI
BLOQUE DE FIJACIÓN
CABLES BLOC FIDE CABLES
CLIP-KABELBINDER

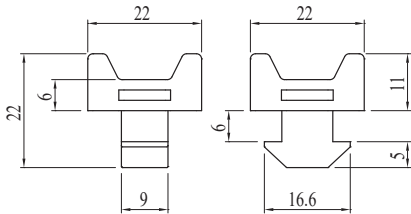

Kodas	Pastaba	g
084.510.021	Fasten with plastic tie - Tvirtinimas plastiko raiščiu - Fijar con brida de plastico - Fixation avec collier de serrage en plastique - Befestigung mit Kabelbinder	8

Black polyamide
Juodas poliamidas
Poliamida color negro
Polyamide noir
Schwarzes Polyamid

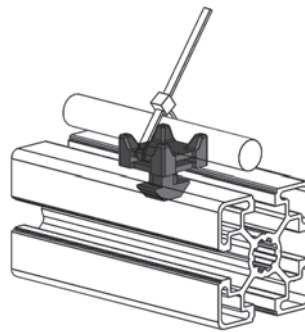

ĮRANKIŲ LAIKIKLIS 64,5x56

BH 6 20

TOOL HANGER
PORTA UTENSILI MOSQUETÓN DESLIZANTE
MOUSQUETON PORTE OUTILS
WERKZEUGGLEITER

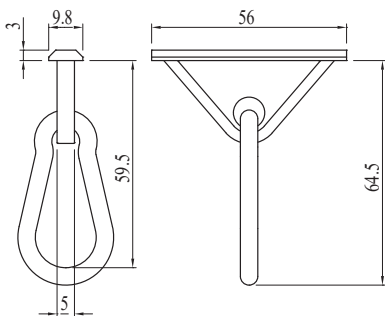

Kodas	Pastaba	g
084.535.004	Sliding - Slankiojantis - Deslizante - Coulissant - Verschiebbar	32

Black polyamide
Juodas poliamidas
Poliamida color negro
Polyamide noir
Schwarzes Polyamid

Galvanised steel
Cinkuotas plienas
Acero galvanizado
Acier zingué
Verzinkter Stahl

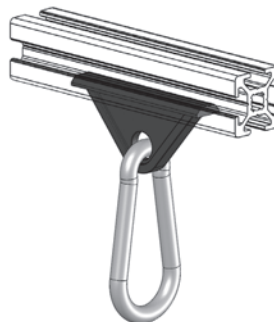

ĮRANKIŲ LAIKIKLIS 84,4x65



TOOL HANGER
 PORTA UTENSILI MOSQUETÓN
 DESLIZANTE MOUSQUETON PORTE
 OUTILS WERKZEUGGLEITER

Kodas	Pastaba	g
084.535.005	Sliding - Slankiojantis - Deslizante - Coulissant - Verschiebbar	43

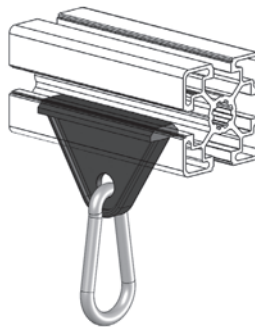
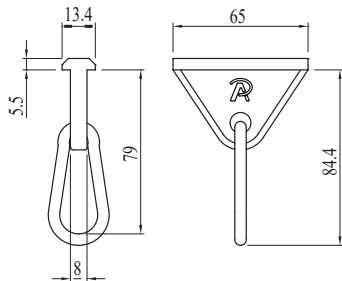

Black polyamide
 Juodas poliamidas
 Poliamida color negro
 Polyamide noir
 Schwarzes Polyamid

Galvanised steel
 Cinkuotas plienas
 Acero galvanizado
 Acier zingué
 Verzinkter Stahl

ĮRANKIŲ LAIKIKLIS 91x65



TOOL HANGER
 PORTA UTENSILI MOSQUETÓN
 DESLIZANTE MOUSQUETON PORTE
 OUTILS WERKZEUGGLEITER

Kodas	Pastaba	g
084.535.006	Sliding - Slankiojantis - Deslizante - Coulissant - Verschiebbar	43

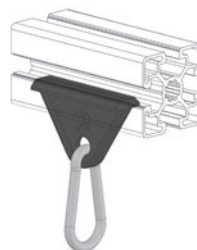
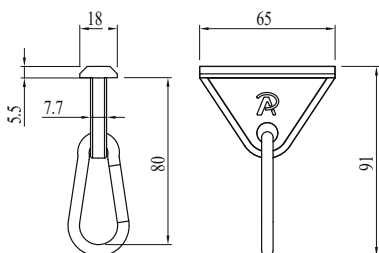

Black polyamide
 Juodas poliamidas
 Poliamida color negro
 Polyamide noir
 Schwarzes Polyamid

Galvanised steel
 Cinkuotas plienas
 Acero galvanizado
 Acier zingué
 Verzinkter Stahl





DUJINĖ SPRYRUOKLĖ

GAS SPRING
MOLLA A GAS
MUELLE DE GAS
RESSORT À GAZ
GASFEDER



Kodas	N	A	B	g
084.527.001	50	110	263	96
084.527.002	100	110	263	96
084.527.003	150	110	263	96
084.527.004	200	110	263	95
084.527.005	250	110	263	95
084.527.006	300	110	263	97
084.527.007	100	115	305	109
084.527.008	100	142	365	190
084.527.009	200	142	365	190
084.527.010	250	142	365	194
084.527.011	300	142	365	194
084.527.012	350	142	365	194
084.527.013	250	200	483	237
084.527.014	350	200	483	237

Other models available on request
Kiti modeliai galimi pagal pageidavimą
Bajo solicitud pueden suministrarse otros modelos Autres
modèles disponibles sur demande
Auf Anfrage können weitere Modelle geliefert werden

CALCOLO PER IL MONTAGGIO DI UNA MOLLA A GAS

GAS SPRING INSTALLATION CALCULATION / CÁLCULO PARA EL MONTAJE DE UN MUELLE DE GAS
CALCUL POUR LE MONTAGE D'UN RESSORT À GAZ / BERECHNUNG FÜR DIE MONTAGE EINER GASDRUCKFEDER

Definizione della forza di estensione F1 (N) a 20° C

Defining the extension force F1 (N) at 20° C
Definición de la fuerza de extensión F1 (N) a 20 °C
Définition de la force d'extension F1 (N) à 20°C
Definition der Dehnungskraft F1 (N) bei 20° C

$$F1 = \frac{G \times D}{b \times n} \times 13 \text{ (N)}$$

G = Peso del portellone in Kg

Weight of door in kg / Peso de la puerta en kg / Poids du battant en kg / Gewicht der Klappe in kg

L = Distanza fra il baricentro ed il punto di rotazione in mm

L = Distance between the centre of gravity and point of rotation in mm / Distancia entre el centro de gravedad y el punto de rotación en mm / Distance entre le barycentre et le point de rotation en mm / Abstand zwischen Schwerpunkt und Drehpunkt in mm

b = Braccio di leva utile della molla a gas in mm, portellone aperto

b = Effective lever arm of gas spring in mm with door open / Brazo de palanca útil del muelle de gas en mm, con la puerta abierta / Bras de levier utile du ressort à gaz en mm, battant ouvert / Nutzhebelarm der Gasdruckfeder in mm, geöffnete Klappe

13 = Coefficiente di conversione kg - N + riserva di sicurezza

13 = kg to N conversion factor + safety margin / Coeficiente de conversión kg - N + reserva de seguridad
Coefficient de conversion kg - N + marge de sécurité / Umrechnungsfaktor kg - N + Sicherheitsmarge

P = Fissaggio del portellone ca.2/3 L

P = Connection to door at approx. 2/3 of L / Fijación de la puerta en 2/3 L aprox. / Fixation du battant environ 2/3 L / Befestigung der Klappe ca.2/3 L

n = Numero delle molle a gas (Standard: n = 2)

n = Number of gas springs (2 x standard) / Número de muelles de gas (estándar: n = 2) / Nombre de ressorts à gaz (Standard : n = 2) / Anzahl der Gasdruckfedern (Standard: n = 2)

D = Braccio di leva utile della forza di gravità in mm, portellone aperto

D = Effective lever arm of force of gravity in mm with door open / Brazo de palanca útil de la fuerza de gravedad en mm, con la puerta abierta / Bras de levier utile de la force de gravité en mm, battant ouvert / Nutzhebelarm der Schwerkraft in mm, geöffnete Klappe

Esempio

Example / Ejemplo / Exemple / Beispiel

G = 30 kg, D = 400 mm, b = 200 mm, n = 2

$$F1 = \frac{30 \times 400}{200 \times 2} \times 13 = 390 \text{ N}$$

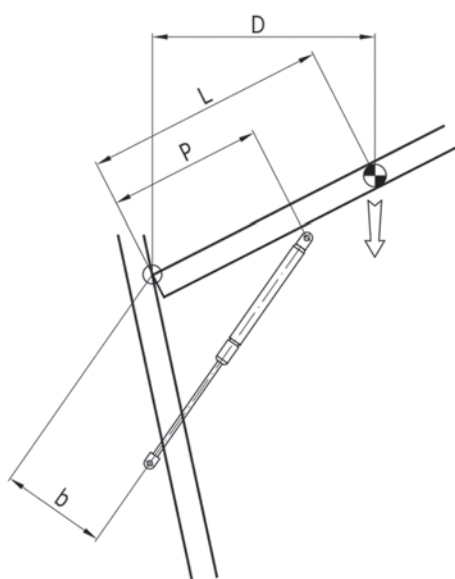
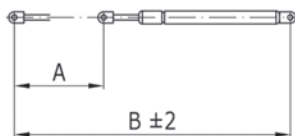



DUJINĖS SPYRUOKLĖS ATRAMA

GAS SPRING SUPPORT
SUPPORTO PER MOLLA A GAS
SOPORTE PARA MUELLE DE GAS
SUPPORT POUR RESSORT À GAZ
HALTERUNG FÜR GASFEDER

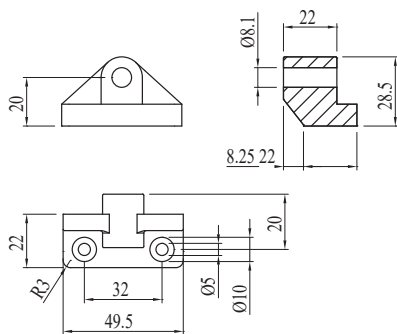

Kodas	Pastaba	g
084.528.001	Use with 084.528.002 - Naudojama su 084.528.002 - Utilizar con 084.528.002 - Utiliser avec 084.528.002 - Verwenden mit 084.528.002	21

Pilkas poliamidas
Poliamidas pilkas
Poliamida color gris
Polyamide gris
Grau Polyamid

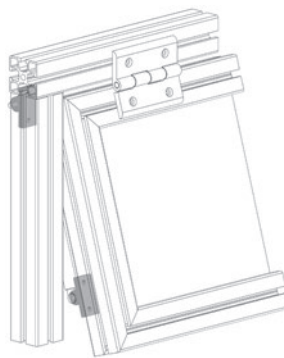

ATRAMINIS KAIŠTIS

SUPPORT PIN
PERNO SUPPORTO PERNO
SOPORTE PIVOT SUPPORT
AUFNAHMEBOLZEN

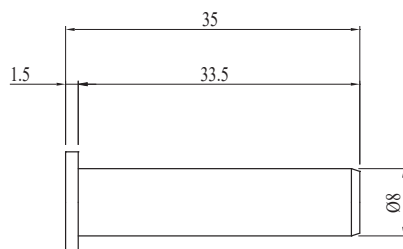

Kodas	Pastaba	g
084.528.002	For support 084.528.001 - Atramai 084.528.001 - Para soporte 084.528.001 - Pour support 084.528.001 - Für Halterung 084.528.001	14

Galvanised steel
Cinkuotas plienas
Acero galvanizado
Acier zingué
Verzinkter Stahl

Washer included
Su poveržle
Arandela incluida
Rondelle fournie
Unterlegscheibe im Lieferumfang enthalten

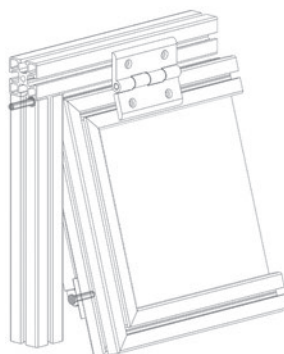



DUJINĖS SPYRUOKLĖS ATRAMA

GAS SPRING SUPPORT
SUPPORTO PER MOLLA A GAS
SOPORTE PARA MUELLE DE GAS
SUPPORT POUR RESSORT À GAZ
HALTERUNG FÜR GASFEDER

Kodas	Pastaba	g
084.528.003	With Ø6 mm pin. - Su kaiščiū Ø6 - Con perno Ø6. - Avec axe Ø 6 - Mit Bolzen Ø6.	18



Gray polyamide and galvanised steel
Poliamidas pilkas ir cinkuotas plienas
Poliamida color gris y acero galvanizado
Polyamide gris et acier zingué
Graues Polyamid und verzinkter Stahl

For small gas springs
Mažoms dujinėms spyruoklėms
Para pequeñas muelles de gas
Pour petites ressorts à gaz
Für kleine Gasfedern

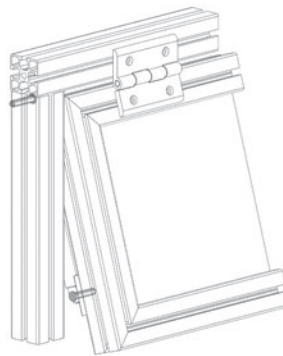
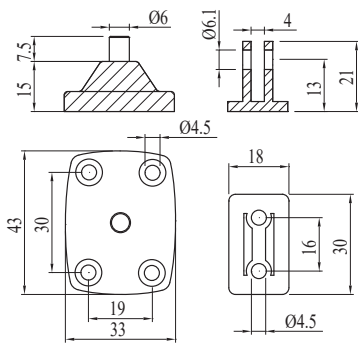

DUJINĖS SPYRUOKLĖS ATRAMA

GAS SPRING SUPPORT
SUPPORTO PER MOLLA A GAS
SOPORTE PARA MUELLE DE GAS
SUPPORT POUR RESSORT À GAZ
HALTERUNG FÜR GASFEDER

Kodas	Pastaba	g
084.528.004	With Ø8 mm pin - Su kaiščiū Ø8 - Con perno Ø8 - Avec axe Ø 8 - Mit Bolzen Ø8	63



Pilkas poliamidas and galvanised steel
Poliamidas pilkas ir cinkuotas plienas
Poliamida color gris y acero galvanizado
Polyamide gris et acier zingué
Graues Polyamid und verzinkter Stahl

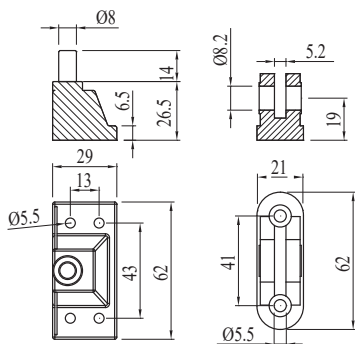



SAUGOS JUNGIKLIS SU 1 KONTAKTU NC

INTERRUTTORE DI SICUREZZA INTERRUPTOR DE
SEGURIDAD INTERRUPTEUR DE SÉCURITÉ
SICHERHEITSSCHALTER



Kodas	Pastaba	g
084.601.001	Limit switch, 1 contact, NC -Ribinis jungiklis su 1 NC kontaktu - Final de carrera de 1 contacto NC - Fin de course à 1 contact NF - Endschalter mit 1 Kontakt NC	160

SAUGOS JUNGIKLIS SU 2 KONTAKTAIS 1NC + 1NA

INTERRUTTORE DI SICUREZZA INTERRUPTOR
DE SEGURIDAD INTERRUPTEUR DE SÉCURITÉ
SICHERHEITSSCHALTER



Kodas	Pastaba	g
084.601.002	Limit switch, 2 contacts, 1NC + 1NO - Ribinis jungiklis su 2 kontaktais 1NC + 1NA - Final de carrera de 2 contactos, 1 NC + 1 NA - Fin de course à 2 contacts 1 NF + 1 NO - Endschalter mit 2 Kontakten 1 NC + 1 NO	184

**SAUGOS JUNGIKLIS SU 3 KONTAKTAIS 2NC + 1NA**

MICRO DI SICUREZZA MICROINTERRUPTOR DE
SEGURIDAD
MICRO-CONTACTEUR DE SÉCURITÉ
SICHERHEITSMIKROSCHALTER



Kodas	Pastaba	g
084.601.003	Limit switch, 3 contacts, 2NC + 1NO - Ribinis jungiklis su 3 kontaktais 2NC + 1NA - Final de carrera de 3 contactos, 2 NC + 1 NA - Fin de course à 3 contacts 2 NF + 1 NO - Endschalter mit 3 Kontakten 2 NC + 1 NO	143

SAUGOS JUNGIKLIS SU 2 KONTAKTAIS 2NC

MICRO DI SICUREZZA MICROINTERRUPTOR DE
SEGURIDAD MICRO-CONTACTEUR DE SÉCURITÉ
SICHERHEITSMIKROSCHALTER



Kodas	Pastaba	g
084.602.001	Safety switch with 2 NC contacts - Saugos jungiklis su 2 kontaktais NC - Interruptor de seguridad de 2 contactos NC - Interrupteur de sécurité à 2 contacts NF - Sicherheitsschalter mit 2 Kontakten NC	131



GALINIS MIKROJUNGKLIŠ SU 2 KONTAKTAIS INC+INO

MICRO ROTATIVO DI SICUREZZA MICROINTERRUPTOR ROTATIVO DE SEGURIDAD
MICRO-CONTACTEUR ROTATIF DE SÉCURITÉ
SICHERHEITSMIKRODREHSCHALTER



Kodas	Pastaba	g
084.603.001	Limit switch for hinge axis with 2 contacts, 1NC+1NO - Galinis jungiklis vyrių ašiai su 2 kontaktais 1NC+1NA - Final de carrera para ejes bisagra con 2 contactos, 1 NC+1 NA - Fin de course pour axes charnière à 2 contacts 1 NF+1 NO - Endschalter für Scharnierachsen mit 2 Kontakten 1 NC+1 NO	96

KAIŠTIS SAUGOS SUKAMAJAM MIKROJUNGKLIUI

PERNO PER MICRO ROTATIVO
PERNO PARA MICROINTERRUPTOR ROTATIVO PIVOT POUR MICRO-
CONTACTEUR ROTATIF BOLZEN FÜR MIKRODREHSCHALTER



Kodas	Pastaba	g
084.531.001	For hinges 084.500.001 - 2 - 3 - 4 - 5 - 6 - Vyriams 084.500.001 - 2 - 3 - 4 - 5 - 6 - Para bisagras 084.500.001 - 2 - 3 - 4 - 5 - 6 - Pour charnières 084.500.001 - 2 - 3 - 4 - 5 - 6 - Für Scharniere 084.500.001 - 2 - 3 - 4 - 5 - 6	91

Galvanised steel
Cinkuotas plienas
Acero galvanizado
Acier zingué
Verzinkter Stahl

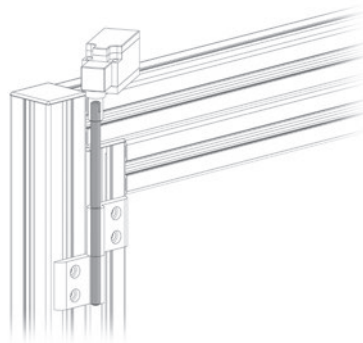
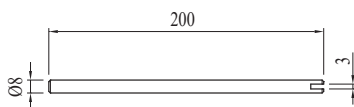

**KAIŠTIS SAUGOS SUKAMAJAM MIKROJUNGKLIUI**

PERNO PER MICRO ROTATIVO
 PERNO PARA MICROINTERRUPTOR ROTATIVO PIVOT POUR MICRO-
 CONTACTEUR ROTATIF BOLZEN FÜR MIKRODREHSCHALTER

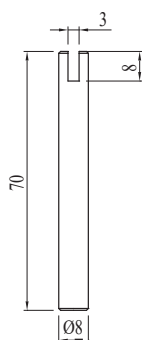

Kodas	Pastaba	g
084.533.002	Compatible with hinges 084.503.002 - 003 - Su vyriais 084.503.002 - 003 - Apto para las bisagras 084.503.002 - 003 - Adapté aux charnières 084.503.002 - 003 - Geeignet für Scharniere 084.503.002 - 003	27

Galvanised steel
 Cinkuotas plienas
 Acero galvanizado
 Acier zingué
 Verzinkter Stahl

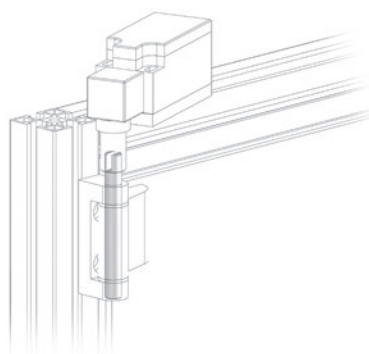
**KAIŠTIS SAUGOS SUKAMAJAM MIKROJUNGKLIUI**

PERNO PER MICRO ROTATIVO
 PERNO PARA MICROINTERRUPTOR ROTATIVO PIVOT POUR
 MICRO-CONTACTEUR ROTATIF BOLZEN FÜR
 MIKRODREHSCHALTER

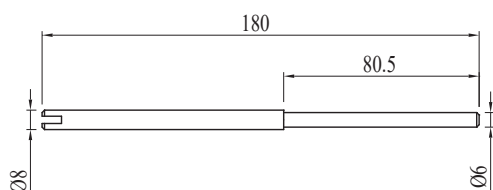

Kodas	Pastaba	g
084.608.001	Compatible with hinge 084.503.001 - Su vyriais 084.503.001 - Apto para la bisagra 084.503.001 - Adapté aux charnières 084.503.001 - Geeignet für Scharnier 084.503.001	65

Stainless steel
 Nerūdijanti plienas
 Acero inoxidable
 Acier inox
 Rostfreier Stahl

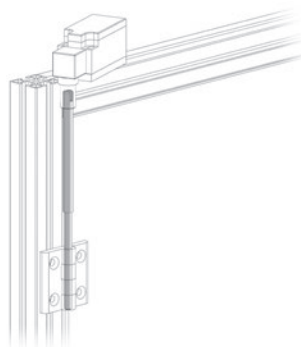



PLOKŠTĖ MIKROJUNGIKLIUI 30x30x6

PIASTRINA PER MICRO
PLACA PARA MICROINTERRUPTOR
PLAQUETTE POUR MICROCONTACTEUR
PLATTE FÜR MIKROSCHALTER

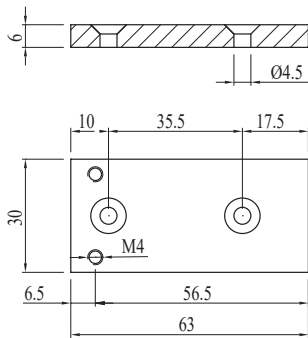
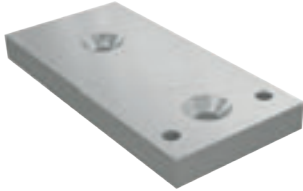

Kodas	Pastaba	g
084.604.001	Plate, th. 6 mm - Plokštelė 6 mm storio - Placa gr. 6 mm - Plaquette ép. 6 mm - Platte Dicke 6 mm	24

Aluminium
Alluminis
Aluminio
Aluminium
Aluminium

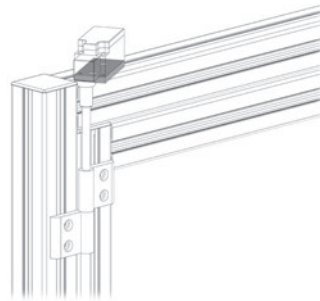

PLOKŠTĖ MIKROJUNGIKLIUI 30x63x10

PIASTRINA PER MICRO
PLACA PARA MICROINTERRUPTOR
PLAQUETTE POUR MICROCONTACTEUR
PLATTE FÜR MIKROSCHALTER

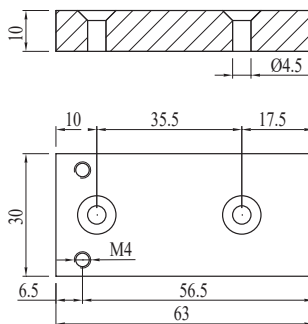
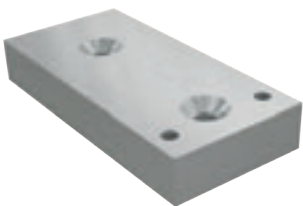

Kodas	Pastaba	g
084.604.002	Plate, th. 10 mm - Plokštės storis 10 mm - Placa gr. 10 mm - Plaquette ép. 10 mm - Platte Dicke 10 mm	52

Aluminium
Alluminis
Aluminio
Aluminium
Aluminium

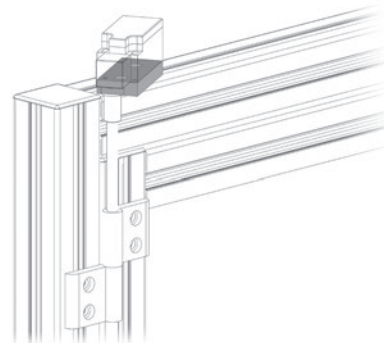



PLOKŠTĖ MIKROJUNGKLIUI 90° 40x60x8

PIASTRINA PER MICRO
PLACA PARA MICROINTERRUPTOR PLAQUETTE
POUR MICROCONTACTEUR PLATTE FÜR
MIKROSCHALTER



Kodas	Pastaba	g
084.604.003	For external fastening - Išoriniam tvirtinimui - Para fijación externa - Pour fixation externe - Für äußere Befestigung	91

Stainless steel
Nerūdijantis
plienas
Acero inoxidable
Acier inox
Rostfreier Stahl

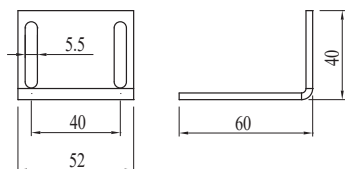



LED LEMPOS

PATENT



PROFILE
PROFILO LED
PERFIL LED
PROFILÉ LED
LED-PROFIL

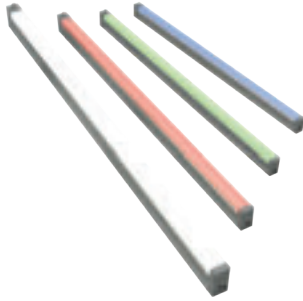

Kodas	V DC	W	Sp. (K)	L	g
700.015.4000.0250	24	3.75	4000	250	65
700.015.4000.0500	24	7.5	4000	480	120
700.015.4000.1000	24	15	4000	980	230
700.015.4000.1990	24	30	4000	1990	450
700.015.4000.2990	24	45	4000	2990	680
700.015.4000.0250G	24	3.75	F	250	65
700.015.4000.0250R	24	3.75	E	250	65
700.015.4000.0250B	24	3,75	D	250	65
700.015.4000.0500G	24	7,5	F	480	120
700.015.4000.0500R	24	7,5	E	480	120
700.015.4000.0500B	24	7,5	D	480	120

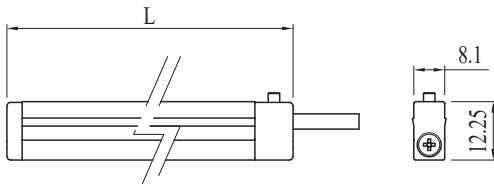

Dimmable
Pritendomos
Regulable Intensité
Variable Dimmbar

LED LEMPOS

PATENT



LED PROFILE
PROFILO LED
PERFIL LED
PROFILÉ LED
LED-PROFIL

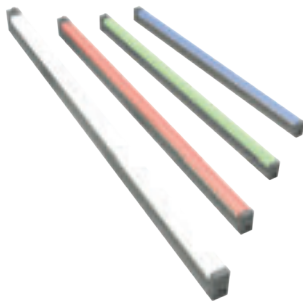

Kodas	V DC	W	Sp. (K)	L	g
700.013.4000.0250	24	3,75	4000	250	65
700.013.4000.0500	24	7,5	4000	500	120
700.013.4000.1000	24	15	4000	1000	230
700.013.4000.1990	24	30	4000	1990	450
700.013.4000.2990	24	45	4000	2990	680
700.013.4000.0250G	24	3.75	F	250	65
700.013.4000.0250R	24	3.75	E	250	65
700.013.4000.0250B	24	3,75	D	250	65
700.013.4000.0500G	24	7,5	F	500	120
700.013.4000.0500R	24	7,5	E	500	120
700.013.4000.0500B	24	7,5	D	500	120

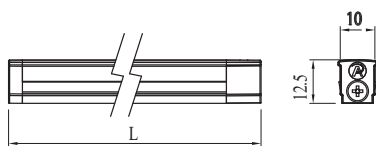

Dimmable
Pritendomos
Regulable Intensité
variable Dimmbar



LED SIGNAL I. 500 mm

LED SEGNALAZIONE L.500MM
LED SEÑAL L.500MM
LED SIGNALISATION L.500MM LED
ANZEIGE L.500 MM

NEW

Kodas	V	W	L	g
800.019.449	24	22,5	575,5	2000

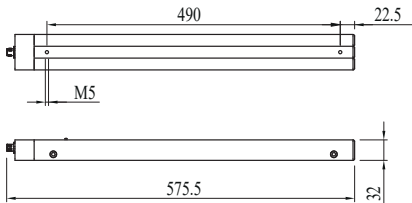
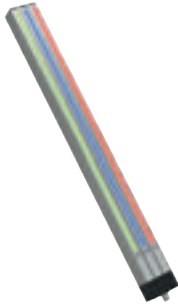

Authorized access
Igalota prieiga
Acceso autorizado
Accès autorisé
Autorisierten Zugriff



Unauthorized access
Nejgalota prieiga
Acceso no autorizado
Accès non autorisé
Unbefugten Zugriff



Fully operational
Pilnkai veikianti
Plenamente operativo
Pleinement opérationnel
Voll funktionsfähig



Non-operating
Neveikianti
Inoperativo
Non opérationnel
Nicht betriebsbereit



Under maintenance
Atliekama techninė priežiūra
En mantenimiento
En maintenance
Im Wartungsmodus



GALIOS BLOKAS

ALIMENTATORE
ALIMENTADOR
ALIMENTATEUR
NETZTEIL

Kodas	V	W	VAC	A	B	C	g
700.024.020	24	20,20	90-264	118	26	35	0,22
700.024.060	24	60	90-264	162,5	32	42,50	0,40

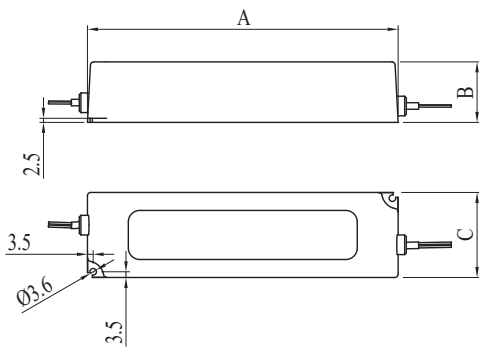

MOUNTING INSTRUCTIONS MONTAVIMO INSTRUKCIJOS / INSTRUCCIONES DE INSTALACION INSTRUCTIONS DE MONTAGE / MONTAGEANLEITUNGEN

Insert the lighting device inside the slot
Įdėkite apšvietimo įtaisą į angą/ LED dans la rainure / Die LED Leiste in die Nut einsetzen



Connect to a proper power supply
Prijunkite prie tinkamo maitinimo šaltinio/
Conectar a una alimentacion apropiada
Connecter à une alimentation appropriée / Den angemessenen Trafo





OPTICAL AND LIGHTING TECHNICAL INFORMATION

OPTINĖ IR APŠVIETIMO TECHNINĖ INFORMACIJA / CARACTERÍSTICAS ÓPTICAS Y LUMINOTECNICAS / CARACTÉRISTIQUES OPTIQUES ET ET DONNÉES D'ÉCLAIRAGE / OPTISCHE UND BELEUCHTUNGSTECHNISCHE MERKMALE

79 lm/W (1200 lm/m)

Luminous efficacy
Šviesos efektyvumas
Eficacia luminosa
Efficacité lumineuse
Lichtausbeute

120 led/m

Number of LEDs
Šviesos diodų skaičius
Nombre de led
Número de LEDs
Anzahl an LEDs

CRI > 80

Sp.our Rendering Index
Spalvų atgavos indeksas
Índice de reproducción cromática
Indice de rendu chromatique
Farbwiedergabeindex

L70(6K) > 248000 h

Service life
Tarnavimo laikas
Vida útil
Cycle de vie
Lebensdauer

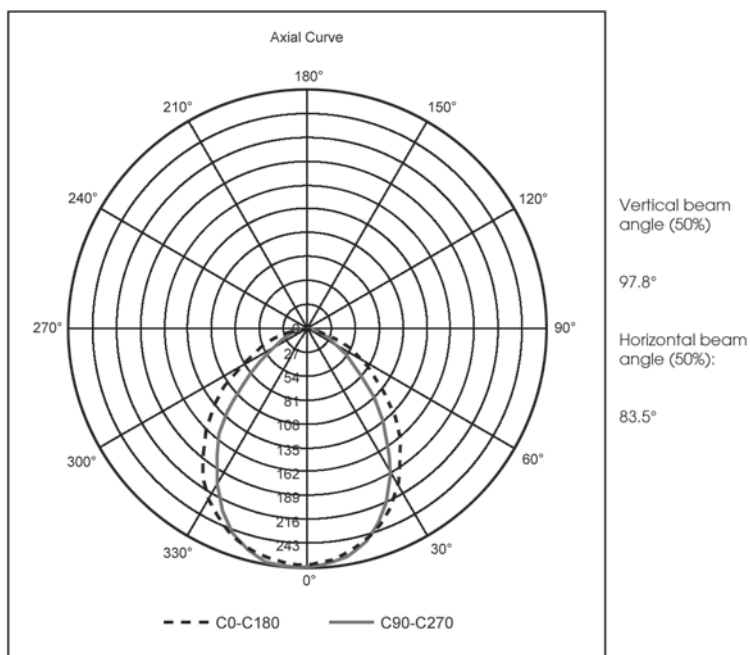

Photometry referred to a piece L=500
Fotometrija, susijusi su segmentu L=500

ELECTRICAL SPECIFICATIONS

ELEKTRINĖS CHARAKTERISTIKOS / CARACTERÍSTICAS ELÉCTRICAS / CARACTÉRISTIQUES ÉLECTRIQUES / ELEKTRISCHE

IP 55

Ingress Protection rating
Saugos klasė
Grado de protección
Indice de protection Schutzart

III

Protection class
Izoliacijos klasė Clase de aislamiento Classe d'isolation
Schutzklasse

MECHANICAL CHARACTERISTICS

MECHANINĖS CHARAKTERISTIKOS / CARACTERÍSTICAS MECÁNICAS / CARACTÉRISTIQUES MÉCANIQUES / MECHANISCHE

6060 T6

Extruded aluminium body, alloy
Ekstruzinio aliuminio korpusas, lydinys
Cuerpo de aluminio extruido, aleación
Corps en aluminium extrudé, alliage
Körper aus stranggepresstem Aluminium, Legierung

Extruded and sanitised PMMA

Covering
Dangtis
Cubierta
Couverture
Abdeckung



FLAT SURFACE LIGHTING DIAGRAMS

PLOKŠČIŲ PAVIRŠIŲ APŠVIETIMO SCHEMAS / DIAGRAMAS DE ILUMINACIÓN SOBRE UNA SUPERFICIE PLANA
GRAPHIQUES D'ÉCLAIRAGE SUR UNE SURFACE PLATE / BELEUCHTUNGSDIAGRAMM AUF EINER EBENEN FLÄCHE

1 m long LED lighting device set at the centre of a 1.5 m x 1.5 m square surface
 1 m ilgio LED apšvietimo įtaisas, sumontuotas 1,5 m x 1,5 m kvadratinio paviršiaus centre
 Luz LED de 1 m de longitud colocada en el centro de un cuadrado de 1,5 m x 1,5 m
 Lampe à LED de 1 m de longueur positionnée au centre d'un carré de 1,5 m x 1,5 m
 1 m lange, in der Mitte eines 1,5 m x 1,5 m großen Quadrats aufgestellte LED-Leiste

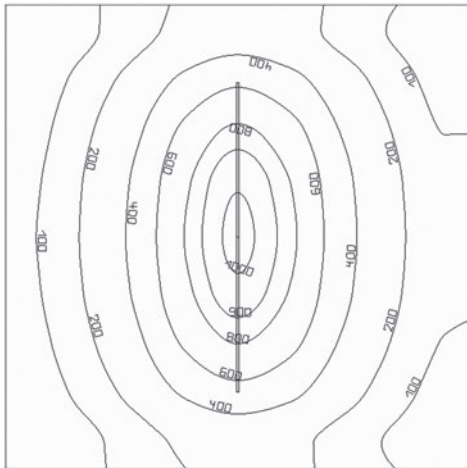

1500x1500x500 - 1000

0.50m

Distance from the illuminated surface
 Atstumas nuo apšviesto paviršiaus
 Distancia desde el plano iluminado Distance de
 la surface éclairée Abstand von der
 beleuchteten Fläche

Em = 337 lx

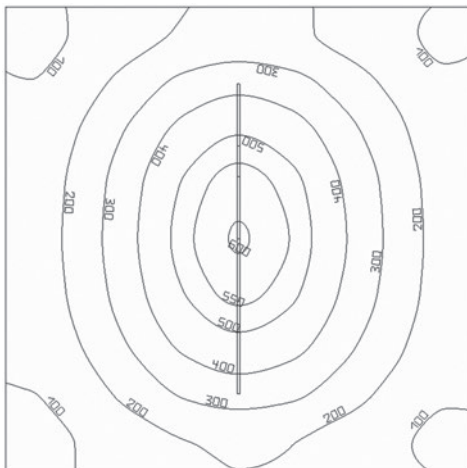

1500x1500x750 - 1000

0.75m

Distance from the illuminated surface
 Atstumas nuo apšviesto paviršiaus
 Distancia desde el plano iluminado Distance de
 la surface éclairée Abstand von der
 beleuchteten Fläche

Em = 272 lx

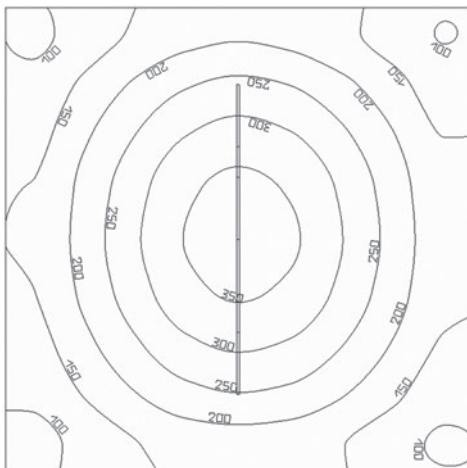

1500x1500x1000 - 1000

1m

Distance from the illuminated surface
 Atstumas nuo apšviesto paviršiaus
 Distancia desde el plano iluminado Distance de
 la surface éclairée Abstand von der
 beleuchteten Fläche

Em = 214 lx



GRĘŽIMO ŠABLONAS 25x84

BH
8
30

MASCHERA FORATURA
PLANTILLA DE TALADRADO
GABARIT DE PERÇAGE
BOHRMASKE

Kodas	Pastaba	g
084.818.013	Complete with screws - Komplekte su varžtais - Incluye tornillos - Doté de vis - Einschließlich Schrauben	70

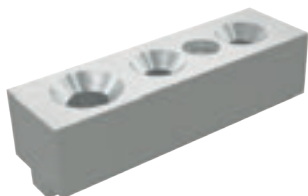

Aluminium
Alluminis
Aluminio
Aluminium
Aluminium

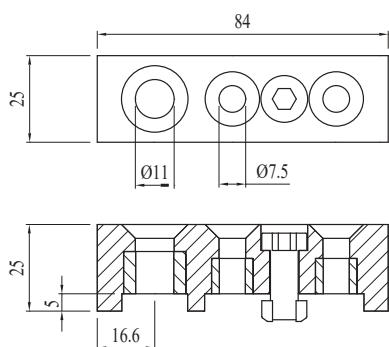

GRĘŽIMO ŠABLONAS 30x88

BH
10
40

BH
10
50

MASCHERA FORATURA
PLANTILLA DE TALADRADO
GABARIT DE PERÇAGE
BOHRMASKE

Kodas	Pastaba	g
084.818.011	Complete with screws - Komplekte su varžtais - Incluye tornillos - Doté de vis - Einschließlich Schrauben	85



Aluminium
Alluminio
Aluminio
Aluminium
Aluminium

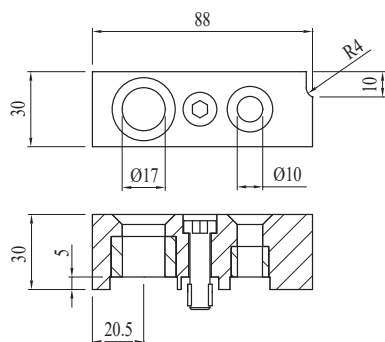



GREŽIMO ŠABLONAS 30x118

MASCHERA FORATURA
PLANTILLA DE TALADRADO
GABARIT DE PERÇAGE
BOHRMASKE



Kodas	Pastaba	g
084.818.012	Complete with screws - Komplekte su varžtais - Incluye tornillos - Doté de vis - Einschließlich Schrauben	85

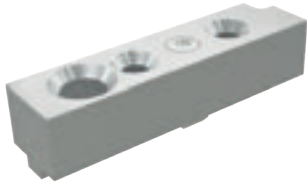

Aluminium
Alluminis
Aluminio
Aluminium
Aluminium

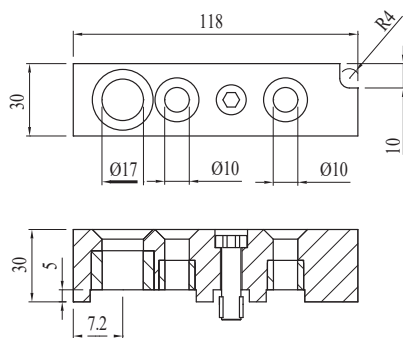

Ø5.5 MM GRAŽTAS

PUNTA Ø5,5
BROCA Ø5,5
FORET Ø 5,5
BOHREINSATZ Ø5,5

Kodas	Pastaba	g
084.818.005	Suitable for 6 mm slot profiles - Profiliams su 6 mm grioveliu - Apta para perfiles con ranura de 6 mm - Adaptée aux profilés rainure 6 - Geeignet für Profile mit Nut 6	20

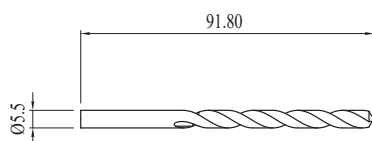



Ø 7.5 MM GRAŽTAS

PUNTA Ø7,5
 BROCA Ø7,5
 FORET Ø 7,5
 BOHREINSATZ Ø7,5

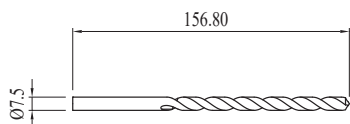

Kodas	Pastaba	g
084.818.006	Suitable for 8 mm slot profiles - Profiliams su 8 mm grioveliu- Apta para perfiles con ranura de 8 mm - Adaptée aux profilés rainure 8 - Geeignet für Profile mit Nut 8	53

Ø 7 MM GRAŽTAS

PUNTA Ø7
 BROCA Ø7
 FORET Ø 7
 BOHREINSATZ Ø7

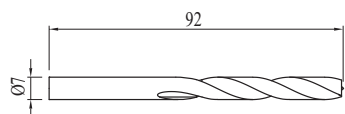

Kodas	Pastaba	g
084.818.007	Suitable for M5 bushings - Įvorėms M5 - Apta para casquillos M5 - Adaptée aux douilles M5 - Geeignet für Buchsen M5	50

**Ø 9,0 MM GRAŽTAS**

PUNTA Ø9
 BROCA Ø9
 FORET Ø 9
 BOHREINSATZ Ø9

Kodas	Pastaba	g
084.818.008	Suitable for M6 bushings - Įvorėms M6 - Apta para casquillos M6 - Adaptée aux douilles M6 - Geeignet für Buchsen M6	75

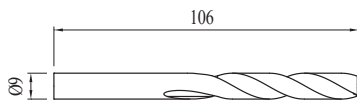
**Ø 11 MM GRAŽTAS**

PUNTA Ø11
 BROCA Ø11
 FORET Ø 11
 BOHREINSATZ Ø11

Kodas	Pastaba	g
084.818.009	Suitable for M8 bushings - Įvorėms M8 - Apta para casquillos M8 - Adaptée aux douilles M8 - Geeignet für Buchsen M8	95

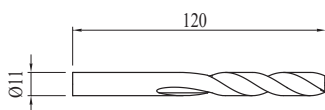

**Ø9 - Ø13.5 mm ĮGREŽIMO GRAŽTAS**

PUNTA PER LAMATURE
 BROCA PARA AVELLANADO
 FRAISE À LAMER
 BOHREINSATZ FÜR SENKUNGEN

Kodas	Pastaba	g
084.818.003	For Ø9 - Ø13.5 mm counterbore - Įgrežimui Ø9 - Ø13,5 - Para avellanados Ø9 - Ø13,5 - Pour lamages Ø 9 - Ø 13,5 - Für Senkungen Ø9 - Ø13,5	120

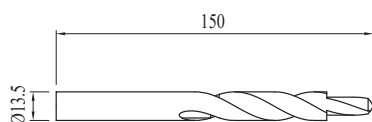
**ŠEŠIAKAMPIŲ RAKTŲ RINKINYS**

SET DI CHIAVI ESAGONALI
 SET DE LLAVES HEXAGONALES
 JEU DE CLÉS ALLEN SECHSKANTSCHLÜSSELSET

Kodas	Pastaba	g
084.818.010	Set of 2.5 - 6 mm wrenches - Kompletas raktų 2,5 - 6 - Set de llaves 2,5-6 - Jeu de clés 2,5 - 6 - Schlüss elset 2,5 - 6	700



**TVIRTAI SUJUNGIANTYS KLIJAI**

COLLA AD ALTA RESISTENZA PEGAMENTO DE ALTA
RESISTENCIA
COLLE À HAUTE RÉSISTANCE HOCHFESTER KLEBSTOFF



Kodas	Pastaba	g
084.818.004	High-strength adhesive for steel and aluminium - Didelio stiprumo klijai plienui ir aliuminiui nio - Pegamento de alta resistencia para acero y aluminio - Sp.le à haute résistance pour acier et aluminium - Hochfester Klebstoff für Stahl und Aluminium	70



DURYS SU SAUGOS JUNGIKLIU

PORTE CON INTERRUPTORE DI SICUREZZA
PUERTAS CON INTERRUPTOR DE SEGURIDAD
PORTES AVEC INTERRUPTEUR DE SÉCURITÉ
TUREN MIT SICHERHEITSSCHALTER

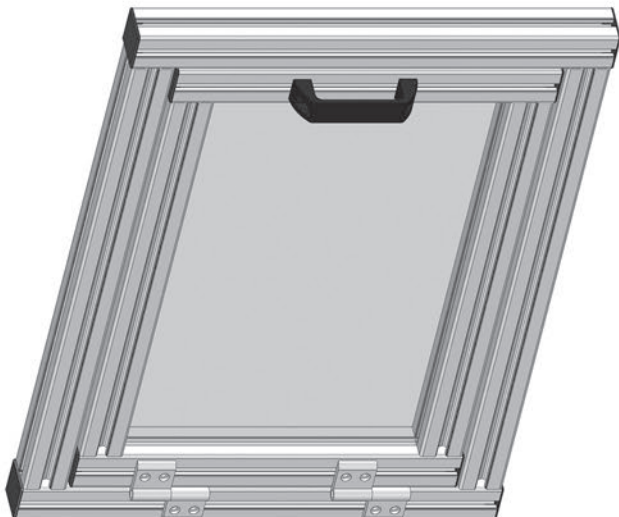
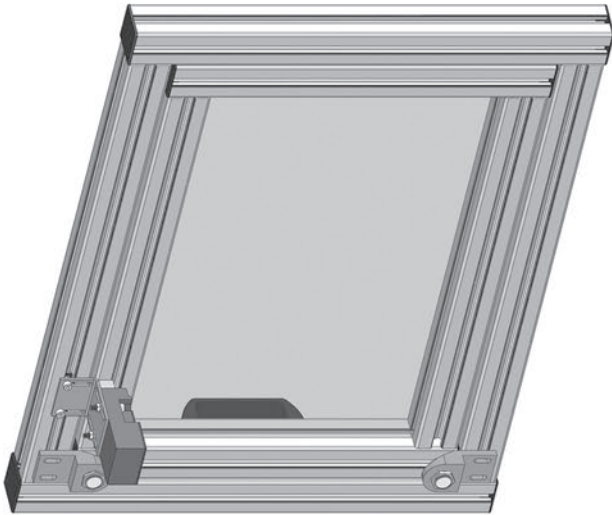

SPORTELO
LxH
L= A-7
H= B-10
P= L-90

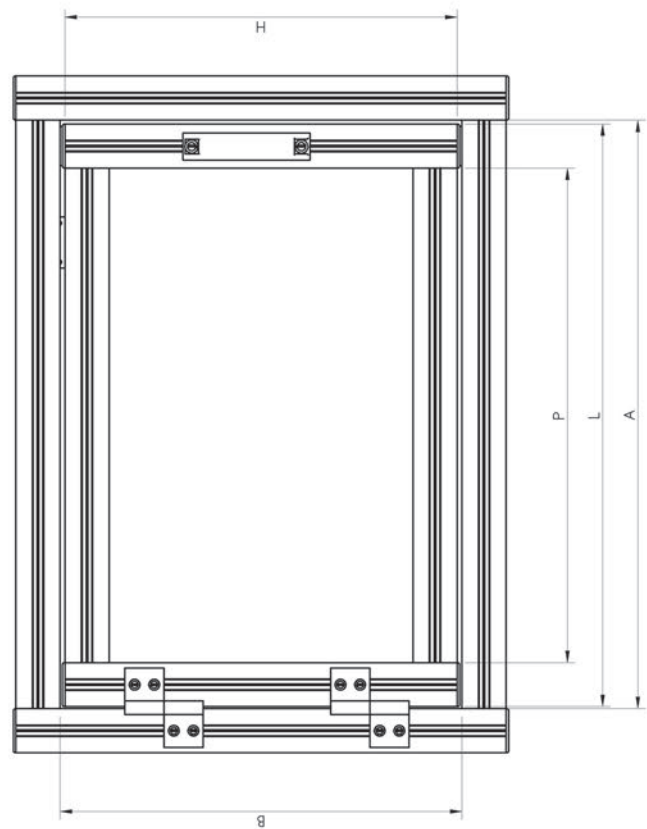



DURYS SU SAUGOS JUNGIKLIU

PORTE CON INTERRUOTORE DI SICUREZZA
 PUERTAS CON INTERRUPTOR DE SEGURIDAD
 PORTES AVEC INTERRUPTEUR DE SÉCURITÉ
 TÜREN MIT SICHERHEITSSCHALTER

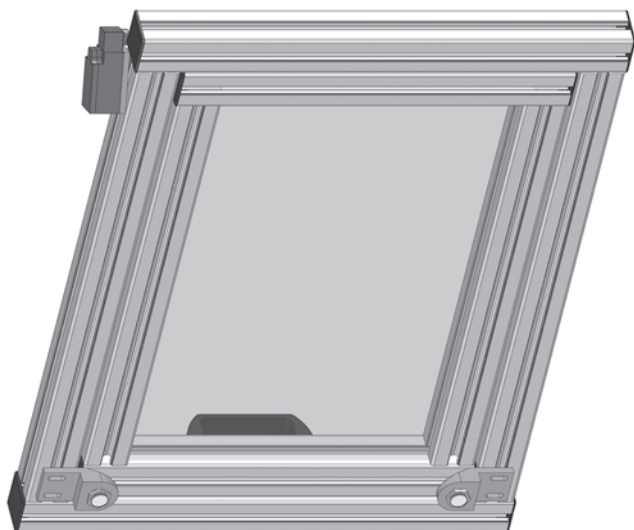

SPORTELO
LxH
L= A-7
H= B-10
P= L-90

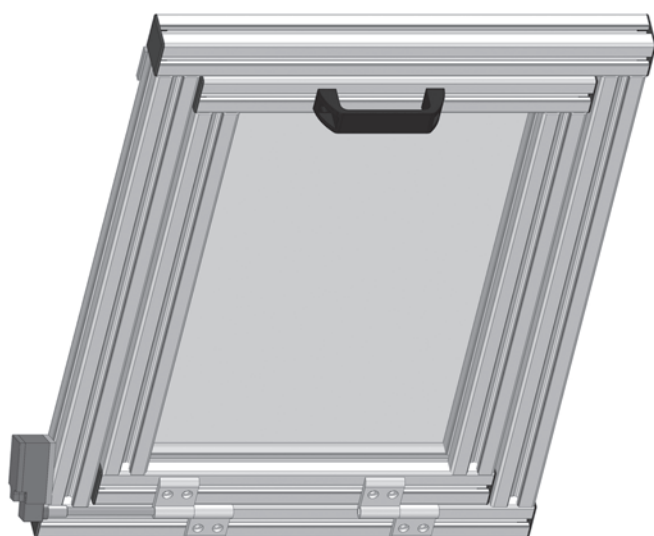
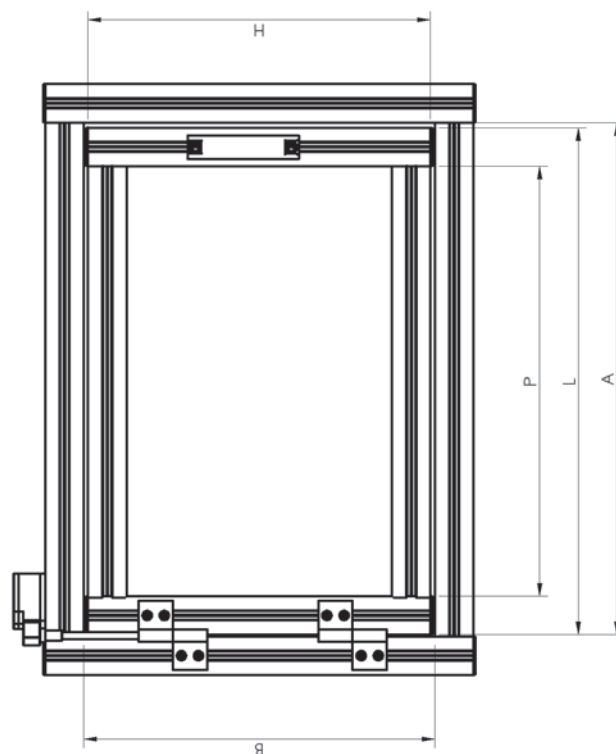



STUMDOMOS DURYS SU DAUGIAFUNKCIU PROFILIU

PORTE SCORREVOLI CON PROFILO MULTIUSO PUERTAS
CORREDIZAS CON PERFIL MULTIUSO PORTES
COULISSANTES AVEC PROFILÉ POL YVALENT
SCHIEBETUREN MIT MEHRZWECKPROFIL

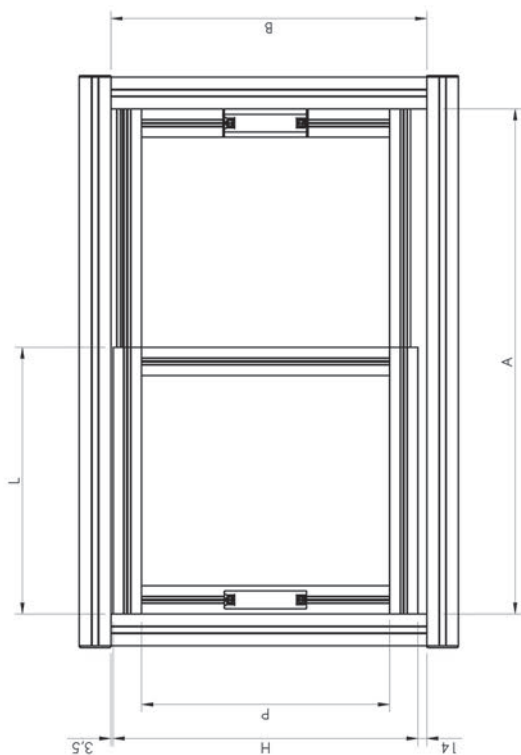

SPORTELO
LxH
L= (A/2) + 22,5
H= B-17,5
P= H-90

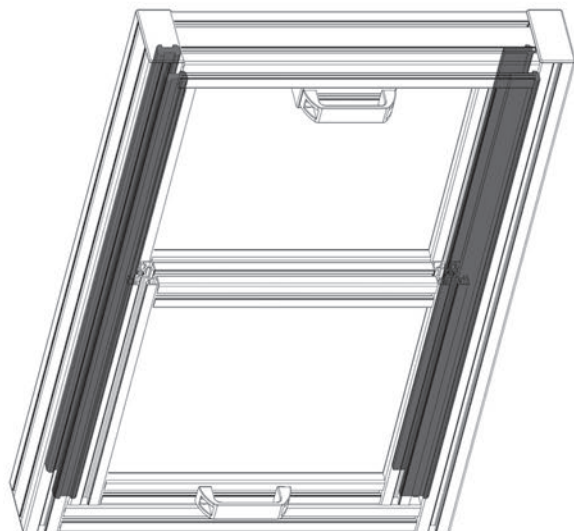



INDEX

TURINYS
ÍNDICE
INDEX
INDEX

KODAS	Psl.	KODAS	Psl.	KODAS	Psl.
008VEKA103	193	084.107.011	24	084.201.062	18
008VEKA111	193	084.107.012	27	084.201.062G	18
008VEKA115	193	084.109.001	51	084.201.063	25
013.100.030	223	084.109.002	51	084.201.063G	25
013.100.031	223	084.109.003	52	084.201.064	33
013.100.032	224	084.111.001	17	084.201.064G	33
013.100.033	224	084.111.002	18	084.201.065	33
013.506.008	213	084.111.004	17	084.201.065G	33
013.506.009	212	084.112.001	57	084.201.066	34
013.506.010A	212	084.112.002	58	084.201.066G	34
013.506.010A	213	084.113.001	33	084.201.067	43
013.506.010G	212	084.113.002	33	084.201.067G	43
013.506.010G	213	084.113.003	34	084.201.068	52
030LEX	191	084.201.038	39	084.201.068G	52
031LEX	191	084.201.038	39	084.201.069	57
032LEX	191	084.201.038	40	084.201.069G	57
034LEX	191	084.201.038	40	084.201.070	58
035LEX	191	084.201.038	41	084.201.070G	58
059.032.029	219	084.201.038G	39	084.201.071	41
062LEX	192	084.201.038G	39	084.201.071G	41
084.101.053	62	084.201.038G	40	084.201.074	46
084.101.054	62	084.201.038G	40	084.201.074G	46
084.101.055	64	084.201.038G	41	084.201.075	17
084.101.056	63	084.201.039	42	084.201.075G	17
084.101.056	64	084.201.039	43	084.201.079	63
084.101.078	63	084.201.039G	42	084.201.096	61
084.101.079	63	084.201.039G	43	084.201.097	61
084.101.092	61	084.201.040	44	084.201.099	64
084.101.093	61	084.201.040	44	084.201.101	63
084.101.097	61	084.201.040	45	084.201.102	62
084.101.098	61	084.201.040	45	084.201.103	65
084.101.098	62	084.201.040	46	084.202.002	88
084.101.099	64	084.201.040G	44	084.202.002N	88
084.101.100	64	084.201.040G	44	084.202.005	88
084.101.101	63	084.201.040G	45	084.202.005N	88
084.101.102	62	084.201.040G	45	084.202.006	89
084.101.104	65	084.201.040G	46	084.202.007	90
084.101.105	65	084.201.041	23	084.202.008	90
084.104.003	57	084.201.041	23	084.202.009	89
084.105.004	39	084.201.041	24	084.203.010	70
084.105.005	44	084.201.041	24	084.203.010N	70
084.105.006	42	084.201.041	25	084.203.023	69
084.105.007	42	084.201.041G	23	084.203.024	69
084.105.008	43	084.201.041G	23	084.203.024	189
084.105.009	45	084.201.041G	24	084.203.026	70
084.105.010	39	084.201.041G	24	084.203.027	70
084.105.011	40	084.201.041G	25	084.206.001	125
084.105.012	41	084.201.042	26	084.206.001	125
084.105.013	46	084.201.042	26	084.206.001G	125
084.105.014	44	084.201.042G	26	084.206.001G	125
084.105.015	40	084.201.042G	26	084.206.002	126
084.105.016	45	084.201.052	42	084.206.002	126
084.105.017	46	084.201.052G	42	084.206.002G	126
084.105.018	41	084.201.053	62	084.206.002G	126
084.105.019	43	084.201.055	51	084.206.003	132
084.105.020	47	084.201.055G	51	084.206.003	133
084.107.002	23	084.201.056	51	084.206.003	133
084.107.003	26	084.201.056G	51	084.206.003	134
084.107.004	27	084.201.057	27	084.206.003G	132
084.107.005	25	084.201.057	28	084.206.003G	133
084.107.006	23	084.201.057G	27	084.206.003G	133
084.107.007	28	084.201.057G	28	084.206.003G	134
084.107.008	24	084.201.059	64	084.206.005	136
084.107.009	25	084.201.061	17	084.206.005	136
084.107.010	26	084.201.061G	17	084.206.005	137

KODAS	Psl.	KODAS	Psl.	KODAS	Psl.
084.206.005	137	084.302.022	77	084.305.024T	131
084.206.006	138	084.302.023	77	084.305.026	133
084.206.006	138	084.302.024	77	084.305.026T	134
084.206.007	122	084.302.025	78	084.305.028	137
084.206.007G	122	084.302.026	78	084.305.028T	137
084.206.008	123	084.302.027	78	084.305.030	138
084.206.008	123	084.302.028	78	084.305.032	122
084.206.008G	123	084.302.029	79	084.305.033	136
084.206.008G	123	084.302.036	83	084.305.033T	136
084.206.009	130	084.302.043	80	084.305.034	138
084.206.009	130	084.302.044	80	084.305.036	123
084.206.010	140	084.302.045	80	084.305.037	142
084.206.010	140	084.302.046	80	084.305.038	142
084.206.011	135	084.302.061	77	084.305.039	143
084.206.011	135	084.302.062	78	084.305.040	130
084.206.012	141	084.302.063	78	084.305.040T	130
084.206.012	141	084.302.064	78	084.305.041	125
084.207.003	158	084.302.065	79	084.305.042	139
084.207.003	158	084.302.066	79	084.305.043	139
084.207.003	160	084.302.067	79	084.305.044	127
084.207.004	163	084.302.069	80	084.305.045	135
084.301.001	71	084.302.070	80	084.305.045T	135
084.301.002	71	084.302.071	80	084.305.047	140
084.301.003	71	084.302.072	80	084.305.047T	140
084.301.004	71	084.302.081	82	084.305.049	141
084.301.005	71	084.302.082	82	084.305.049T	141
084.301.006	71	084.302.083	82	084.305.050	120
084.301.007	71	084.302.084	82	084.305.051	120
084.301.008	71	084.302.095	79	084.305.052	121
084.301.009	71	084.302.096	79	084.305.054	129
084.301.010	71	084.302.097	79	084.305.056	144
084.301.011	71	084.302.098	79	084.305.058	129
084.301.012	71	084.302.099	81	084.305.059	126
084.301.013	71	084.302.100	81	084.305.060	127
084.301.018	75	084.302.101	81	084.306.008	92
084.301.019	75	084.302.102	81	084.306.009	92
084.301.020	75	084.302.103	81	084.306.013	94
084.301.021	75	084.302.115	82	084.306.014	91
084.301.024	73	084.302.116	82	084.306.015	91
084.301.025	72	084.302.117	82	084.306.017	93
084.301.026	72	084.302.118	82	084.306.018	93
084.301.027	72	084.302.119	81	084.307.024	102
084.301.028	72	084.302.120	81	084.307.025	102
084.301.029	72	084.302.121	81	084.307.031	107
084.301.030	72	084.302.122	81	084.307.032	108
084.301.031	72	084.302.127	83	084.307.036	106
084.301.032	72	084.302.128	83	084.307.037	101
084.301.033	72	084.303.004	86	084.307.039	94
084.301.034	72	084.303.007	86	084.307.040	95
084.301.035	71	084.303.008	87	084.307.041	95
084.301.036	71	084.305.001	125	084.307.042	96
084.301.037	74	084.305.002	126	084.307.043	96
084.301.038	71	084.305.003	132	084.307.044	97
084.301.039	73	084.305.003T	133	084.307.045	97
084.301.040	73	084.305.006	122	084.307.046	98
084.301.041	74	084.305.007	124	084.307.047	98
084.301.042	74	084.305.008	124	084.307.048	99
084.301.043	74	084.305.009	128	084.307.049	99
084.301.044	74	084.305.009T	128	084.307.050	100
084.301.045	75	084.305.010	123	084.307.051	101
084.301.046	76	084.305.016	143	084.307.052	106
084.301.047	76	084.305.017	144	084.307.053	107
084.301.054	71	084.305.021	134	084.308.001	117
084.301.079	73	084.305.022	132	084.308.002	118
084.302.021	77	084.305.024	131	084.308.003	117

KODAS	PsL.	KODAS	PsL.	KODAS	PsL.
084.308.004	118	084.405.019	145	084.503.003	197
084.308.006	119	084.405.020	145	084.504.001	212
084.308.007	119	084.405.021	147	084.504.002	212
084.310.013	112	084.405.022	147	084.504.003	212
084.310.014	113	084.405.023	145	084.506.003	215
084.310.014G	113	084.405.024	147	084.506.005A	214
084.310.015	113	084.405.025	147	084.506.005B	214
084.310.015G	113	084.405.026	147	084.506.005N	214
084.310.020	109	084.405.027	145	084.506.006	218
084.310.021	109	084.406.001	148	084.506.006G	218
084.310.022	110	084.407.003	178	084.506.006G	218
084.310.023	110	084.407.010	179	084.506.006PA	219
084.310.023G	110	084.408.001	149	084.506.006R	220
084.310.024	111	084.408.002	153	084.506.007G	216
084.310.024G	111	084.408.003	149	084.506.007GR	217
084.310.027	111	084.409.001	152	084.506.007N	215
084.310.029	112	084.409.002	160	084.506.007NR	216
084.311.011	116	084.409.003	160	084.506.008	214
084.311.012	116	084.409.004	158	084.506.009A	220
084.311.016	114	084.409.005	158	084.506.009B	221
084.311.019	115	084.409.006	150	084.506.009PA	221
084.311.020	115	084.409.007	150	084.506.011	213
084.311.021	114	084.409.008	151	084.507.001	180
084.312.003	84	084.409.009	162	084.509.001	180
084.312.004	84	084.409.010	162	084.509.002	181
084.312.005	85	084.409.011	161	084.509.003	181
084.312.006	85	084.409.012	163	084.510.001	182
084.312.007	85	084.409.013	161	084.510.002	182
084.312.014	108	084.409.014	159	084.510.003	182
084.401.001	154	084.409.015	151	084.510.004	182
084.401.002	154	084.409.016	152	084.510.009	183
084.401.003	154	084.409.018	159	084.510.010	183
084.401.004	154	084.410.003	157	084.510.011	183
084.402.001	155	084.410.006	157	084.510.012	183
084.402.002	155	084.500.003	198	084.510.013	230
084.402.003	155	084.500.006	200	084.510.017	184
084.402.004	155	084.500.009	201	084.510.018	231
084.402.005	155	084.500.010	204	084.510.019	231
084.402.006	155	084.500.011	204	084.510.020	184
084.402.008	155	084.500.012	203	084.510.021	232
084.403.001	156	084.500.015	199	084.512.003	188
084.403.002	156	084.500.016	198	084.512.003	188
084.403.003	156	084.500.017	200	084.512.004	188
084.403.004	156	084.500.018	199	084.512.006	188
084.404.001	172	084.500.020	202	084.512.006G	188
084.404.002	175	084.500.020	202	084.512.006T	188
084.404.003	173	084.500.021	203	084.512.010	190
084.404.004	175	084.500.023	201	084.512.030	189
084.404.005	176	084.501.008	207	084.512.030G	189
084.404.006	172	084.501.009	209	084.512.056	188
084.404.007	174	084.501.010	210	084.512.056G	188
084.404.008	173	084.501.011	207	084.514.012	187
084.404.009	176	084.501.013	208	084.514.013	186
084.405.001	145	084.501.014	209	084.514.014	186
084.405.004	145	084.501.015	210	084.514.016	187
084.405.005	145	084.501.016	211	084.517.001	222
084.405.006	147	084.501.017	206	084.518.002	222
084.405.007	145	084.501.019	205	084.519.001	223
084.405.010	145	084.501.020	205	084.519.002	224
084.405.011	145	084.501.021	208	084.519.003	185
084.405.013	145	084.502.003	196	084.519.004	185
084.405.015	145	084.502.005	196	084.519.006	226
084.405.016	145	084.502.006	195	084.519.007	226
084.405.017	145	084.503.001	195	084.519.008	225
084.405.018	145	084.503.002	197		

KODAS	Psl.	KODAS	Psl.	KODAS	Psl.
084.522.001	227	135.401.001	166		
084.522.002	227	135.401.002	166		
084.522.003	228	135.401.101	168		
084.523.001	228	135.401.102	168		
084.523.002	230	135.401.201.1000	169	135.401.202	
084.523.003	229		169		
084.524.001	229	511.011.000B	177		
084.525.001	225	511.011.000G	177		
084.527.001	234	511.011.000R	177		
084.527.002	234	511.011.000V	177		
084.527.003	234	670.001.000	194		
084.527.004	234	700.013.4000.0250	243		
084.527.005	234	700.013.4000.0250B	243		
084.527.006	234	700.013.4000.0250G	243		
084.527.007	234	700.013.4000.0250R	243		
084.527.008	234	700.013.4000.0500	243		
084.527.009	234	700.013.4000.0500B	243		
084.527.010	234	700.013.4000.0500G	243		
084.527.011	234	700.013.4000.0500R	243		
084.527.012	234	700.013.4000.1000	243		
084.527.013	234	700.013.4000.1990	243		
084.527.014	234	700.013.4000.2990	243		
084.528.001	235	700.015.4000.0250	243		
084.528.002	235	700.015.4000.0250B	243		
084.528.003	236	700.015.4000.0250G	243		
084.528.004	236	700.015.4000.0250R	243		
084.531.001	239	700.015.4000.0500	243		
084.533.002	240	700.015.4000.0500B	243		
084.535.004	232	700.015.4000.0500G	243		
084.535.005	233	700.015.4000.0500R	243		
084.535.006	233	700.015.4000.1000	243		
084.536.001	146	700.015.4000.1990	243		
084.538.001	191	700.015.4000.2990	243		
084.538.002	191	700.024.020	245		
084.601.001	237	700.024.060	245		
084.601.002	237	800.019.449	244		
084.601.003	238	5004A/3170	188		
084.602.001	238	DILITE3	192		
084.603.001	239	RETE 11x66	194		
084.604.001	241	RETE 11x66 INOX	194		
084.604.002	241	RETE 40X40X4	194		
084.604.003	242	RETE TEC 1003	194		
084.608.001	240	STR3MM	193		
084.710.001	104	STR4MM	193		
084.710.002	103	STR5MM	193		
084.710.003	104				
084.710.004	103				
084.710.006N	105				
084.710.007N	105				
084.710.008N	105				
084.710.009N	105				
084.818.003	252				
084.818.004	253				
084.818.005	249				
084.818.006	250				
084.818.007	250				
084.818.008	251				
084.818.009	251				
084.818.010	252				
084.818.011	248				
084.818.012	249				
084.818.013	248				
135.070.400.2	164				
135.070.660.3	165				
135.301.007	170				





Progetto grafico e impaginazione Alusic, Mondovì (CN) Finito
di stampare nel mese di marzo 2025 presso tipografia San
Martino, San Martino in Rio (RE)

BH LINE
ED.17 UPD.05

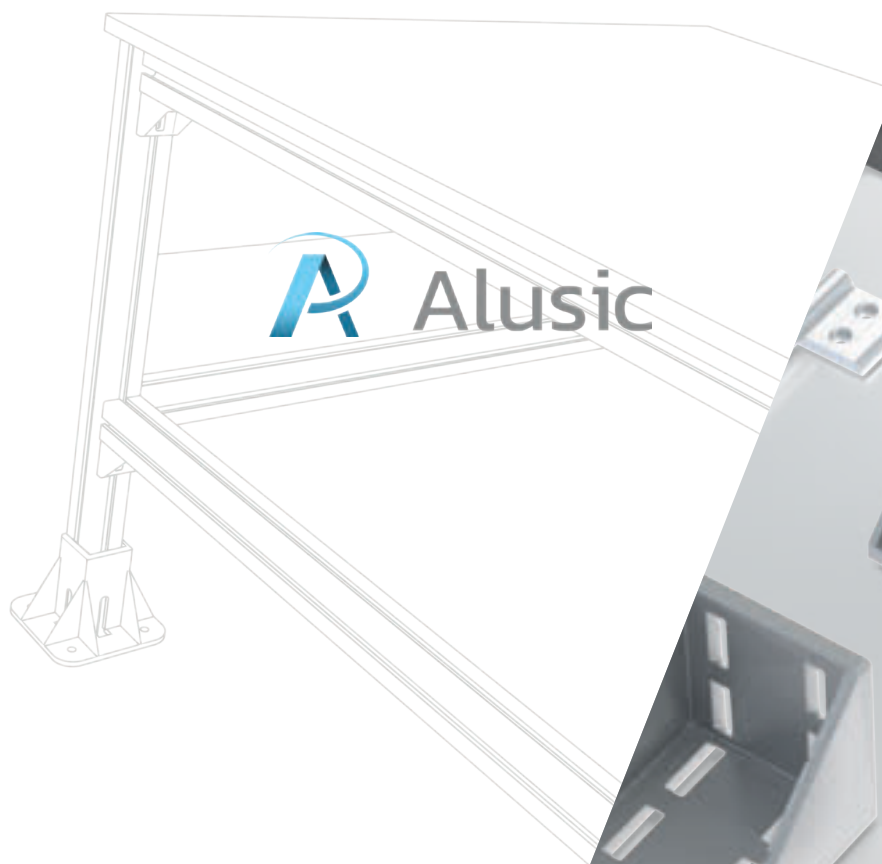

ALUSIC S.p.A.

VIA BOLOGNA, 10/D

12084 MONDOVÌ (CN) - ITALY

TEL.: (+39) 0174.55.29.49 - (+39) 0174.47.780

MAIL: contact@alusic.com www.alusic.com

copyright - 10/2025